

# BRUSHBULL™ ROTARY CUTTER

BB48.30

BB60.30

BB72.30

BB72.40

BB84.40

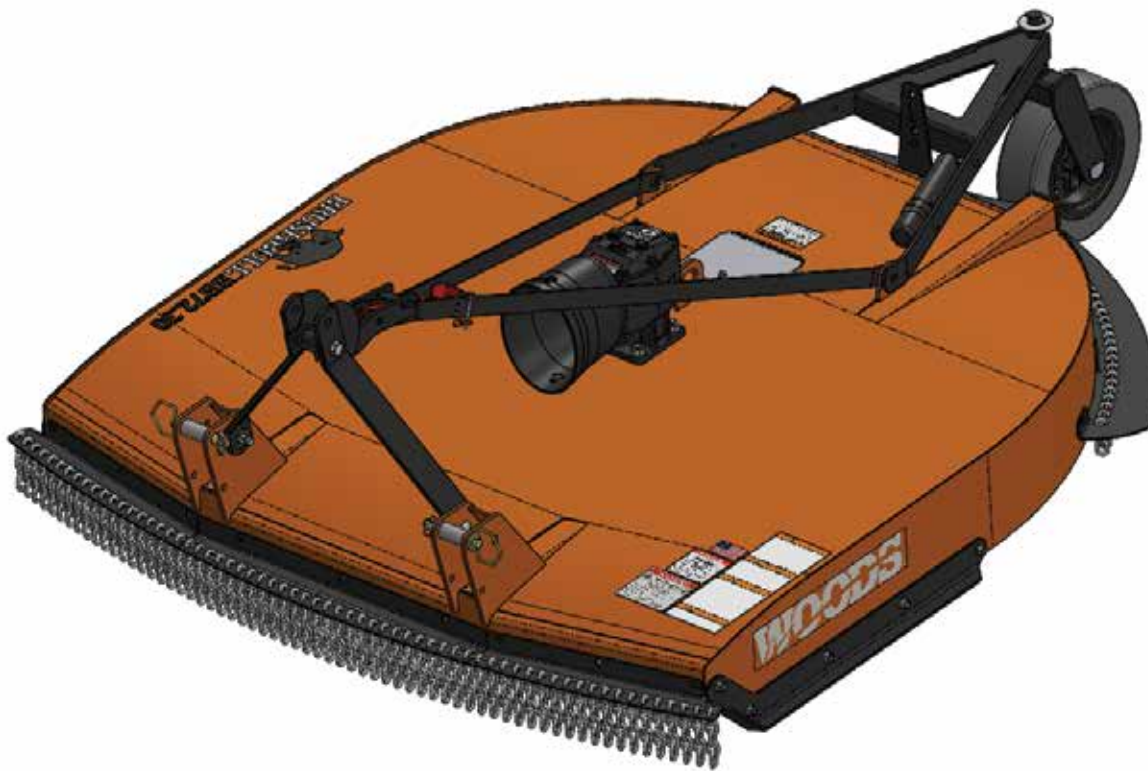

**MAN1289**  
(Rev 04/30/2024)

**WOODS®**

OPERATOR'S MANUAL

## TO THE DEALER:

Assembly and proper installation of this product is the responsibility of the Woods® dealer. Read manual instructions and safety rules. Make sure all items on the Dealer's Pre-Delivery and Delivery Checklists in the Operator's Manual are completed before releasing equipment to the owner.

**The dealer must complete the online Product Registration form at the Woods Dealer Website** which certifies that all Dealer Checklist items have been completed. Dealers can register all Woods product at [dealer.WoodsEquipment.com](http://dealer.WoodsEquipment.com) under Product Registration.

**Failure to register the product does not diminish customer's warranty rights.**

## TO THE OWNER:

Read this manual before operating your Woods equipment. The information presented will prepare you to do a better and safer job. Keep this manual handy for ready reference. Require all operators to read this manual carefully and become acquainted with all adjustment and operating procedures before attempting to operate. Replacement manuals can be obtained from your dealer. To obtain complete warranty details, visit [WoodsEquipment.com/warranty](http://WoodsEquipment.com/warranty). You may also request a hard copy by calling 1-800-319-6637 or mail your request to: Woods Equipment Company, Attn: Warranty Dept. 2606 South Illinois Route 2, Oregon, IL 61061. To locate your nearest dealer, check the Dealer Locator at [www.WoodsEquipment.com](http://www.WoodsEquipment.com), or in the United States and Canada call 1-800-319-6637.

The equipment you have purchased has been carefully engineered and manufactured to provide dependable and satisfactory use. Like all mechanical products, it will require cleaning and upkeep. Lubricate the unit as specified. Observe all safety information in this manual and safety decals on the equipment.

For service, your authorized Woods dealer has trained mechanics, genuine Woods service parts, and the necessary tools and equipment to handle all your needs.

Use only genuine Woods service parts. Substitute parts will void the warranty and may not meet standards required for safe and satisfactory operation. Record the model number and serial number of your equipment in the spaces provided:

**Model:** \_\_\_\_\_ **Date of Purchase:** \_\_\_\_\_

**Serial Number:** (see Safety Decal section for location) \_\_\_\_\_

Provide this information to your dealer to obtain correct repair parts.

Throughout this manual, the term **NOTICE** is used to indicate that failure to observe can cause damage to equipment. The terms **CAUTION**, **WARNING**, and **DANGER** are used in conjunction with the Safety-Alert Symbol (a triangle with an exclamation mark) to indicate the degree of hazard for items of personal safety.



This is the safety alert symbol. It is used to alert you to potential physical injury hazards. Obey all safety messages that follow this symbol to avoid possible injury or death.



Indicates a hazardous situation that, if not avoided, will result in death or serious injury.



Indicates a hazardous situation that, if not avoided, could result in death or serious injury.



Indicates a hazardous situation that, if not avoided, could result in minor or moderate injury.

**IMPORTANT  
or NOTICE**

Is used to address practices not related to physical injury.

**NOTE**

Indicates helpful information.

## 2 Introduction

MAN1289  
(04/30/2024)

# TABLE OF CONTENTS

<b>INTRODUCTION</b> . . . . .	<b>2</b>
SPECIFICATIONS . . . . .	4
GENERAL INFORMATION . . . . .	4
<b>SAFETY</b> . . . . .	<b>5</b>
MOWER SAFETY VIDEO . . . . .	5
SAFETY RULES . . . . .	7
TRAINING . . . . .	7
PREPARATION . . . . .	7
OPERATION . . . . .	8
MAINTENANCE . . . . .	8
TRANSPORTATION . . . . .	9
STORAGE . . . . .	9
SAFETY & INSTRUCTIONAL DECALS . . . . .	10
<b>OPERATION</b> . . . . .	<b>12</b>
OPERATION . . . . .	12
TRACTOR STABILITY . . . . .	12
ATTACHING CUTTER TO TRACTOR - BBXX.30 . . . . .	12
ATTACHING CUTTER TO TRACTOR - BBXX.40 . . . . .	13
DRIVELINE ATTACHMENT . . . . .	13
INSTALLATION AND REMOVAL OF DRIVELINE (TRACTOR PTO) . . . . .	14
SHORTENING DRIVELINE . . . . .	14
DRIVELINE INTERFERENCE CHECK . . . . .	15
CUTTING HEIGHT ADJUSTMENT . . . . .	15
SHREDDING MATERIAL HEIGHT ADJUSTMENT . . . . .	16
CHECK CHAIN ADJUSTMENT (OPTIONAL) . . . . .	16
OPERATING TECHNIQUE . . . . .	16
TRANSPORTING . . . . .	17
STORAGE . . . . .	17
PRE-OPERATION CHECKLIST . . . . .	17
<b>OWNER SERVICE</b> . . . . .	<b>18</b>
OWNER SERVICE . . . . .	18
BLOCKING METHOD . . . . .	18
LUBRICATION INFORMATION . . . . .	18
BLADE SERVICING . . . . .	19
SLIP CLUTCH ADJUSTMENT . . . . .	20
SHIELDING REPAIR . . . . .	21
CLEANING CUTTER . . . . .	21
<b>TROUBLESHOOTING</b> . . . . .	<b>22</b>
<b>DEALER SERVICE</b> . . . . .	<b>23</b>
DEALER SERVICE . . . . .	23
GEARBOX MAINTENANCE . . . . .	23
GEARBOX REPAIR (BBXX.30) . . . . .	24
SEAL REPAIR (BBXX.30) . . . . .	24
GEARBOX REPAIR (BBXX.40) . . . . .	26
SEAL REPAIR (BBXX.40) . . . . .	26
CROSSBAR REMOVAL . . . . .	28
CROSSBAR INSTALLATION . . . . .	29
UNIVERSAL JOINT REPAIR . . . . .	29
<b>ASSEMBLY</b> . . . . .	<b>31</b>
ASSEMBLY . . . . .	31
DEALER SET-UP INSTRUCTIONS . . . . .	31
DISASSEMBLE SHIPPING UNIT . . . . .	31
ASSEMBLE CUTTER . . . . .	32
INSTALL DRIVELINE . . . . .	32
INSTALL SAFETY SHIELDING . . . . .	33
INSTALL DUAL TAILWHEEL . . . . .	34
INSTALL CHECK CHAIN (OPTIONAL) . . . . .	34
<b>DEALER CHECKLISTS</b> . . . . .	<b>35</b>
<b>PARTS INDEX</b> . . . . .	<b>37</b>
<b>APPENDIX</b> . . . . .	<b>53</b>
BOLT TORQUE CHART . . . . .	53
BOLT SIZE CHART & ABBREVIATIONS . . . . .	54
<b>INDEX</b> . . . . .	<b>55</b>



This Operator's Manual should be regarded as part of the machine. Suppliers of both new and second-hand machines must make sure that this manual is provided with the machine.

# SPECIFICATIONS

	BB48.30	BB60.30	BB72.30	BB72.40	BB84.40
Cutting Width	48"	60"	72"	72"	84"
Overall Width	55"	67"	79"	79"	91"
Maximum Overall Length	86"	99"	111"	111"	124"
Weight (Approximate w/ chain shield)	635 lbs	728 lbs	882 lbs	955 lbs	1132 lbs
Cutting Height	1" - 9"		2" - 12"		
Blade Spindle	1				
Number of Blades	2				
Blades	Heat Treated Alloy Steel				
Blade Rotation	CCW				
Blade Tip Speed (feet per minute)	13,000	14,335	14,963	15,268	15,086
Gearbox Ratio	1:1.92	1:1.69	1:1.47	1:1.50	1:1.26
Gearbox Oil Type	80-90W EP Gear Lube				
Gearbox Oil Capacity	1.5 qt	1.5 qt	1.5 qt	1.9 qt.	1.9 qt
Recommended Tractor HP	15 - 50	25 - 50	30 - 75	35 - 90	35 - 90
Tractor PTO RPM	540				
3-Point Hitch Category	1		1 & 2		
Universal Drive Category	3		4		
Operating Temperature Range	-20° to 110° F				
Side Frame Thickness	10 GA				
Tailwheel	4" x 16"		5" x 16"		

## GENERAL INFORMATION

### WARNING

- Some illustrations in this manual show the mower with safety shields removed to provide a better view. The mower should never be operated with any safety shielding removed.

The purpose of this manual is to assist you in operating and maintaining your cutter. Read it carefully. It furnishes information and instructions that will help you achieve years of dependable performance. These instructions have been compiled from extensive field experience and engineering data. Some information may be general in nature due to unknown and varying operating conditions. However, through experience

and these instructions, you should be able to develop procedures suitable to your particular situation.

The illustrations and data used in this manual were current at the time of printing but, due to possible inline production changes, your machine may vary slightly in detail. We reserve the right to redesign and change the machines as may be necessary without notification.

Throughout this manual, references are made to right and left directions. These are determined by standing behind the equipment facing the direction of forward travel. Blade rotation is clockwise (left wing) and counterclockwise (right wing and center section) as viewed from the top of the cutter.



### ¡LEA EL INSTRUCTIVO!

Si no lee Ingles, pida ayuda a alguien que si lo lee para que le traduzca las medidas de seguridad.

### NOTICE:

If you would like to receive a free Spanish language translation of the Safety Rules section of this manual, plus a set of Spanish language safety decals, please contact your local Woods dealer.

### AVISO:

Si desea recibir una traducción al español gratuita de la sección de Reglas de seguridad de este manual y un juego de etiquetas de seguridad en español, por favor comuníquese con su concesionario local de Woods.

## 4 Introduction

MAN1289  
(04/30/2024)

**BE SAFE!**

**BE ALERT!**

**BE ALIVE!**

**BE TRAINED**

**Before Operating Mowers!**



*Safety Training  
Does Make a Difference.*

---

## **Watch a Mower Safety Video Online**

The AEM (Association of Equipment Manufacturers) offers a safety training video, *Industrial and Agricultural Mower Safety Practices*. The 22-minute video can be viewed online for free at TheAEMStore,

<https://youtu.be/uEWXsDqhDq0>

It reinforces the proper procedures to follow while operating your mowing equipment. The video does not replace the information contained in the Operator's Manual, so please review this manual thoroughly before operating your new mowing equipment.

## **Also, available from the Association of Equipment Manufacturers:**

A large variety of training materials (ideal for groups) are available for a nominal charge from AEM. Following is a partial list:

- **Training Package for Rotary Mowers/Cutters-English**  
Contains: DVD & VHS (English)
  - Guidebook for Rotary Mowers/Cutters (English)
  - AEM Industrial/Agricultural Mower Safety Manual (English)
  - AEM Agricultural Tractor Safety Manual (English)
- **Training Package for Rotary Mowers/Cutters-English/Spanish**  
Contains: DVD & VHS (English/Spanish)
  - Guidebook for Rotary Mowers/Cutters (English/Spanish)
  - AEM Industrial/Agricultural Mower Safety Manual (English/Spanish)
  - AEM Agricultural Tractor Safety Manual (English/Spanish)

AEM training packages are available through:

AEM at: [www.aem.org](http://www.aem.org)

or

Universal Lithographers, Inc.

Email: [aem@ulilitho.com](mailto:aem@ulilitho.com)

800-369-2310 tel

866-541-1668 fax

# SAFETY RULES



**ATTENTION! BECOME ALERT! YOUR SAFETY IS INVOLVED!**



Safety is a primary concern in the design and manufacture of our products. Unfortunately, our efforts to provide safe equipment can be wiped out by an operator's single careless act.

In addition to the design and configuration of equipment, hazard control and accident prevention are dependent upon the awareness, concern, judgement, and proper training of personnel involved in the operation, transport, maintenance, and storage of equipment.

It has been said, "The best safety device is an informed, careful operator." We ask you to be that kind of operator.

## TRAINING

- **Safety instructions are important! Read all attachment and power unit manuals; follow all safety rules and safety decal information.** (Replacement manuals and safety decals are available from your dealer. To locate your nearest dealer, check the Dealer Locator at [www.WoodsEquipment.com](http://www.WoodsEquipment.com), or in the United States and Canada call 1-800-319-6637.) Failure to follow instructions or safety rules can result in serious injury or death.
- **If you do not understand any part of this manual and need assistance, see your dealer.**
- **Know your controls and how to stop engine and attachment quickly in an emergency.**
- **Operators must be instructed in and be capable of the safe operation of the equipment, its attachments, and all controls. Do not allow anyone to operate this equipment without proper instructions.**
- **Never allow children or untrained persons to operate equipment.**

## PREPARATION

- **Check that all hardware is properly installed. Always tighten to torque chart specifications unless instructed otherwise in this manual.**
- **Always wear relatively tight and belted clothing to avoid getting caught in moving parts. Wear sturdy, rough-soled work shoes and protective equipment for eyes, hair, hands, hearing, and head; and respirator or filter mask where appropriate.**
- **Make sure attachment is properly secured, adjusted, and in good operating condition.**

- **Make sure spring-activated locking pin or collar slides freely and is seated firmly in tractor PTO spline groove.**
- **Connect PTO driveline directly to power unit PTO shaft. Never use adapter sleeves or adapter shafts. Adapters can cause driveline failures due to incorrect spline or incorrect operating length and can result in personal injury or death.**
- **Make sure driveline guard tether chains are attached to the tractor and equipment as shown in the pamphlet that accompanies the driveline. Replace if damaged or broken. Check that driveline guards rotate freely on driveline before putting equipment into service.**
- **Before starting power unit, check all equipment driveline guards for damage. Replace any damaged guards. Make sure all guards rotate freely on all drivelines. If guards do not rotate freely on drive-lines, repair and replace bearings before putting equipment into service.**
- **Power unit must be equipped with ROPS or ROPS cab and seat belt. Keep seat belt securely fastened. Falling off power unit can result in death from being run over or crushed. Keep foldable ROPS systems in "locked up" position at all times.**
- **Inspect chain, rubber, or steel band shielding before each use. Replace if damaged.**
- **Make sure shields and guards are properly installed and in good condition. Replace if damaged.**
- **Remove accumulated debris from this equipment, power unit, and engine to avoid fire hazard.**
- **Make sure all safety decals are installed. Replace if damaged. (See Safety Decals section for location.)**
- **Do not put this equipment into service unless all side skids are properly installed and in good condition. Replace if damaged.**
- **A minimum 20% of tractor and equipment weight must be on the tractor front wheels when attachments are in transport position. Without this weight, front tractor wheels could raise up resulting in loss of steering. The weight may be attained with front wheel weights, ballast in tires, front tractor weights or front loader. Weigh the tractor and equipment. Do not estimate.**
- **Inspect and clear area of stones, branches, or other hard objects that might be thrown, causing injury or damage.**

# SAFETY RULES



**ATTENTION! BECOME ALERT! YOUR SAFETY IS INVOLVED!**



## OPERATION

- To avoid damage to cutter or driveline, make sure driveline holder is properly stored before operation.
- Do not allow bystanders within 25 feet of the area when operating, attaching, removing, assembling, maintaining, or servicing equipment.
- Full chain shielding must be installed when operating in populated areas or other areas where thrown objects could injure people or damage property.
  - If this machine is not equipped with full chain shielding, operation must be stopped.
  - This shielding is designed to reduce the risk of thrown objects. The mower deck and protective devices cannot prevent all objects from escaping the blade enclosure in every mowing condition. It is possible for objects to ricochet and escape, traveling as much as 300 feet (92m).
- Never direct discharge toward people, animals, or property.
- Do not operate or transport equipment while under the influence of alcohol or drugs.
- Operate only in daylight or good artificial light.
- Keep hands, feet, hair, and clothing away from equipment while engine is running. Stay clear of all moving parts.
- Always comply with all state and local lighting and marking requirements.
- Never allow riders on power unit or attachment.
- Power unit must be equipped with ROPS or ROPS cab and seat belt. Keep seat belt securely fastened. Falling off power unit can result in death from being run over or crushed. Keep foldable ROPS system in “locked up” position at all times.
- Always sit in power unit seat when operating controls or starting engine. Securely fasten seat belt, place transmission in neutral, engage brake, and ensure all other controls are disengaged before starting power unit engine.
- Operate tractor PTO at 540 RPM. Do not exceed.
- Do not operate PTO during transport.

- Look down and to the rear and make sure area is clear before operating in reverse.
- Do not operate or transport on steep slopes.
- Do not stop, start, or change directions suddenly on slopes.
- Use extreme care and reduce ground speed on slopes and rough terrain.
- Watch for hidden hazards on the terrain during operation.
- Stop power unit and equipment immediately upon striking an obstruction. Turn off engine, set parking brake, remove key, inspect, and repair any damage before resuming operation.
- Leak down or failure of mechanical or hydraulic system can cause equipment to drop.

## MAINTENANCE

- Before performing any service or maintenance, disconnect driveline from tractor PTO.
- Before working underneath, disconnect driveline, raise cutter, lock in transport position, and block cutter securely. Hydraulic system leak down and failure of mechanical or hydraulic system can cause equipment to drop.
- Do not modify or alter or permit anyone else to modify or alter the equipment or any of its components in any way.
- Make sure attachment is properly secured, adjusted, and in good operating condition.
- Do not allow bystanders in the area when operating, attaching, removing, assembling, or servicing equipment.
- Keep all persons away from operator control area while performing adjustments, service, or maintenance.
- Make certain all movement of equipment components has stopped before approaching for service.
- Frequently check blades. They should be sharp, free of nicks and cracks, and securely fastened.
- Do not handle blades with bare hands. Wear gloves. Careless or improper handling may result in injury.



# SAFETY RULES



**ATTENTION! BECOME ALERT! YOUR SAFETY IS INVOLVED!**



- Your dealer can supply original equipment hydraulic accessories and repair parts. Substitute parts may not meet original equipment specifications and may be dangerous.
- Tighten all bolts, nuts, and screws to torque chart specifications. Check that all cotter pins are installed securely to ensure equipment is in a safe condition before putting unit into service.
- Service and maintenance work not covered in **OWNER SERVICE** must be done by a qualified dealership. Special skills, tools, and safety procedures may be required. Failure to follow these instructions can result in serious injury or death.
- Make sure all safety decals are installed. Replace if damaged. (See Safety Decals section for location.)
- Make sure shields and guards are properly installed and in good condition. Replace if damaged.

## TRANSPORTATION

- Disengage the PTO and wait for all moving parts to come to a complete stop. Raise the tractor 3-point arms to bring the cutter into transport position.
- With cutter adjusted to transport position, set upper stop on tractor lift quadrant to prevent cutter from contacting driveline while being raised.

## STORAGE

- Disconnect cutter driveshaft and secure up off ground. Raise cutter with 3-point hitch. Place blocks under cutter side skids. Lower cutter onto blocks. Disconnect cutter from tractor 3-point hitch and carefully drive tractor away from cutter.
- Keep children, bystanders and animals away from the equipment and the storage area.

# SAFETY & INSTRUCTIONAL DECALS



**ATTENTION! BECOME ALERT! YOUR SAFETY IS INVOLVED!**



**Replace Immediately If Damaged!**

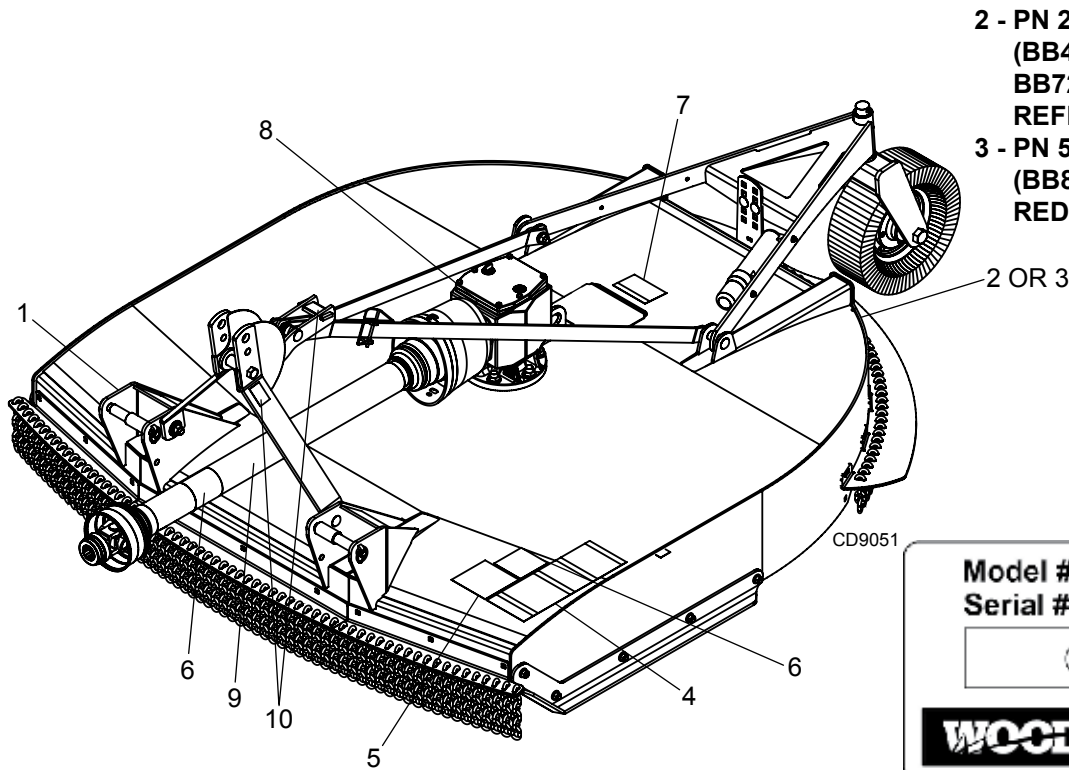

- 2 - PN 20106  
(BB48.30, BB60.30, BB72.30, BB72.40) RED REAR REFLECTOR 4.5"
- 3 - PN 57123  
(BB84.40) RED REAR REFLECTOR 9"

2 OR 3



5 - PN 15503

**⚠ DANGER**

**ROTATING BLADES AND THROWN OBJECTS**

- Do not put hands or feet under or into mower when engine is running.
- Before mowing, clear area of objects that may be thrown by blade.
- Keep bystanders away.
- Keep guards in place and in good condition.

BLADE CONTACT OR THROWN OBJECTS CAN CAUSE SERIOUS INJURY OR DEATH.

15503

1 - SERIAL NUMBER PLATE

## BE CAREFUL!

Keep safety decals clean and visible.

Use a clean, damp cloth to clean safety decals.

Avoid spraying too close to decals when using a pressure washer; high-pressure water can enter through very small scratches or under edges of decals causing them to peel or come off.

Replace safety decals if they are missing or illegible.

Replacement safety decals can be ordered free from your Woods dealer, or in the United States and Canada call 1-800-319-6637.

7 - PN 15502

⚠ WARNING

ROTATING COMPONENTS

Do not operate without cover in place. Look and listen for rotation. Do not open cover until all components have stopped.

CONTACT WITH ROTATING PARTS CAN CAUSE SERIOUS INJURY.

15502

8 - PN 1004114

**⚠ DANGER**

If shaft connection is visible, shield is missing. Replace shield before operating equipment.

1004114

# SAFETY & INSTRUCTIONAL DECALS



**ATTENTION! BECOME ALERT! YOUR SAFETY IS INVOLVED!**



**Replace Immediately If Damaged!**

4 - PN 1006681

**⚠ DANGER**

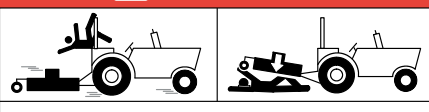

**FALLING OFF WILL RESULT IN BEING RUN OVER.**

- Tractor must be equipped with ROPS (or ROPS CAB) and seat belt. Keep foldable ROPS systems in "locked up" position at all times.
- Buckle Up! Keep seat belt securely fastened.
- Never allow riders on mower or tractor.

**RAISED EQUIPMENT CAN DROP AND CRUSH.**

- Before working underneath, follow all instructions and safety rules in operator's manual and securely block up all corners of equipment with jack stands.
- Securely blocking prevents equipment from dropping from hydraulic leakdown, hydraulic system failures or mechanical component failures.

**FALLING OFF OR FAILING TO BLOCK SECURELY WILL RESULT IN SERIOUS INJURY OR DEATH.**

**⚠ WARNING**

**TO AVOID SERIOUS INJURY OR DEATH:**

- Read Operator's Manual (available from dealer) and follow all safety precautions.
- Keep all shields in place and in good condition.
- Operate mower from tractor seat only.
- Lower mower, stop engine and remove key before dismounting tractor.
- Allow no children or untrained persons to operate equipment.
- Do not transport towed or semi-mounted units over 20 mph (30 km/h).

**FAILURE TO OPERATE SAFELY CAN RESULT IN INJURY OR DEATH.**

**⚠ WARNING**



**CRUSHING AND PINCHING HAZARD**

- Be extremely careful handling various parts of the machine. They are heavy and hands, fingers, feet, and other body parts could be crushed or pinched between tractor and implement.
- Operate tractor controls from tractor seat only.
- Do not stand between tractor and implement when tractor is in gear.
- Make sure parking brake is engaged before going between tractor and implement.
- Stand clear of machine while in operation or when it is being raised or lowered.

**FAILURE TO FOLLOW THESE INSTRUCTIONS COULD RESULT IN SERIOUS INJURY OR DEATH.**

**⚠ WARNING**



**DO NOT EXCEED PTO SPEED OF 540 RPM**

PTO speeds higher than 540 RPM can cause equipment failure and personal injury.

**⚠ CAUTION**



**CUTTER DECK SURFACE IS SLIPPERY**  
Avoid walking on deck

1006681 AD

6 - PN 18864

**⚠ DANGER**



**ROTATING DRIVELINE CONTACT CAN CAUSE DEATH**  
**KEEP AWAY!**  
**DO NOT OPERATE WITHOUT -**

- All driveline guards, tractor and equipment shields in place.
- Drivelines securely attached at both ends.
- Driveline guards that turn freely on driveline.
- Read the operator's manual.
- Do not use PTO adapters.

18864

9 - PN 33347

**⚠ DANGER**



**GUARD MISSING.**  
**DO NOT OPERATE.**

**⚠ DANGER**



**GUARD MISSING.**  
**DO NOT OPERATE.**

33347

**⚠ DANGER**

10 - PN 603626

**⚠ WARNING**



**PINCH POINT**  
**Do not push here**



603626

# OPERATION

The operator is responsible for the safe operation of the cutter. The operator must be properly trained. Operators should be familiar with the cutter, the tractor, and all safety practices before starting operation. Read the safety rules and safety decals on page 7 to page 11. Be sure to complete the Pre-Operation Checklist on page 17 before operating this cutter.

The intended use of this heavy-duty cutter is for grass and weed mowing and shredding applications.

Recommended mowing speed for most conditions is from 2 to 5 mph.

## **! DANGER**

- Full chain shielding must be installed when operating in populated areas or other areas where thrown objects could injure people or damage property.
  - If the machine is not equipped with full chain shielding, operation must be stopped.
  - This shielding is designed to reduce the risk of thrown objects. The mower deck and protective devices cannot prevent all objects from escaping the blade enclosure in every mowing condition. It is possible for objects to ricochet and escape, traveling as much as 300 feet (92m).

## **! WARNING**

- Never allow riders on power unit or attachment.
- Operate tractor PTO at 540 RPM. Do not exceed.
- Do not allow bystanders within 25 feet of the area when operating, attaching, removing, assembling, maintaining, or servicing equipment.

## **! CAUTION**

- Stop power unit and equipment immediately upon striking an obstruction. Turn off engine, remove key, inspect, and repair any damage before resuming operation.
- Always wear relatively tight and belted clothing to avoid entanglement in moving parts. Wear sturdy, rough-soled work shoes and protective equipment for eyes, hair, hands, hearing, and head; and respirator or filter mask where appropriate.

## TRACTOR STABILITY

### **! WARNING**

- A minimum 20% of tractor and equipment weight must be on the tractor front wheels when attachments are in transport position. Without this weight, tractor could tip over, causing personal injury or death. The weight may be attained with front wheel weights, ballast in tires or front tractor weights. Weigh the tractor and equipment. Do not estimate.

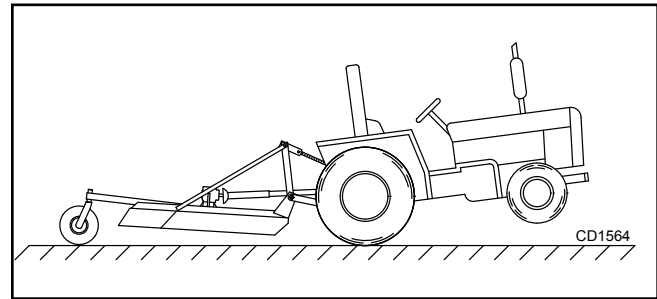

Figure 1. Tractor Stability

## ATTACHING CUTTER TO TRACTOR - BB48.30, BB60.30, BB72.30

Refer to Figure 2.

### Category 1 Standard Hitch

1. Position tractor lower lift arms between hitch mast plates.
2. Secure with hitch pins (1) and klik pins (2).
3. Attach the tractor's top link to the top hole of the A-Frame bars (4). Secure with the heavy-duty top link pin and retaining pin supplied with the tractor top link.

### Category 1 Quick Hitch

Refer to Figure 2.

1. Place 1-7/16" OD bushings (3) over hitch pins (1) and secure into position with klik pins (2).
2. Align Quick Hitch with lower bushings (3) and upper sleeve (5) located between A-Frame bars and break link.

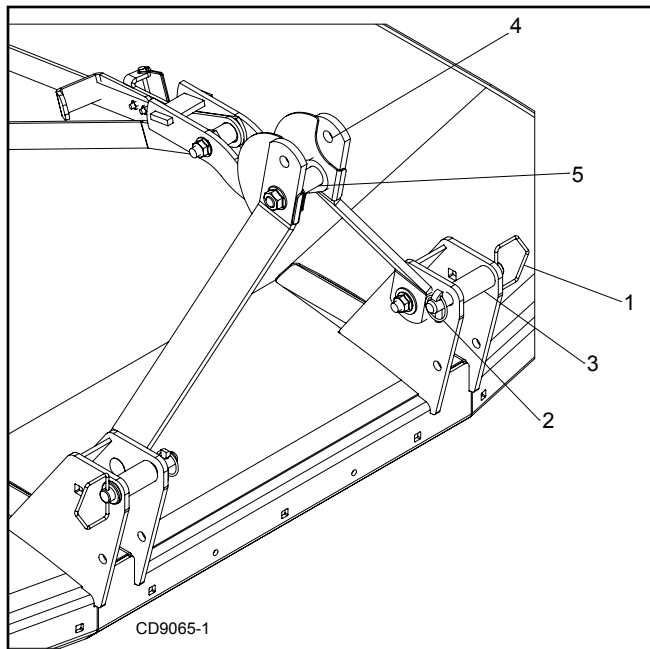

**Figure 2.** Cat 1 Standard & Quick Hitch Connection  
BB48.30, BB60.30, BB72.30 Models

## **ATTACHING CUTTER TO TRACTOR - BB72.40, BB84.40**

Refer to Figure 3.

### **Category 1 Standard Hitch**

1. Position tractor lower lift arms between hitch mast plates.
2. Insert lower hitch pins (1) through mast plates and tractor lift arms. Use 1-1/8" OD sleeves (3) to keep lift arms in positions. Secure with klik pins (2).
3. Attach the tractor's top link to the middle hole of the A-Frame bars (5). Secure with the heavy-duty top link pin and retaining pin supplied with the tractor top link.

### **Category 2 Standard Hitch**

1. Position tractor lower lift arms between hitch mast plates.
2. Insert lower hitch pins (1) and 1-1/8" OD sleeves (3) through mast plates and lower lift arms. Use 1- 7/16" OD sleeve (4) to keep lift arms in position. Secure with klik pins (2).
3. Attach the tractor's top link to the upper hole of the A-Frame bars (6). Secure with the heavy-duty top link pin and retaining pin supplied with the tractor top link.

### **Category 1 & 2 Quick Hitch**

1. Insert lower hitch pins (1), 1-1/8" OD sleeves (3) and 1-7/16" OD sleeves (4) through mast plates.

For Category 1 Quick Hitch, place the 1-7/16 OD sleeve (4) against the inner mast plate.

For Category 2 Quick Hitch, place the 1-7/16" OD sleeve (4) against the outer mast plate.

2. Secure with the klik pins (2).
3. Align Quick Hitch with lower sleeves (2 or 3) and upper sleeve (7) located between A-Frame bars and break link.

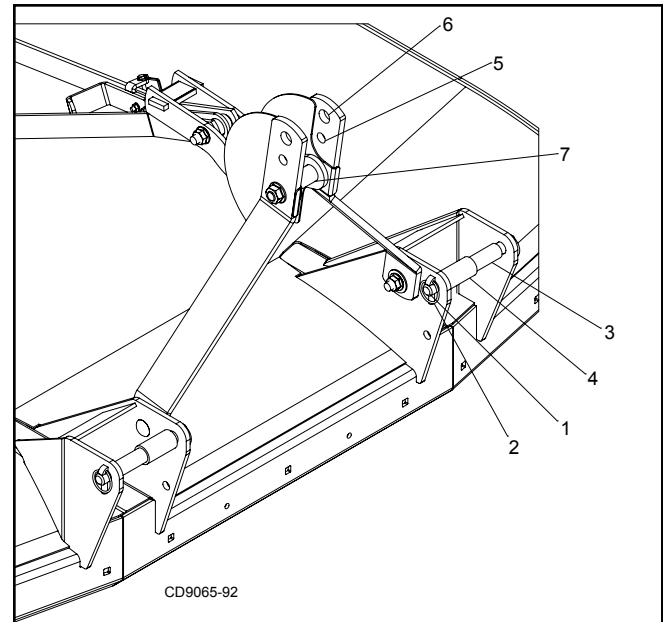

**Figure 3.** Cat 1 & 2 Standard & Quick Hitch Connection - BB72.40, BB84.40 Model Only

## **DRIVELINE ATTACHMENT**

### **⚠ CAUTION**

- **Make sure driveline will not bottom out at the shortest length and that it has at least 4" overlap at the longest length.**

Attach the cutter to the tractor 3-point hitch (or quick hitch if available). Do not attach driveline. Raise and lower cutter to determine maximum and minimum distance between the tractor PTO shaft and the gearbox input shaft. If the distance is too large, the driveline will be too short for proper engagement. If distance is too small, the driveline may bottom out in operation and damage the cutter or tractor.

There must be at least 4 inches of engagement at the cutter's lowest possible point of operation.

If driveline is too short, please call your Woods dealer for a longer driveline.

The driveline must not bottom out when raised to the maximum height possible.

If driveline is too long, please follow the instructions for shortening the driveline.

## INSTALLATION AND REMOVAL OF DRIVELINE (TRACTOR PTO)

### **CAUTION**

- To avoid damage to cutter or driveline, make sure driveline holder is properly stored before operation.

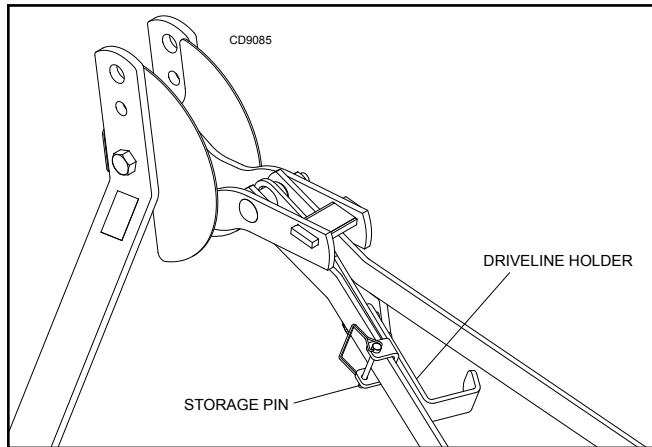

Figure 4. Driveline Holder Storage Position

### To Install:

Pull locking collar back and at the same time push driveline onto tractor PTO shaft until locking device engages.

### To Remove:

Hold driveline into position, pull locking collar back, and slide driveline off tractor PTO shaft.

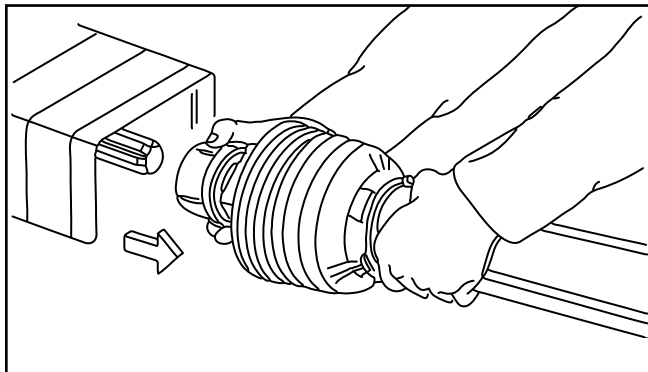

Figure 5. Lock Collar

## SHORTENING DRIVELINE

1. Move mower up and down to measure the shortest possible distance between tractor PTO shaft and gearbox input shaft.
2. Separate driveline into two halves and connect them to the tractor PTO and gearbox.
3. Place driveline halves parallel to one another to determine how much to shorten the driveline.



Figure 6. Drive Halves Placed Parallel

4. Measure from end of the upper shield to the base of the bell on the lower shield (A). Add 1-9/16" to dimension (A). See Figure 7.

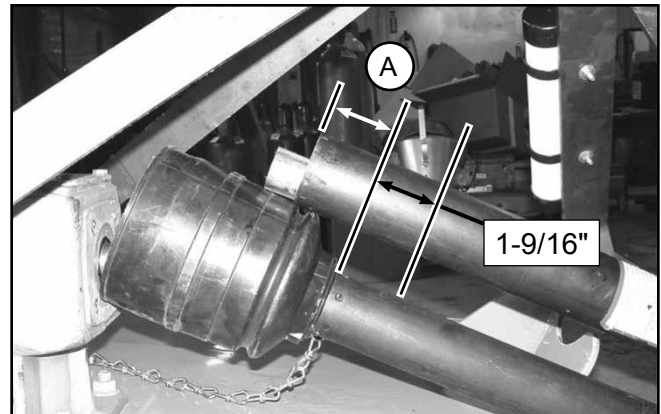
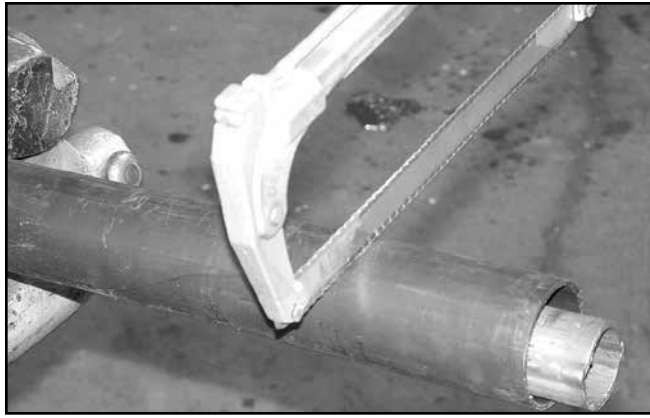

Figure 7. Determine Shield Length

5. Cut the shield to the overall dimension.



**Figure 8.** Cut Shield

6. Place the cut-off portion of the shield against the end of the shaft and use as a guide. Mark and cut the shaft.



**Figure 9.** Cut Shaft to Length

7. Repeat step 6 for the other half of the drive.
8. File and clean cut ends of both drive halves.

Do not use tractor if proper driveline engagement cannot be attained through these methods.

Connect driveline to tractor PTO shaft, making sure the spring-activated locking collar slides freely and locks driveline to PTO shaft.

### **NOTICE**

- **If attaching with quick hitch, the distance between the tractor PTO and gearbox input shaft will increase. Follow the steps as you would for a 3-point hitch to ensure proper engagement.**

### **DRIVELINE INTERFERENCE CHECK**

1. Check for proper clearance between driveline and mower deck.
2. Slowly lift mower and observe driveline. If clearance between driveline and mower deck is less than 1 inch, shorten top link or limit upper travel of lower hitch arms. Refer to tractor operator's manual for instructions.

### **CUTTING HEIGHT ADJUSTMENT**

Refer to Figure 10.

#### **⚠ WARNING**

- **Keep all persons away from operator control area while performing adjustments, service, or maintenance.**
- **Avoid low cutting heights. Striking the ground with blades produces one of the most damaging shock loads a cutter can encounter. Allowing blades to contact ground repeatedly will cause damage to cutter and drive.**
- **When making cutting height adjustments, do not put fingers in bolt holes. Parts can shift and injury will occur. Use proper tool to align hole.**

When selecting a cutting height, you should consider the area of operation. If the ground is rolling and has mounds the blades could contact, set the cutting height accordingly.

1. Level cutter from side to side. Check by measuring from cutter frame to the ground at each deck rail.
2. Adjust, using tractor 3-point arm leveling device.

**NOTE:** Keep the front of cutter level with or slightly lower than rear for best mowing.

3. Control cutting height with tractor 3-point arms, rear tailwheel adjustment, or optional check chains.
4. To raise rear of cutter, move tailwheel down.
5. To raise front of cutter, raise tractor 3-point arms or shorten optional check chains.

The cutting height is the distance between the blade and the ground. The blades are approximately 1" above the skid shoe. To check cutting height, do the following:

- a) Select a cutting height; as an example, for an approximate cutting height of 3", set the skid shoe 2" above the ground.
 

3" Desired cutting height	-	1" Distance blade cutting edge is above skid shoe	=	2" Distance skid shoe is above ground
---------------------------	---	---	---	---------------------------------------
- b) Adjust the front-to-rear attitude from 1/2" to 3/4" higher than the front.
6. Adjust top link such that the lower rear corner of the link is in line with the top edge of the lift arms. The clearance will allow cutter to float over uneven terrain.

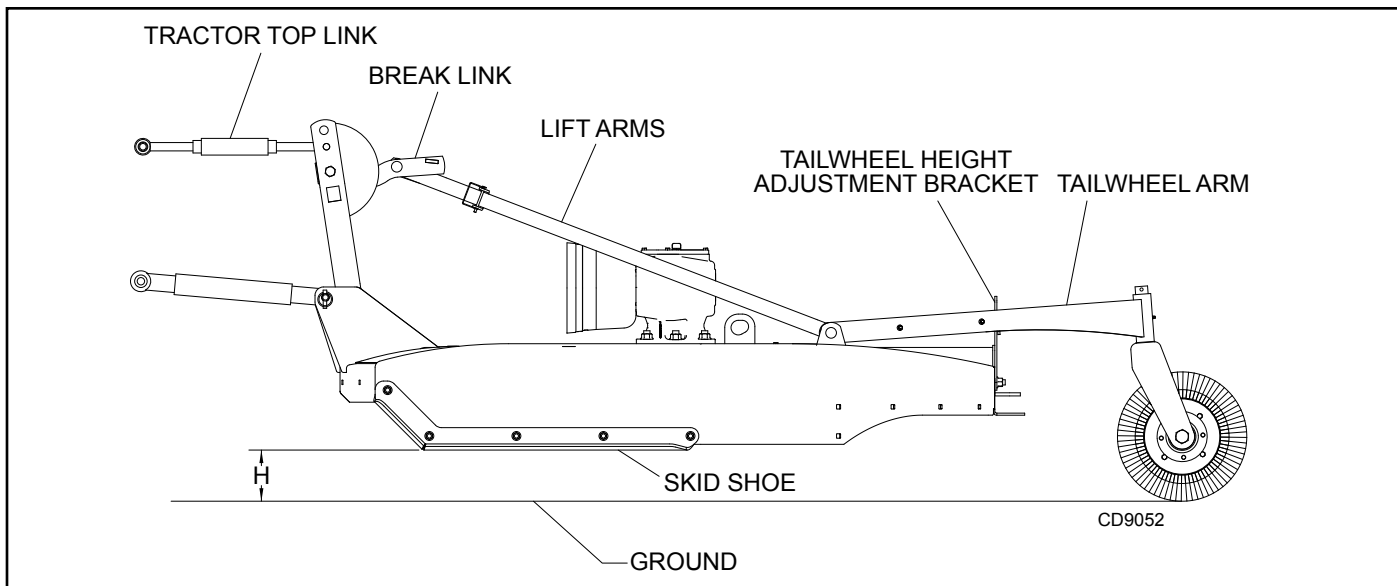

**Figure 10.** Cutting Height Adjustment

### **SHREDDING MATERIAL HEIGHT ADJUSTMENT**

For shredding, set the cutter lower at rear. Determine how much lower to set the rear by experimenting in different situations.

### **CHECK CHAIN ADJUSTMENT (OPTIONAL)**

1. Refer to Install Optional Check Chains, page 34 for check chain installation.
2. After making cutting height adjustment, adjust both chains (3) in check chain bracket (2) so you have the same number of links on each side. This will keep your cutting level.

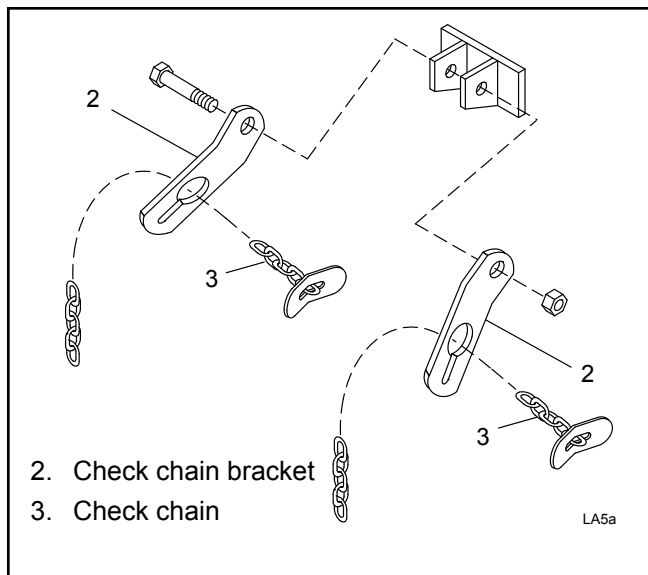

**Figure 11.** Check Chain Adjustment

### **OPERATING TECHNIQUE**

1. Power for operating the cutter is supplied by the tractor PTO. Operate PTO at 540 RPM. Know how to stop the tractor and cutter quickly in an emergency.
2. Engage PTO at a low engine RPM to minimize stress on the drive system and gearbox. With PTO engaged, raise PTO speed to 540 RPM and maintain throughout cutting operation.

Gearbox protection is provided by a slip clutch with replacement fiber disc. The slip clutch is designed to slip when excessive torsional loads occur.

3. Move slowly into material. Adjust tractor ground speed to provide a clean cut without lugging the tractor engine. Use a slow ground speed for better shredding.

Proper ground speed will depend on the terrain and the material's height, type, and density.

Normally, ground speed will range from 2 to 5 mph. Tall, dense material should be cut at a low speed; thin, medium-height material can be cut at a faster ground speed.

4. Always operate tractor PTO at 540 RPM to maintain proper blade speed and to produce a clean cut.
5. Under certain conditions tractor tires may roll down some grass and prevent cutting at the same height as the surrounding area. When this occurs, reduce your ground speed but maintain PTO at 540 RPM. The lower ground speed will permit grass to rebound partially.



## TRANSPORTING

### **WARNING**

- Disengage the PTO and wait for all moving parts to come to a complete stop. Raise the tractor 3-point arms to bring the cutter into transport position.
- With cutter adjusted to transport position, set upper stop on tractor lift quadrant to prevent cutter from contacting driveline while being raised.

## STORAGE

### **WARNING**

- **Keep children, bystanders and animals away from equipment and storage area.**
1. Disconnect cutter driveshaft and secure up off ground. Raise cutter with 3-point hitch.
  2. Place blocks under cutter side skids.
  3. Lower cutter onto blocks.
  4. Disconnect cutter from tractor 3-point hitch and carefully drive tractor away from cutter.
  5. Perform **Pre-Operation Checklist** when returning to use.

## PRE-OPERATION CHECKLIST

### (OWNER'S RESPONSIBILITY)

- \_\_\_\_\_ Review and follow all safety rules and safety decal instructions on page 7 through page 11.
- \_\_\_\_\_ Check that equipment is properly and securely attached to tractor.
- \_\_\_\_\_ Make sure driveline spring-activated locking pin or collar slides freely and is seated firmly in tractor PTO spline groove.
- \_\_\_\_\_ Lubricate all grease fitting locations. Make sure PTO shaft slip joint is lubricated.
- \_\_\_\_\_ Check to be sure gear lube is above the lower line on dipstick.
- \_\_\_\_\_ Check that all hardware is properly installed and secured.
- \_\_\_\_\_ Check that blades are sharp and secure and cutting edge is positioned to lead in a counter-clockwise rotation.
- \_\_\_\_\_ Check that shields and guards are properly installed and in good condition. Replace if damaged.
- \_\_\_\_\_ Check cutting height, front-to-rear attitude, and top link adjustment.
- \_\_\_\_\_ Set tractor PTO at 540 RPM.
- \_\_\_\_\_ Place tractor PTO and transmission in neutral before starting engine.
- \_\_\_\_\_ Inspect area to be cut and remove stones, branches, or other hard objects that might be thrown and cause injury or damage.

# OWNER SERVICE

The information in this section is written for operators who possess basic mechanical skills. If you need help, your dealer has trained service technicians available. For your protection, read and follow the safety information in this manual.

## WARNING

- **Keep all persons away from operator control area while performing adjustments, service, or maintenance.**

## CAUTION

- **If you do not understand any part of this manual and need assistance, see your dealer.**
- **Always wear relatively tight and belted clothing to avoid entanglement in moving parts. Wear sturdy, rough-soled work shoes and protective equipment for eyes, hair, hands, hearing, and head; and respirator or filter mask where appropriate.**

## BLOCKING METHOD

### WARNING

- **Before performing any service or maintenance, disconnect driveline from tractor PTO.**
- **Never go underneath equipment (lowered to the ground or raised) unless it is properly blocked and secured. Never place any part of the body underneath equipment or between moveable parts even when the engine has been turned off. Hydraulic system leak down, hydraulic system failures, mechanical failures, or movement of control levers can cause equipment to drop or rotate unexpectedly and cause severe injury or death. Follow Operator's Manual instructions for working underneath and blocking requirements or have work done by a qualified dealer.**

To minimize the potential hazards of working underneath the cutter, follow these procedures:

1. Jackstands with a load rating of 1000 lbs. or more are the only approved blocking device for this cutter. Install jackstands (shown by Xs in Figure 12) under the cutter before working underneath unit.

Do not position jackstands under wheels, axles, or wheel supports. Components can rotate and cause cutter to fall.

2. Consider the overall stability of the blocked unit. Just placing jackstands underneath will not ensure your safety.

The working surface must be level and solid to support the weight on the jackstands. Make sure jackstands are stable, both top and bottom. Make sure cutter is approximately level.

3. With full cutter weight lowered onto jackstands, test blocking stability before working underneath.
4. If cutter is attached to tractor when blocking, set the brakes, remove key, and block cutter before working underneath.
5. Securely block rear tractor wheels, in front and behind. Tighten tractor lower 3-point arm anti-sway mechanism to prevent side-to-side movement.

## LUBRICATION INFORMATION

1. Do not let excess grease collect on or around parts, particularly when operating in sandy areas.
2. See Figure 12 for lubrication points and frequency or lubrication based on normal operating conditions. Severe or unusual conditions may require more frequent lubrication.
3. Use a lithium grease of #2 consistency with a MOLY (molybdenum disulfide) additive for all locations unless otherwise noted. Be sure to clean fittings thoroughly before attaching grease gun. One good pump of most guns is sufficient when the lubrication schedule is followed.

### **Gearbox Lubrication**

1. For gearbox, use a high quality gear oil with a viscosity index of 80W or 90W and an API service rating of GL-4 or -5 in gearboxes.
2. Fill gearbox until oil is above lower line on dipstick. Check gearbox daily for evidence of leakage, and contact your dealer if leakage occurs.

### **Driveline Lubrication**

1. Lubricate the driveline slip joint every ten operating hours. Failure to maintain proper lubrication could result in damage to U-joints, gearbox, and driveline.
2. Lower cutter to ground, disconnect driveline from tractor PTO shaft, and slide halves apart but do not disconnect from each other.
3. Apply a bead of grease completely around male half where it meets female half. Slide drive halves over each other several times to distribute grease.

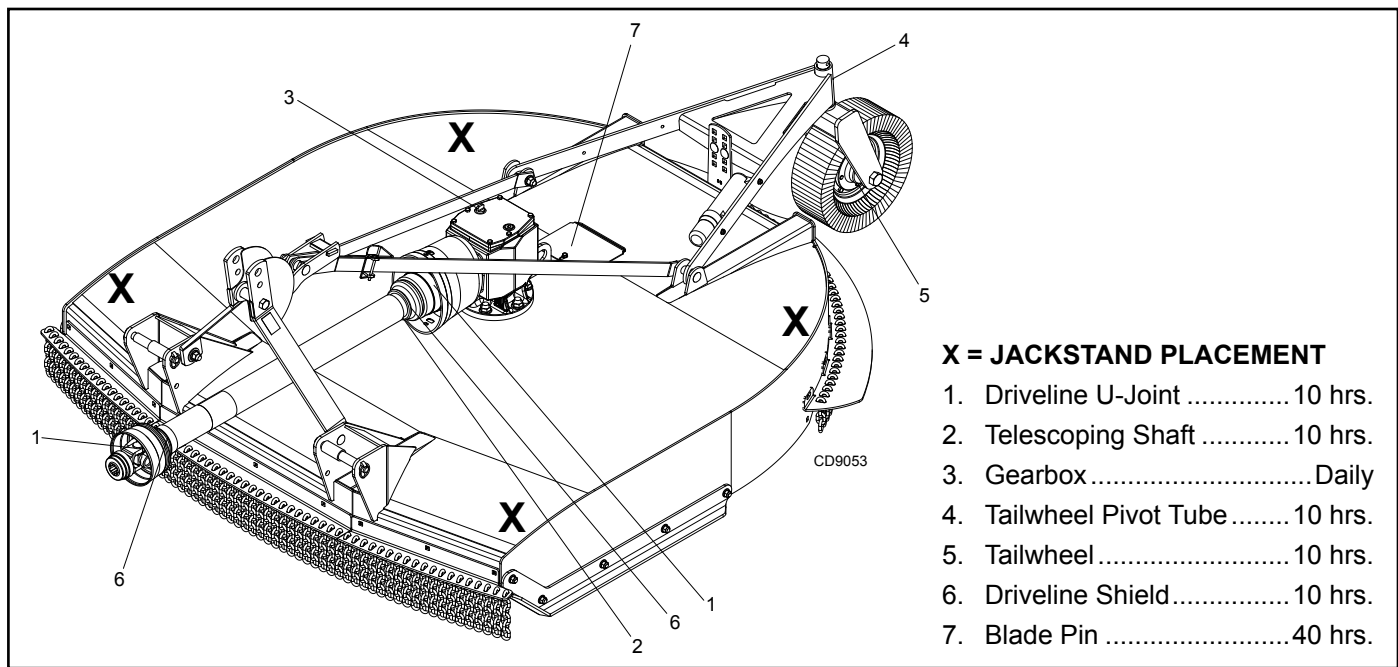

Figure 12. Jackstand Placement and Lubrication Points

## BLADE SERVICING

### Blade Removal

Refer to Figure 13.

### NOTICE

- When sharpening blades, grind the same amount on each blade to maintain balance. Replace blades in pairs. Unbalanced blades will cause excessive vibration, which can damage gearbox bearings. Vibration may also cause structural cracks to cutter.
- If blade pin (7) is seized in crossbar and extreme force will be needed to remove it, support crossbar from below to prevent gearbox damage.

1. Disconnect driveline from tractor PTO.
2. Raise cutter and block securely (see Blocking Method, Figure 12).
3. Align crossbar (2) with blade access hole in the cutter frame. Remove cap screw, blade pin lock clip, keyhole plate, and shims. Carefully drive pin out of crossbar.
4. Rotate crossbar and repeat for opposite blade.

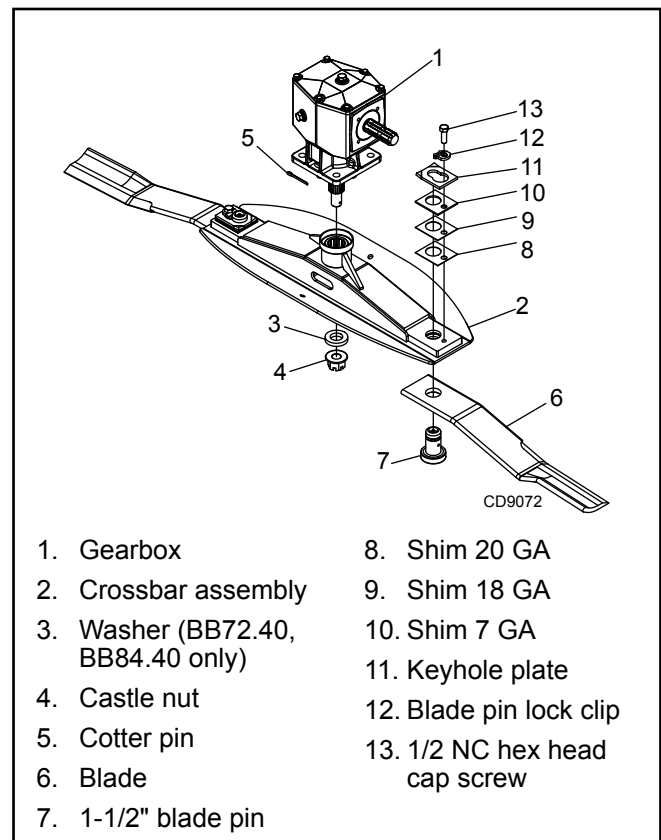

Figure 13. Blade Assembly

## Blade Installation

Refer to Figure 13.

### **CAUTION**

- Your dealer can supply genuine replacement blades. Substitute blades may not meet original equipment specifications and may be dangerous.
- Crossbar rotation is counterclockwise when looking down on cutter. Be sure to install blade cutting edge to lead in counterclockwise rotation.

1. Inspect blade pin (7) for nicks or gouges, and if you find any replace the blade pin.
2. Insert blade pin through the blade. Blade should swivel on blade pin; if it doesn't determine the cause and correct.
3. Align crossbar (2) with blade access hole in cutter frame. Apply a liberal coating of Never Seez® or equivalent to blade pin and crossbar hole. Make sure blade offset is away from cutter. Push blade pin through crossbar. Pin should rotate freely prior to installing blade clip (12).
4. Install shims (8, 9 & 10) over blade pin.

**NOTE:** Only use enough shims to allow keyhole plate (11) to slide into blade pin groove.

5. Install blade clip (12) over keyhole plate and into blade pin groove.
6. Secure into position with cap screw (13). Torque cap screw to 85 lbs-ft.
7. Repeat steps for opposite side.

**NOTE:** Blade should be snug but should swivel on pin without having to exert excessive force. Blade should not move more than a 1/4 inch up or down at the tip. Keep any spacers not used in the installation as replacements or for future installation.

## Blade Sharpening

1. Sharpen both blades at the same time to maintain balance. Follow original sharpening pattern.
2. Do not sharpen blade to a razor edge—leave at least a 1/16" blunt edge.
3. Do not sharpen back side of blade.

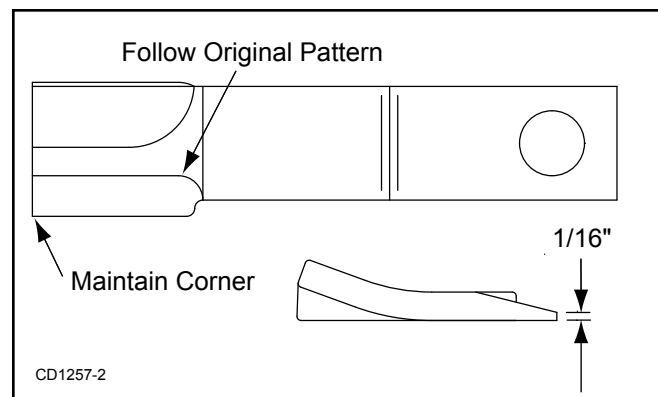

Figure 14. Blade Sharpening

## SLIP CLUTCH ADJUSTMENT

The slip clutch is designed to slip so that the gearbox and driveline are protected if the cutter strikes an obstruction.

A new slip clutch or one that has been in storage over the winter may seize. Before operating the cutter, make sure it will slip by performing the following operation:

### Compression Spring Style Clutch

1. Turn off tractor engine and remove key.
2. Loosen nuts on springs until the springs can rotate freely, yet remain secure on the bolts.
3. Mark outer plates of slip-disc clutch as shown in Figure 15.
4. Securely attach implement to the tractor and start the tractor.
5. Engage PTO for several seconds then quickly disengage it.
6. Turn tractor off and remove key.
7. The friction lining plates should have "slipped". Check the marks placed on the outer plates of the slip-disc clutch in step 3 to make sure this is the case.
8. If clutch does not slip, check assembly for oil, grease and debris. Clean if necessary.
9. Reassemble clutch and tighten bolts no more than 1/8 of a turn at a time until desired setting of 1.12" on BB48.30, BB60.30, and BB72.30 cutters is reached. For BB72.40, BB84.40 cutters, set to 1.24". See Figure 15.
10. If excessive slippage continues, check lining plates for excessive wear. They are 1/8" thick when new and should be replaced after 1/32" of wear to ensure proper operation.

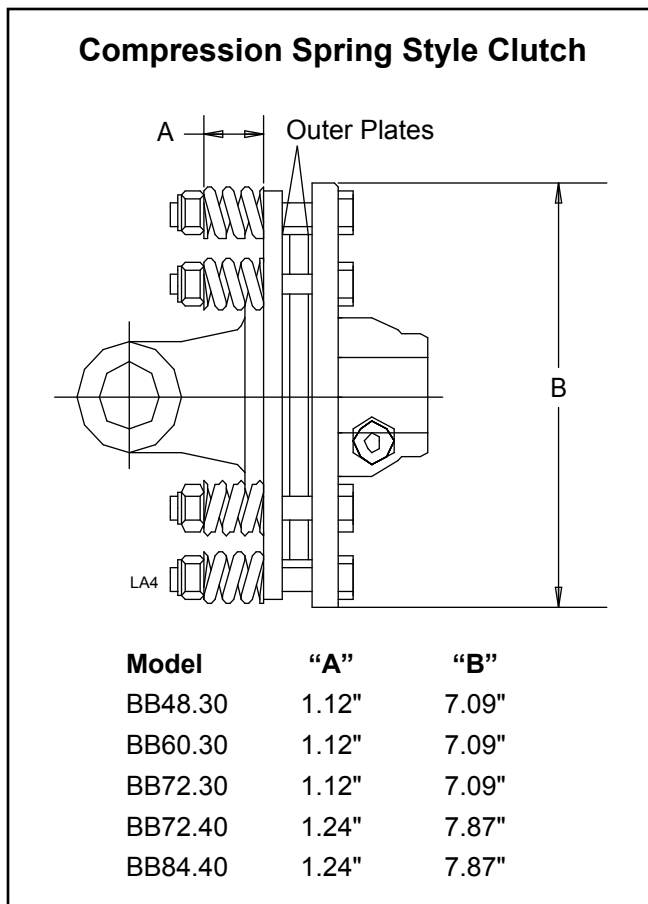

Figure 15. Slip Clutch Assembly

## SHIELDING REPAIR

### **! DANGER**

- Full chain shielding must be installed when operating in populated areas or other areas where thrown objects could injure people or damage property.
  - If the machine is not equipped with full chain shielding, operation must be stopped.
  - This shielding is designed to reduce the risk of thrown objects. The mower deck and protective devices cannot prevent all objects from escaping the blade enclosure in every mowing condition. It is possible for objects to ricochet and escape, traveling as much as 300 feet (92m).

## Rear Band

Inspect rear band each day of operation and replace if bent, cracked or broken.

## Rubber Shielding

Inspect rubber shielding each day of operation and replace if cracked or broken.

## Chain Shielding

Inspect chain shielding each day of operation and replace any broken or missing chains as required.

Inspect chain brackets and replace if bent, cracked, or broken.

## CLEANING CUTTER

### After Each Use

- Remove large debris such as clumps of dirt, grass, crop residue, etc. from machine.
- Inspect machine and replace worn or damaged parts.
- Replace any safety decals that are missing or not readable.

### Periodically or Before Extended Storage

- Clean large debris such as clumps of dirt, grass, crop residue, etc. from machine.
- Remove the remainder using a low-pressure water spray.
  1. Be careful when spraying near scratched or torn safety decals or near edges of decals as water spray can peel decal off surface.
  2. Be careful when spraying near chipped or scratched paint as water spray can lift paint.
  3. If a pressure washer is used, follow the advice of the pressure washer manufacturer.
- Inspect machine and replace worn or damaged parts.
- Sand down scratches and the edges of areas of missing paint and coat with Woods spray paint of matching color (purchase from your Woods dealer).
- Replace any safety decals that are missing or not readable (supplied free by your Woods dealer).
- See Safety Decals section for location drawing.

# TROUBLESHOOTING

## MOWING CONDITIONS

PROBLEM	POSSIBLE CAUSE	SOLUTION
Grass cut lower in center of swath than at edge	Height of cutter lower at rear or front	Adjust cutter height and attitude so that cutter rear and front are within 1/2" of same height.
Material discharges from cutter unevenly; bunches of material along swath	Conditions too wet for mowing	Allow grass to dry before mowing.
	Blades unable to cut that part of grass pressed by path of tractor tires	Slow ground speed of tractor but keep engine running at full PTO rpm. Cutting lower will help.
	Dull blades	Sharpen or replace blades.
Cutter will not cut all the time (Slip clutch drive only)	Material too high and too much material	Reduce ground speed but maintain 540 RPM at tractor PTO or make two passes over material. Raise cutter for the first pass and lower to desired height for the second and cut at 90° to first pass. Raise rear of cutter high enough to permit material to discharge but not so high to cause conditions listed above.
	Grass wet	Allow grass to dry before mowing. Slow ground speed of tractor but keep engine running at full PTO rpm. Cutting lower will help
	Rear of cutter too low, trapping material under cutter	Adjust cutter height and attitude.
Cutter will not cut all the time (Slip clutch drive only)	Slip clutch slipping	Adjust slip clutch according to instructions in SLIP CLUTCH adjustment, page 20.

# DEALER SERVICE

The information in this section is written for dealer service personnel. The repair described here requires special skills and tools. If your shop is not properly equipped or your mechanics are not properly trained in this type of repair, do not attempt this repair.

## ⚠ WARNING

- Before working underneath, read manual instructions, securely block up, and check stability. Secure blocking prevents equipment from dropping due to hydraulic leak down, hydraulic system failure, or mechanical component failure.
- Keep all persons away from operator control area while performing adjustments, service, or maintenance.

## ⚠ CAUTION

- Always wear relatively tight and belted clothing to avoid getting caught in moving parts. Wear sturdy, rough-soled work shoes and protective equipment for eyes, hair, hands, hearing, and head; and respirator or filter mask where appropriate.

## GEARBOX MAINTENANCE

**NOTE:** Read this entire section before starting any repair. Many steps are dependent on each other.

1. Fill gearbox with SAE 80W or 90W gear lube until it runs out the side level plug.

**NOTE:** Repair to this gearbox is limited to replacing bearings, seals, and gaskets. Replacing gears, shafts, and a housing is not cost effective. Purchasing a complete gearbox is more economical.

2. Inspect gearbox for leakage and bad bearings. Leakage is a very serious problem and must be corrected immediately.

## Seal Replacement

Recommended sealant for gearbox repair is Permatex® Aviation 3D Form-A-Gasket or equivalent.

Leakage can occur at the vertical or horizontal gaskets and shaft seals.

Leakage at the horizontal gasket or seal can be repaired without removing the gearbox from the cutter.

## Seal Installation

**NOTE:** Proper seal installation is important. An improperly installed seal will leak.

1. Clean area in housing where seal outer diameter (OD) seats. Apply a thin coat of Permatex.
2. Inspect area of shaft where seal seats. Remove any burrs or nicks with an emery cloth.
3. Lubricate gear shaft and seal lips.
4. Place seal squarely on housing, spring-loaded lip toward housing. Select a piece of pipe or tubing with an OD that will sit on the outside edge of the seal but will clear the housing. Tubing with an OD that is too small will bow seal cage and ruin seal.
5. Carefully press seal into housing, avoiding distortion to the metal seal cage.

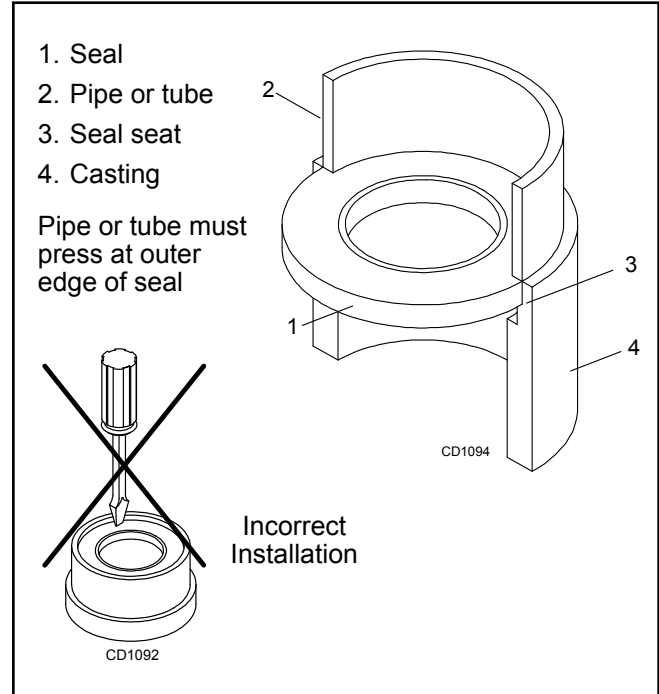

Figure 16. Seal Installation

## **GEARBOX REPAIR - BB48.30, BB60.30, BB72.30**

Refer to Figure 17.

**NOTE:** Repair to this gearbox is limited to replacing bearings, seals, and gaskets. Replacing gears, shafts, and a housing is not cost effective. Purchasing a complete gearbox is more economical.

Gearbox is heavy: do not attempt to move without mechanical assistance.)

### **Remove Gearbox from Cutter**

1. Disconnect and remove the driveline from the gearbox.
2. Remove vent plug (9) and siphon gear lube from housing through this opening.
3. Remove cotter pin or wire, washer, and nut from vertical shaft and remove crossbar (see Crossbar Removal, page 28).
4. Remove the four bolts that attach gearbox to cutter and remove gearbox.

### **Disassemble Gearbox**

1. Remove plug from side of gearbox and pour out remaining gear oil.
  2. Support housing in vise in a vertical position.
  3. Remove input seal (4) (to be replaced).
  4. Remove retaining rings (6) and (8).
  5. Remove the six cap screws (24), washers (23) and top cover (2) from housing.
  6. Remove retaining ring (6) behind gear (3).
  7. Support gearbox in hand press and pull input shaft (5) through gear (3). Remove ball bearing (21).
  8. Remove ball bearing (20) and gear spacer (7) from input shaft (5).
  9. Support housing in vise in a horizontal position.
  10. With the hub/stump jumper/crossbar, castle nut, cotter pin, wire and washer already removed, remove the four cap screws (13), lock washers (12) and output cap (17).
  11. Remove output gaskets (11) and (10).
  12. Push output shaft and pinion (19) down and remove ball bearing (20) or tapered roller bearings (25), output bearing spacer (18), and retaining ring (6). Remove output shaft and pinion (19).
- NOTE:** On gearboxes with tapered roller bearings, it will be necessary to use a punch to drive out bearing cups.
13. Inspect gears for broken teeth and wear. Some wear is normal and will show on loaded side. Forged gear surfaces are rough when new. Check that wear pattern is smooth.

14. Inspect vertical and horizontal shafts for grooves, nicks, or bumps in the areas where the seals seat. Resurface any damage with emery cloth.
15. Inspect housing and caps for cracks or other damage.

## **SEAL REPAIR - BB48.30, BB60.30, BB72.30**

Refer to Figure 17.

### **Vertical Shaft Seal Repair**

1. Disconnect and remove the rear driveline from the gearbox.
2. Remove vent plug (9) and siphon gear lube from housing through this opening.
3. Remove crossbar (see Crossbar Removal, page 28).
4. Remove output cap (17) and output seal (16) by removing four cap screws (13) and washers (12). Replace with new seal (see Seal Installation, page 23).

Vertical seal should be recessed in output cap.

**NOTE:** Distortion to seal cage or damage to seal lip will cause seal to leak.

5. Secure output cap (17) on to bottom of gearbox using four cap screws (13) and lock washers (12).
- NOTE:** Make sure output gasket (10) and (11) are in place.
6. Fill gearbox with SAE 80W or 90W gear lube until it runs out the side level plug.
  7. Remove and replace any seal damaged in installation.

### **Horizontal Seal Leak Repair**

1. Disconnect and remove the rear driveline from the gearbox.
2. Remove vent plug (9) and siphon gear lube from housing through this opening.
3. Remove input seal (4). Replace with new one (refer to Seal Installation, page 23).

Fill gearbox with SAE 80W or 90W gear lube until it runs out the side level plug.

## **Reassemble Gearbox - BB48.30, BB60.30, BB72.30**

1. Clean housing, paying specific attention to areas where gaskets will be installed.
2. Wash housing and all components thoroughly. Select a clean area for gearbox assembly. Replace all seals, bearings, and gaskets. All parts must be clean and lightly oiled before reassembling.



3. Insert upper output bearing cups (25) in the housing and press using a round tube with the correct diameter.
4. Slide shims (26) over output shaft (16). Use the same thickness as removed as a starting point.
5. Push bearing cone (25) onto output shaft (16). Shims maybe required between cone (25) and retaining ring (6) to eliminate any space.

**NOTE:** Make sure there is no endplay or gaps in this assembly.

6. Insert output bearing spacer (18) and bearing cone (25) over output shaft until seats against upper bearing (25). Press lower bearing cup into position as shown.
7. Secure output cap (17) with new output seal (16) installed to bottom of gearbox housing using the four 10mm x 1.5 x 25 cap screws (13) and lock washers (12). Use shim gaskets (10) and (11) to adjust output bearings to a rolling torque of 9 to 12 In-lbs.

**NOTE:** Be sure output gaskets (10 and 11) are in place. Apply grease to output seal (16) lip for easy installation.

8. Place ball bearing (21) at back of housing and press in socket using a round tube of the correct diameter and a hand press until fully seated.
9. Insert input shaft (5) part way through housing and slide gear (3) and retaining ring (6) over input shaft (5). Keep gear (3) and retaining ring (6) loose.
10. Insert input shaft (5) into roller bearing (21) until seated against each other.
11. Slide gear (3) forward and attach retaining ring (6) in groove closest to front of input shaft (5). Slide gear (3) back against retaining ring (6).
12. Check that the gear backlash is between 0.006" and 0.016". You should not have to adjust the backlash.
13. Slide gear spacer (7) and ball bearing (20) on input shaft (5) and secure with retaining rings (6) and (8).
14. Slide input seal (4) onto input shaft (5) and press into housing flush with front using a tube of correct diameter. Be careful not to damage seal lip.
15. Check gearbox housing for leaks by plugging all holes except one. Apply 4 psi compressed air and immerse the gearbox in water to verify that there are no leaks. Remove gearbox from water and dry off with compressed air. Add SAE 80W or 90W EP oil until it runs out of side level hole. Tighten all plugs.

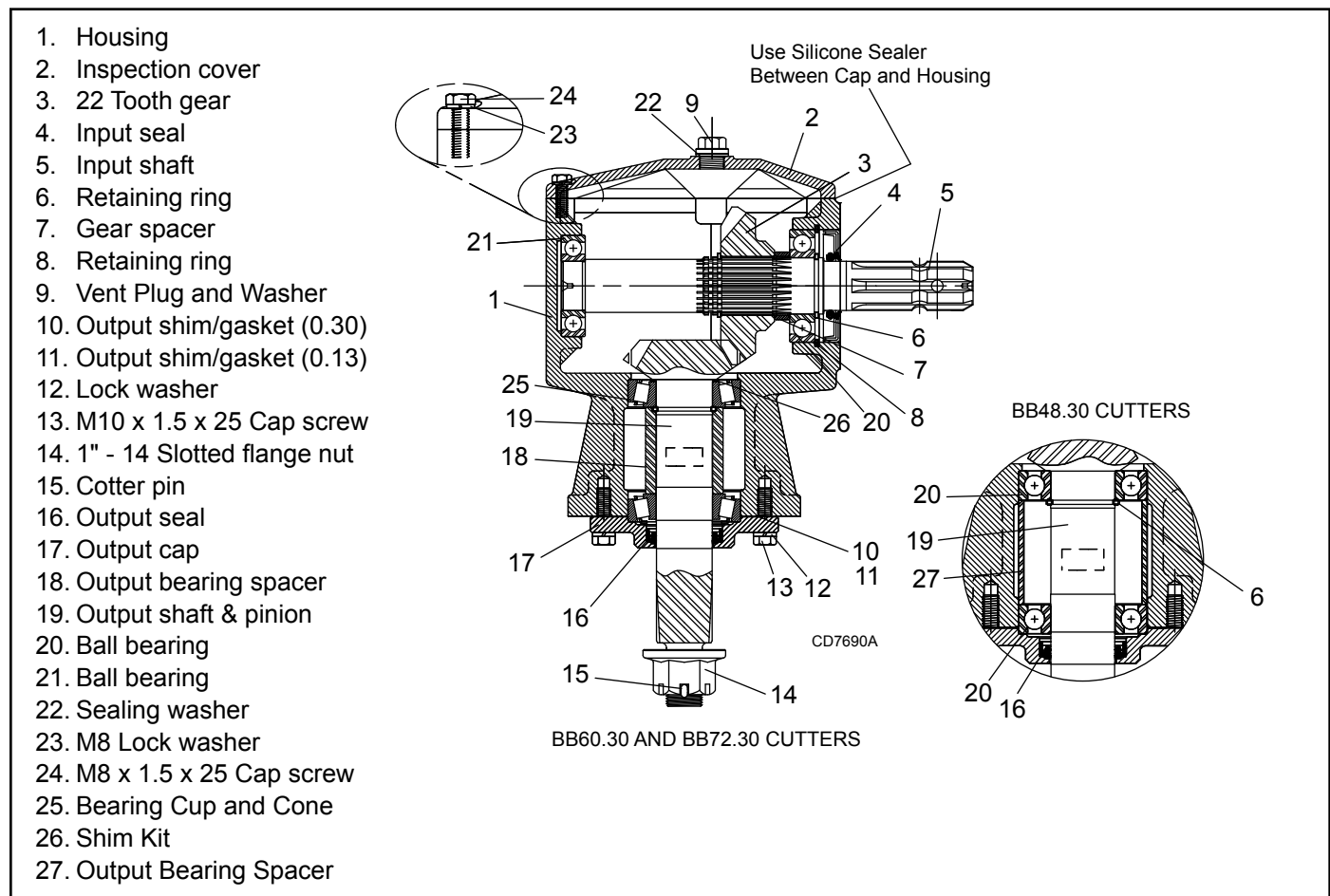

**Figure 17.** BB48.30, BB60.30, BB72.30 Gearbox Assembly

## **GEARBOX REPAIR - BB72.40, BB84.40**

Refer to Figure 18.

**NOTE:** Replacing gears, shafts, bearings, and seals may not be cost effective. Purchasing a complete gearbox may be more economical.

### **Remove Gearbox from Cutter**

1. Disconnect and remove the driveline from the gearbox.
2. Remove vent plug (3) and siphon gear lube from housing through this opening.
3. Remove cotter pin, washer, and nut from vertical shaft and remove crossbar. Hydraulic jack will not operate if tipped more than 90-degrees. Use care to prevent bending crossbar during removal. See page 28.
4. Remove the four bolts that attach gearbox to cutter and remove gearbox. Gearbox is heavy; do not attempt to move without mechanical assistance.

### **Disassemble Gearbox**

1. Remove 3/8" plug from side of gearbox and pour out gear oil.
2. Remove oil cap (24) (to be replaced).
3. Remove snap ring (9) and shim (5) from input shaft (11).
4. Support gearbox in hand press and push on input shaft (11) to remove bearing (23).
5. Remove top cover (4) from housing. Remove gear (6) from inside housing.
6. Remove oil seal (10) from front of housing (to be replaced).
7. Remove snap ring (9) and shim (5) from front of housing (1).
8. Remove input bearing (7) by using a punch and hammer from outside of housing.
9. Support housing in vise in a horizontal position.
10. The castle nut (21), cotter pin (8), and washer (20) are already removed with the stump jumper/ crossbar. Remove the protective screen (17) and seal (16).
11. Remove cotter pin (18), castle nut (12), and washer (25) from output shaft (19).
12. Remove output shaft (19) by using a punch and hammer and tap on top to drive down.
13. Remove gear (5) and shim (15) from inside housing.
14. Remove bearing (15) by using a punch and hammer from the top, outside the housing.
15. Support housing upside down (top cover surface) and remove bearing (15) by using a punch and hammer from the bottom side of the housing.

16. Inspect gears for broken teeth and wear. Some wear is normal and will show on loaded side. Forged gear surfaces are rough when new. Check that wear pattern is smooth.
17. Inspect vertical and horizontal shafts for grooves, nicks, or bumps in the areas where the seals seat. Resurface any damage with emery cloth.
18. Inspect housing and caps for cracks or other damage.

## **SEAL REPAIR - BB72.40, BB84.40**

Refer to Figure 18.

### **Vertical Shaft Seal Repair - BB72.40, BB84.40**

1. Disconnect and remove the driveline from the gearbox.
2. Remove vent plug (3) and siphon gear lube from housing through this opening.
3. Remove crossbar. Hydraulic jack will not operate if tipped more than 90-degrees. Use care to prevent bending crossbar during removal. See Crossbar Removal on page 28.
4. Remove vertical shaft seal (16). Replace with new seal (See Seal Installation on page 23.).

Vertical seal should be recessed in housing. Horizontal seal should be pressed flush with outside of housing.

**NOTE:** Distortion to seal cage or damage to seal lip will cause seal to leak.

5. Fill gearbox with SAE 80W or 90W gear lube until it runs out the level plug.
6. Remove and replace any seal damaged in installation.

### **Horizontal Shaft Seal Repair - BB72.40, BB84.40**

1. Disconnect and remove the driveline from the gearbox.
2. Remove vent plug (3) and siphon gear lube from housing through this opening.
3. If the leak occurred at either end of horizontal shaft (spindle gearbox), remove oil cap (24) and/or oil seal (10). For splitter gearbox (Figure 18) use oil seals (11) and (17). Replace with new one (refer to Seal Installation, page 23).
4. Fill gearbox with SAE 80W or 90W gear lube until it runs out the level plug.

### **Assemble Gearbox - BB72.40, BB84.40**

1. Clean housing, paying specific attention to areas where gaskets will be installed.
2. Wash housing and all components thoroughly. Select a clean area for gearbox assembly. Replace all seals, bearings, and gaskets. All parts must be clean and lightly oiled before reassembling.

**26 Dealer Service**

MAN1289  
(04/30/2024)

3. Insert output bearings (15) in the housing, using a round tube of the correct diameter and a hand press.
4. Slide output shaft (19) through both bearings (15) until it rests against bearing (6).
5. Slide shim (5) over output shaft (19).
6. Press gear (13) onto output shaft (19) and secure with washer (25), castle nut (12), and cotter pin (18).
7. Apply grease to lower seal lips (16) and press seal (16) over output shaft (19), using a tube of the correct diameter. Be sure not to damage the seal lip.

Press in housing so that seal is recessed. Install protective screen (17) and position it together with dual lip seal (16) by pressing it into position. Verify that snap ring is seated correctly.

8. Press bearing (7) into the housing, using a round tube of the correct diameter and a hand press. Secure with shim (5) and snap ring (9).
9. Secure snap ring (9) on input shaft (11) if not already secure.
10. Place gear (6) through top of housing and align gear (6) and gear (13) so that gear teeth are a match.
11. While holding gear (6) in place, slide input shaft (11) through gear (6) and bearing (7). Align splines on shaft (11) and gear (6).

12. Slide spacer (7) over input shaft (11) and press bearing onto input shaft (11), using a round tube of the correct diameter and a hand press.
13. Slide shim (5) over input shaft (11) and secure with snap ring (9).
14. Check input shaft end float by moving the input shaft (11) by hand. If end float is higher than 0.012", insert shim between input shaft (11) and rear bearing (7). Repeat until end float is less than 0.012". Check rotational torque by hand. The torque should be less than 2.2 lbs-inch.
15. Check that the gear backlash is between 0.006" and 0.016". You should not have to adjust the backlash.
16. Press in input oil seal (10), using tube of correct diameter. Be careful not to damage seal lip.
17. Press oil cap (24) on to cover the rear of housing, using a tube of the correct diameter.
18. Check gearbox housing for leaks by plugging all holes except one. Apply 4 psi compressed air and immerse the gearbox in water to verify that there are no leaks.
19. Remove gearbox from water and dry off with compressed air. Add SAE 80W or 90W EP oil until it runs out of side level hole. Tighten all plugs.

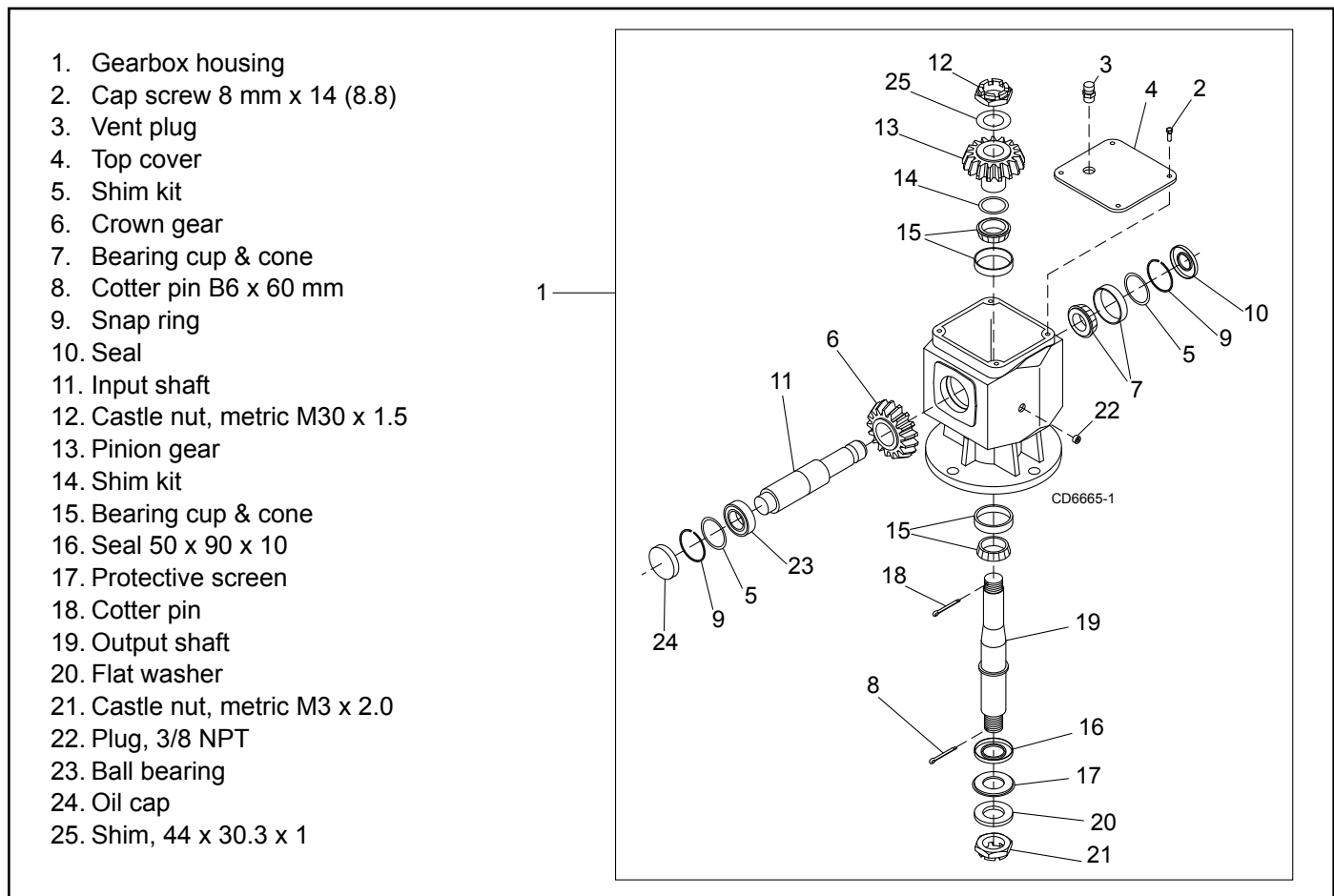

Figure 18. BB72.40, BB84.40 Gearbox Assembly

## Reinstall Gearbox - BB72.40, BB84.40

**NOTE:** Gearbox is heavy: do not attempt to move without mechanical assistance.

1. Set gearbox on cutter and fasten with bolts and nuts. Torque bolts to 300 lbs-ft.
2. Attach crossbar. Use care to prevent bending crossbar during removal. Hydraulic jack will not operate if tipped more than 90 degrees. See page 29.

## CROSSBAR REMOVAL

1. It is necessary to gain access to bottom side of cutter for crossbar removal. See OWNER SERVICE, page 18.

**NOTE:** You will need to use either the puller screw (item 6, Figure 20) or a small hydraulic jack to remove the crossbar.

2. To make crossbar removal easier, remove blades as shown in Figure 19.

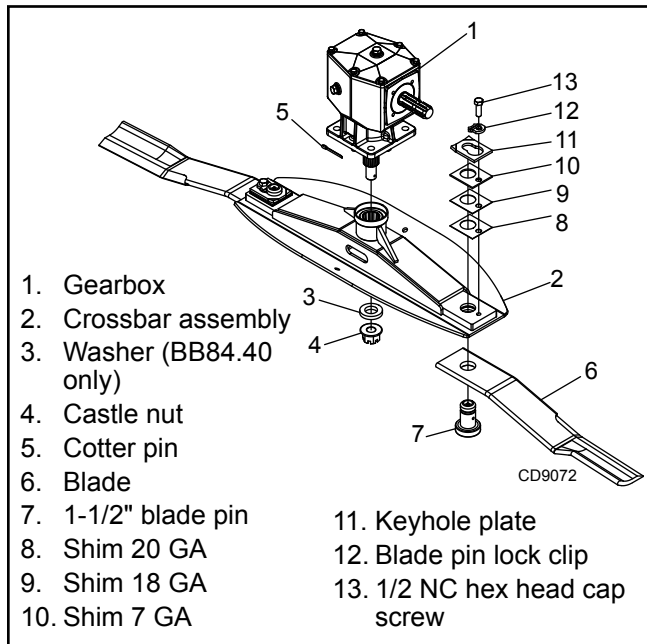
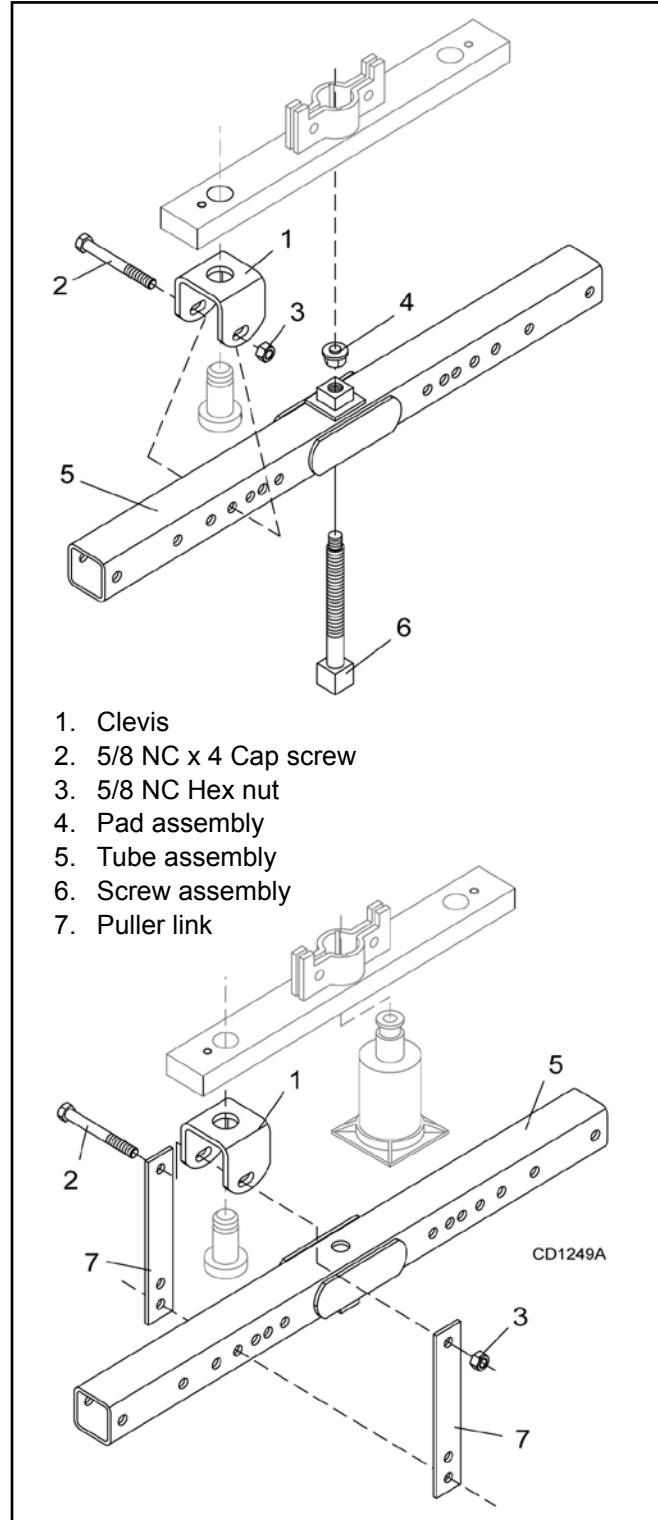

**Figure 19.** Blade Removal

3. Remove cotter pin, castle nut, and washer from bottom of crossbar, Figure 20.
4. Attach a clevis (1) to each end of crossbar, using blade pins, spacers, keyhole plates, and blade pin clips.
5. Position tube assembly (5) with threaded nut toward crossbar for puller screw removal or down for hydraulic jack removal.
6. For removal with puller screw, attach tube (5) to each clevis with bolts (2) and nuts (3). Place pad (4) in nut and thread puller screw (6) into nut from bottom. Tighten until pad is solid against gearbox shaft. For best results, strike head of puller screw with a hammer while tightening with a wrench.

7. For removal with a jack, attach tube to each clevis with puller links (7), bolts (2), and nuts (3). Place jack on tube with end of jack pressing against gearbox shaft. Slowly apply force with jack.

**NOTE:** Hydraulic jack will not operate if tipped more than 90-degrees. Use care to prevent bending crossbar during removal.



**Figure 20.** Crossbar Removal

## CROSSBAR INSTALLATION

1. Using emery cloth (220 or finer), remove surface rust, Loctite® and foreign material from hub, splined gearbox, vertical shaft, and crossbar as shown in Figure 21.

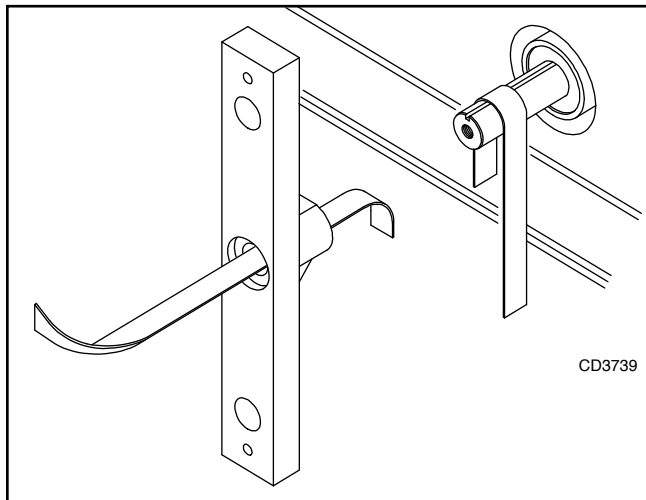

Figure 21.

2. Install crossbar (2) on splined shaft. Install washer, castle nut, and cotter pin. Torque nut:

BB48.30, BB60.30, BB72.30 . 200 lbs-ft

BB72.40, BB84.40 . . . . . 300 lbs-ft

3. Install the blades using existing hardware. Torque blade pin bolt to 85 lbs-ft.

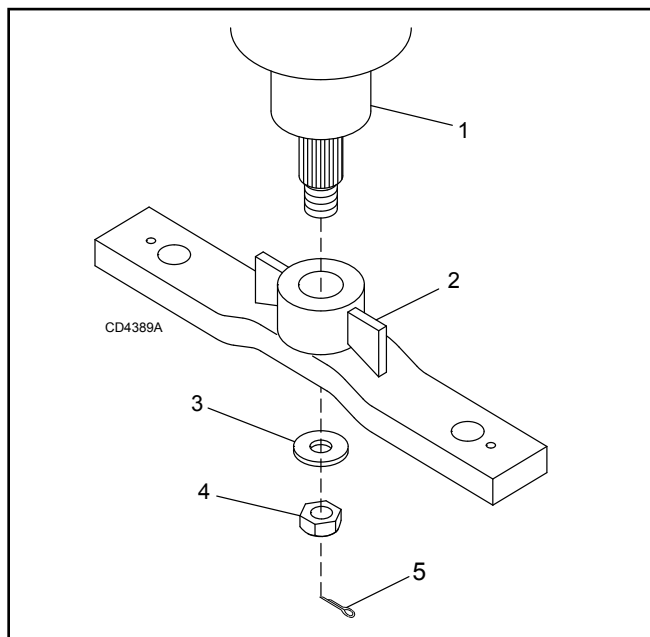

Figure 22.

## UNIVERSAL JOINT REPAIR

1. Yoke
2. Bearing cup
3. Retaining ring
4. Bearing cross

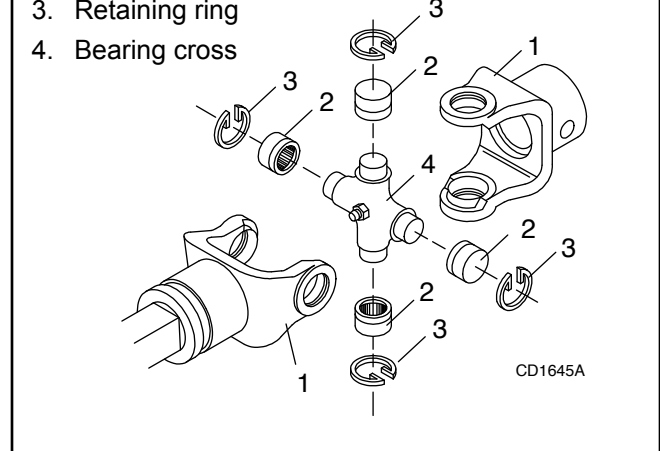

Figure 23. U-Joint Exploded View

### U-Joint Disassembly

1. Remove external snap rings from yokes in four locations as shown in Figure 24.

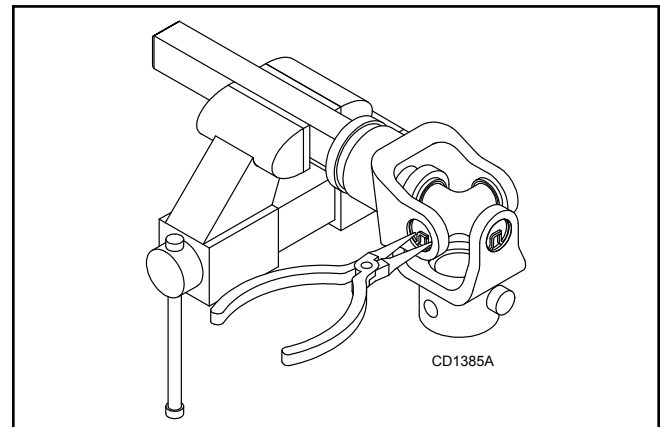

Figure 24. Remove Snap Ring

2. With snap rings removed, support drive in vise, hold yoke in hand and tap on yoke to drive cup up out of yoke. See Figure 25.

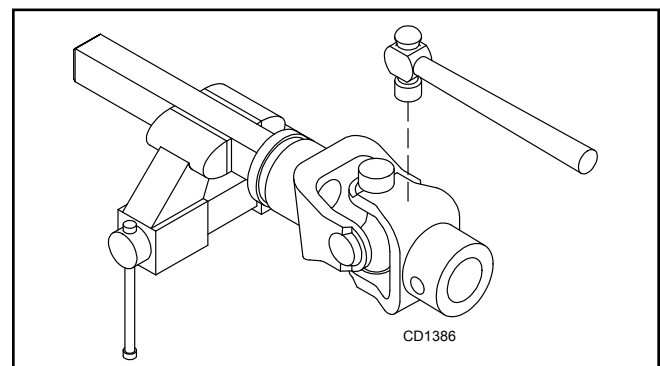
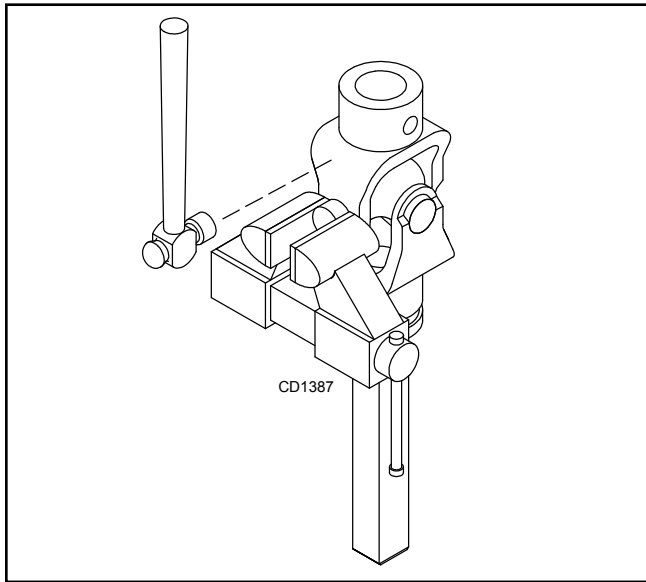

Figure 25. Remove Bearing Cups

3. Clamp cup in vise as shown in Figure 26 and tap on yoke to completely remove cup from yoke. Repeat Step 2 & Step 3 for opposite cup.



**Figure 26.** Remove Bearing Cups

4. Place universal cross in vise as shown in Figure 27 and tap on yoke to remove cup. Repeat Step 3 for final removal. Drive remaining cup out with a drift and hammer.

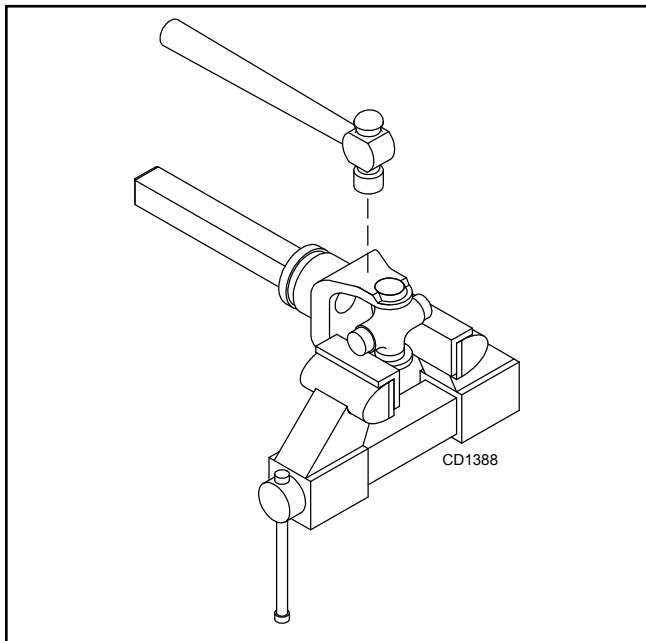

**Figure 27.** Remove Bearing Cups

## U-Joint Assembly

1. Place seals securely on bearing cups. Insert cup into yoke from outside and press in with hand pressure as far as possible. Insert journal cross into bearing cup with grease fitting away from shaft. Be careful not to disturb needle bearings. Insert another bearing cup directly across from first cup and press in as far as possible with hand pressure.
2. Trap cups in vise and apply pressure. Be sure journal cross is started into bearings and continue pressure with vise, squeezing in as far as possible. Tapping the yoke will help.
3. Seat cups by placing a drift or socket (slightly smaller than the cup) on cup and rap with a hammer. See Figure 28. Install snap ring and repeat on opposite cup.
4. Repeat Step 1 & Step 2 to install remaining cups in remaining yoke.
5. Move both yokes in all directions to check for free movement. If movement is restricted, rap on yokes sharply with a hammer to relieve any tension. Repeat until both yokes move in all directions without restriction.

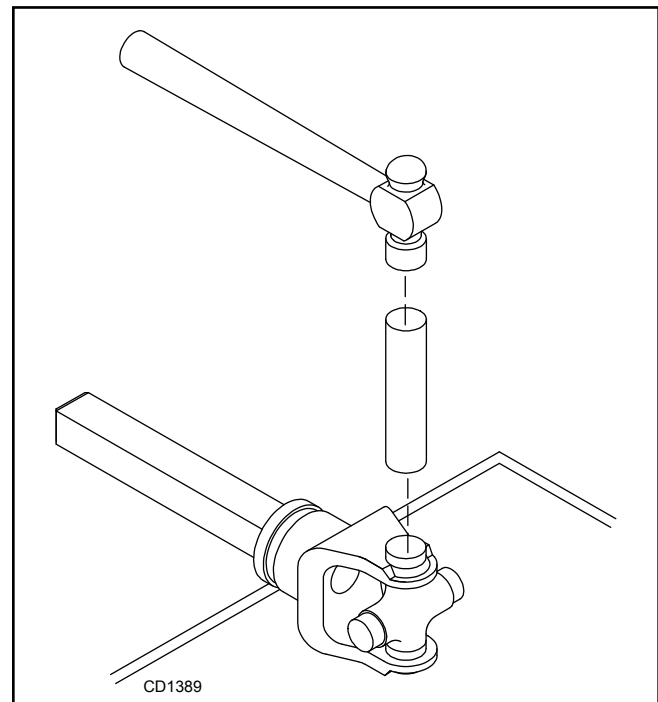

**Figure 28.** Install Bearing Cups

# ASSEMBLY

## DEALER SET-UP INSTRUCTIONS

Assembly of this cutter is the responsibility of the WOODS dealer. It should be delivered to the owner completely assembled, lubricated and adjusted for normal cutting conditions.

The cutter is shipped partially assembled and intended to be handled in the vertical position. Use appropriate lifting devices to move into horizontal position for assembly.

Assembly will be easier if aligned and loosely assembled before tightening hardware. Recommended torque values for hardware are located in the Bolt Torque Chart, page 53.

Complete Dealer Checklists, page 35 when you have completed the assembly.

### **! DANGER**

- Full chain shielding must be installed when operating in populated areas or other areas where thrown objects could injure people or damage property.
  - If this machine is not equipped with full chain shielding, operation must be stopped.

- This shielding is designed to reduce the risk of thrown objects. The mower deck and protective devices cannot prevent all objects from escaping the blade enclosure in every mowing condition. It is possible for objects to ricochet and escape, traveling as much as 300 feet (92 m).

### **! WARNING**

- Make sure attachment is properly secured, adjusted, and in good operating condition.

### **! CAUTION**

- Always wear relatively tight and belted clothing to avoid getting caught in moving parts. Wear sturdy, rough-soled work shoes and protective equipment for eyes, hair, hands, hearing, and head; and respirator or filter mask where appropriate.

## DISASSEMBLE SHIPPING UNIT

Remove wood blocks from front and bottom of cutter.

Remove all parts that are zip tied or wired to cutter.

**NOTE:** Driveline is banded to the inside of the cutter front frame.

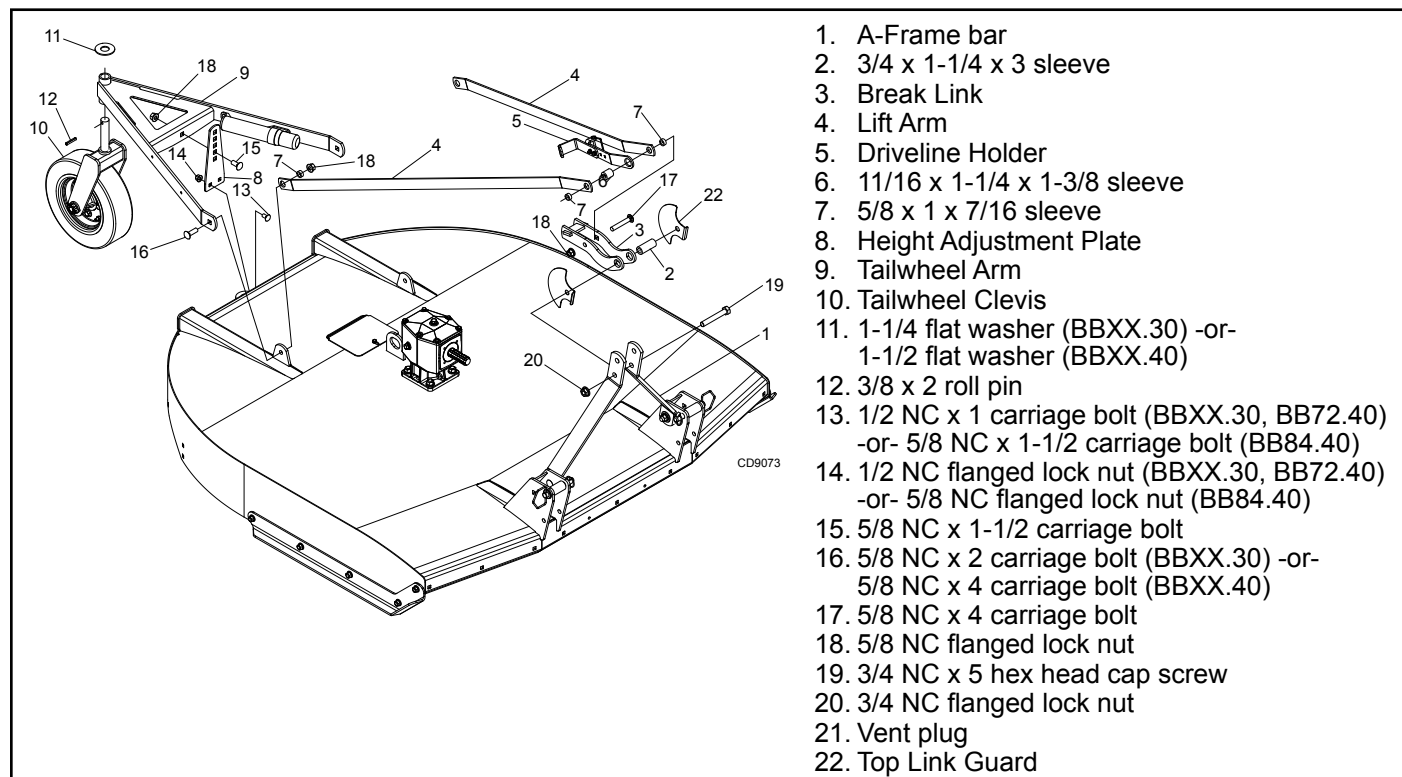

Figure 29. Cutter Assembly

MAN1289  
(04/30/2024)

Assembly 31

## ASSEMBLE CUTTER

Refer to Figure 29.

1. Attach Height Adjustment Plate (8) to rear frame of cutter deck using carriage bolts (13) and flanged lock nuts (14).
2. Attach Tailwheel Arm (9) and Lift Arms (4) to cutter at pivot lug using 5/8 NC carriage bolts (16), 5/8 x 1 x 7/16 sleeves (7), and 5/8 flanged lock nuts (18).
3. Select desired height adjustment holes and secure Tailwheel Arm (9) to Height Adjustment Plate (8) using 5/8 NC x 1-1/2 carriage bolts (15) and 5/8 NC flanged lock nuts (18).
4. Rotate A-Frame Bars (1) up and attach Break Link (3), Top Link Guards (22) and 3/4 x 1-1/4 x 3 sleeve (2) to lower hole in top of A-Frame Bars using 3/4 NC x 5 cap screw (19) and new 3/4 NC flanged lock nut (20).
5. Rotate Lift Arms (4) upward and attach to Break Link (3) and Driveline Holder (5) using 11/16 x 1-1/4 x 1-3/8 sleeve (6), 5/8 x 1 x 7/16 sleeves (7), 5/8 NC x 4 carriage bolt (17), and 5/8 NC flanged lock nut (18).
6. Secure Tailwheel Clevis (10) to Tailwheel (9) using flat washer (11) and spirol pin (12).
7. Remove solid plug from top of gearbox. Install vent plug or dipstick.

## INSTALL DRIVELINE

Refer to Figure 30.

**NOTE:** A new slip clutch, or one that has been in storage over the winter, may seize.

1. Before operating slip clutch, make sure it will slip. Refer to Slip Clutch Adjustment, page 20.
2. Position clutch shield (2) against gearbox (1). Secure with flange cap screws (6).
3. Install driveline (3) onto gearbox input shaft.

**For BB48.30 & BB60.30,** secure driveline (3A) to shaft of gearbox (1A) with Grade 8 cap screw (4A) and lock nut (5A).

**For BB72.30,** secure driveline (3B) to shaft of gearbox (1B) with tapered pin (4B) and lock nut (5B) supplied with driveline.

**NOTE:** Be sure to turn the taper of the pin toward the drive shaft. Fully seat the pin, install the nut and torque to 50 lbs-ft.

**For BB72.40, BB84.40,** secure the driveline (3C) to shaft of gearbox (1C) with two cap screws (4C) and lock nuts (5C).

4. Lubricate rear driveline half and install front driveline half.

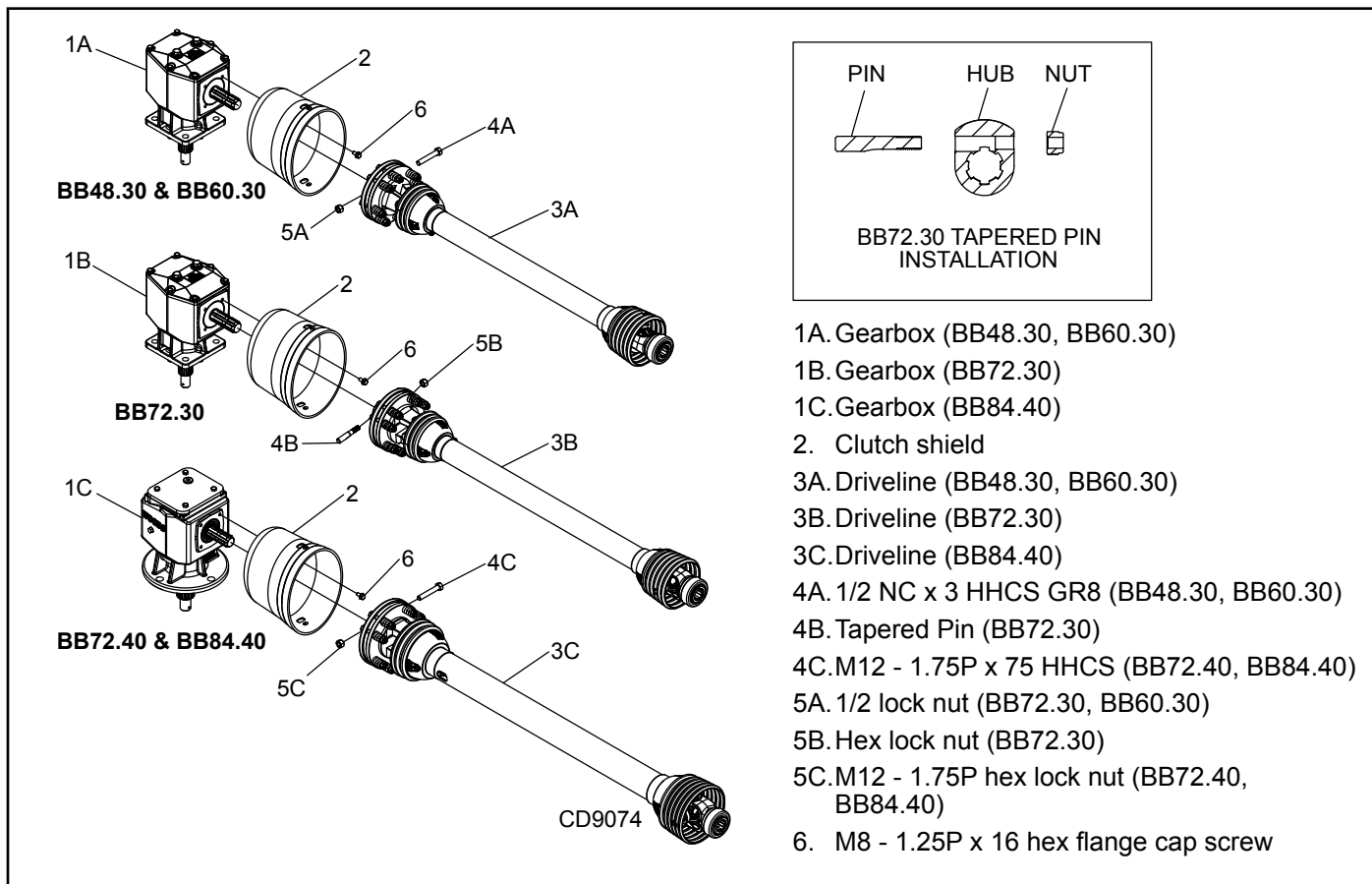

Figure 30. Driveline Installation



## INSTALL SAFETY SHIELDING

### **! DANGER**

- Full chain shielding must be installed when operating in populated areas or other areas where thrown objects could injure people or damage property.
  - If this machine is not equipped with full chain shielding, operation must be stopped.
  - This shielding is designed to reduce the risk of thrown objects. The mower deck and protective devices cannot prevent all objects from escaping the blade enclosure in every mowing condition. It is possible for objects to ricochet and escape, traveling as much as 300 feet (92 m).

### Front Belt Shielding

Refer to Figure 31.

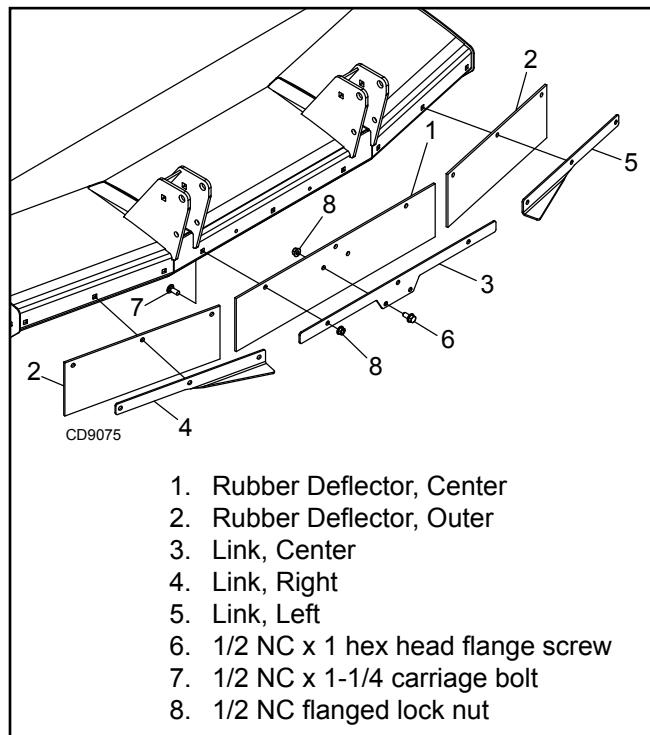
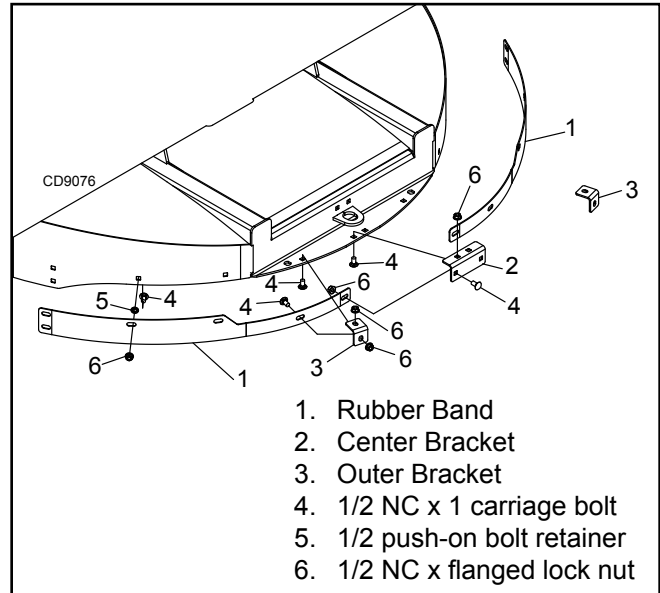

**Figure 31.** Front Belting Assembly

1. Attach center Rubber Deflector (1) to Link (3) with flanged cap screws (6) and flanged lock nuts (8).
2. Attach Rubber Deflectors (1) & (2) and Links (3), (4), & (5) to front of cutter using carriage bolts (7) and flanged lock nuts (8).

### Rear Steel Band

Refer to Figure 32.

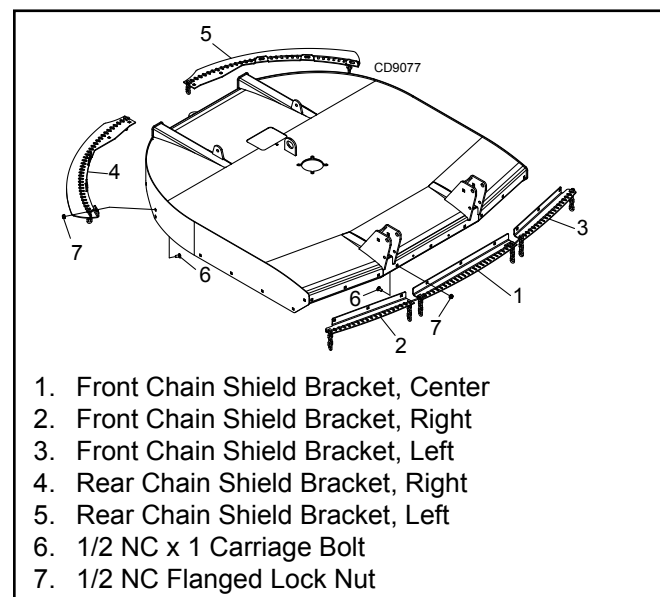

**Figure 32.** Rear Band Assembly

1. Install carriage bolts (4) into curved section of rear of cutter and secure with push-on bolt retainers (5).
2. Attach one Rear Band (1) to carriage bolts on rear of cutter starting at double slot end and secure with flanged lock nuts (6). Repeat for other side.
3. Attach Rear Bands (1) to horizontal ledge of rear frame with Outer Brackets (3), carriage bolts (4) and flanged lock nuts (6).
4. Secure inner ends of Rear Bands (1) to center of cutter rear frame with Center Bracket (2), carriage bolts (4) and flanged lock nuts (6).

### Front and Rear Chain Shielding

Refer to Figure 33.

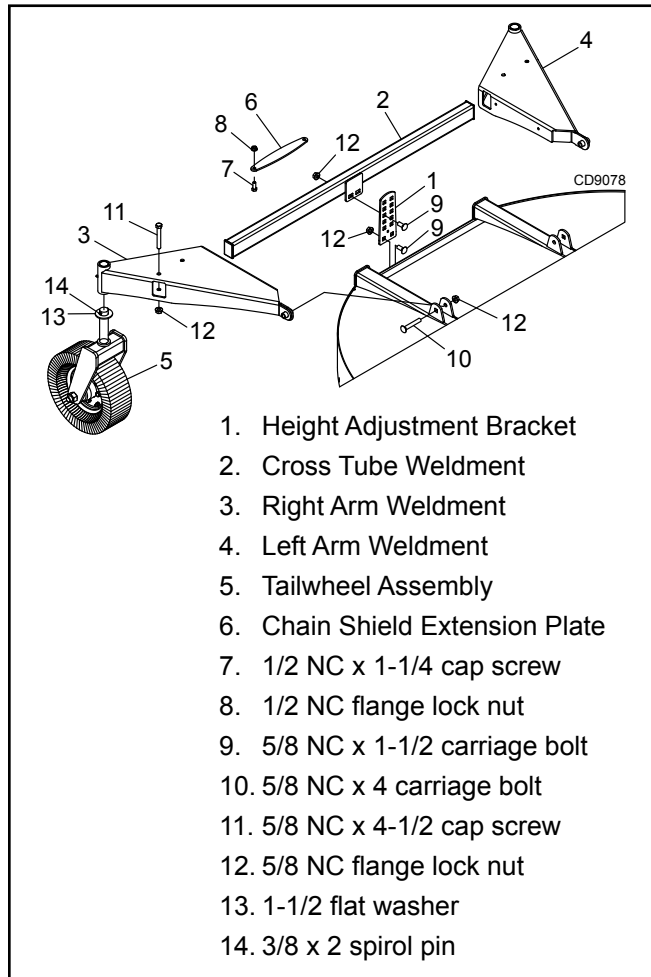

**Figure 33.** Chain Shield Assembly

1. Install Front Center (1), Right (2), and Left (3) Chain Shield Brackets to front frame of cutter using carriage bolts (6) and flanged lock nuts (7).
2. Install Rear Right (4) and Left (5) Chain Shield Brackets to rear of cutter using carriage bolts (6) and flanged lock nuts (7).

## **INSTALL DUAL TAILWHEEL - BB84.40D ONLY**

Refer to Figure 34.



**Figure 34.** Dual Tailwheel Assembly

1. Install Height Adjustment Bracket (1) to rear of cutter using 5/8 NC x 1-1/2 carriage bolts (9) and 5/8 NC flanged lock nuts (12).
2. Slide Right Arm Weldment (3) and Left Arm Weldment (4) over Cross Tube Weldment (2). Orient as shown. Do not install hardware at this time.
3. Place Arm and Cross Tube Assembly onto rear of deck aligning pivot tubes of arms between lugs on deck. The center bracket on the Cross Tube (2) should be in line with the Height Adjustment Bracket (1).

4. Secure pivots of Arm Weldments (3 & 4) to deck using 5/8 NC x 4 carriage bolts (10) and 5/8 NC flanged lock nuts (12).
5. Clamp Arms (3 & 4) to Cross Tube (2) using 5/8 NC x 4-1/2 cap screws (11) and 5/8 NC flanged lock nuts (12).
6. Install Tailwheel Assemblies (5) into Right (3) and Left (4) Arms. Secure with 1-1/2 flat washer (13) and 3/8 x 2 spirol pin (14).
7. For models with rear chain shield: Install Chain Shield Extension Plate (6) on top of Rear Chain Shield Brackets and secure with 1/2 NC x 1-1/4 cap screws (7) and 1/2 NC flanged lock nuts (8).

**For models with rear band:** Discard items 6, 7, & 8.

## **INSTALL CHECK CHAIN (OPTIONAL)**

Check chains are used to carry the front of cutter at a set height.

1. Thread check chains (2) through check chain bracket (1).
2. Attach lower end of check chain (2) to mast plate with bolt (5), washer (6), and nut (7).
3. Attach keyhole brackets (1) to each side of tractor top link bracket with bolt (3) and nut (4).
4. Insert check chains through keyhole brackets and set cutter height.

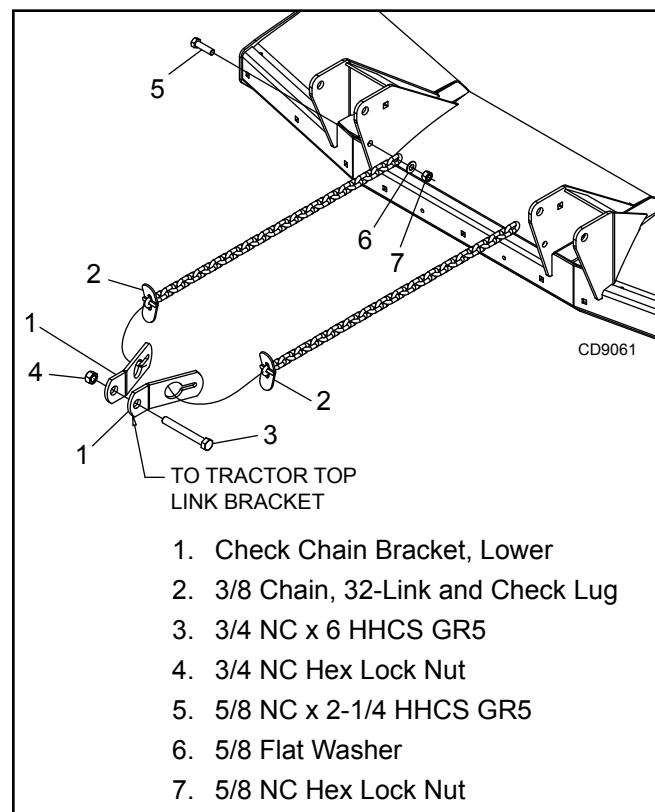

**Figure 35.** Check Chain Installation

# DEALER CHECKLISTS

## DEALER PRE-DELIVERY CHECKLIST

### (DEALER'S RESPONSIBILITY)

Inspect cutter thoroughly after assembly to make sure it is set up properly before delivering it to the customer. The following checklist is a reminder of points to inspect. Check off each item as it is found satisfactory, corrections are made, or services are performed.

- \_\_\_\_\_ Check all bolts to be sure they are properly torqued.
- \_\_\_\_\_ Check that all cotter pins are properly installed and secured.
- \_\_\_\_\_ Check that PTO shaft is properly installed.
- \_\_\_\_\_ Check that gearbox is properly serviced and seals are not leaking.
- \_\_\_\_\_ Check and grease all lubrication points as identified in, Lubrication Information, page 18.
- \_\_\_\_\_ Check that blades have been properly installed.

## DELIVERY CHECKLIST

### (DEALER'S RESPONSIBILITY)

- \_\_\_\_\_ Show customer how to make adjustments. Describe the options available for this cutter and explain their purpose.
- \_\_\_\_\_ Explain importance of lubrication to customer and point out lubrication points on cutter.
- \_\_\_\_\_ Present Operator's Manual and request that customer and all operators read it before operating equipment. Point out the manual safety rules, explain their meanings and emphasize the increased safety hazards that exist when safety rules are not followed.
- \_\_\_\_\_ Point out all guards and shielding. Explain their importance and the safety hazards that exist when not kept in place and in good condition.
- \_\_\_\_\_ For mounted units, add wheel weights, ballast in front tires, and/or front tractor weight to enhance front end stability. A minimum 20% of tractor and equipment gross weight must be on front tractor wheels. When adding weight to attain 20% of tractor and equipment weight on front tractor wheels, you must not exceed the ROPS weight certification. Weigh the tractor and equipment. Do not estimate!
- \_\_\_\_\_ Explain to customer that when equipment is transported on a road or highway, safety devices should be used to give adequate warning to operators of other vehicles.

# NOTES

## **36** *Dealer Checklists*

MAN1289  
(04/30/2024)



# BRUSHBULL™ Rotary Cutters

  
**BB48.30**  
**BB60.30**  
**BB72.30**  
**BB72.40**  
**BB84.40**

BRUSHBULL™ MAIN ASSEMBLY . . . . .	38 - 39
BRUSHBULL™ HITCH ASSEMBLY . . . . .	40
GEARBOX ASSEMBLY (BB48.30, BB60.30, BB72.30) . . . . .	41 - 42
GEARBOX ASSEMBLY (BB72.40, BB84.40) . . . . .	43 - 44
DRIVELINES:	
BB48.30 & BB60.30 DRIVELINE ASSEMBLY . . . . .	45 - 46
BB72.30 DRIVELINE ASSEMBLY . . . . .	47
BB72.30 DRIVELINE ASSEMBLY . . . . .	48
BB72.40 & BB84.40 DRIVELINE ASSEMBLY . . . . .	49
TAILWHEEL ASSEMBLY . . . . .	50
FRONT RUBBER BELTING & REAR BAND . . . . .	51
FRONT & REAR CHAIN SHIELDING . . . . .	51
DUAL TAILWHEEL ASSEMBLY (OPTIONAL) . . . . .	52
CHECK CHAIN ASSEMBLY (OPTIONAL) . . . . .	52

# BRUSHBULL MAIN FRAME ASSEMBLY

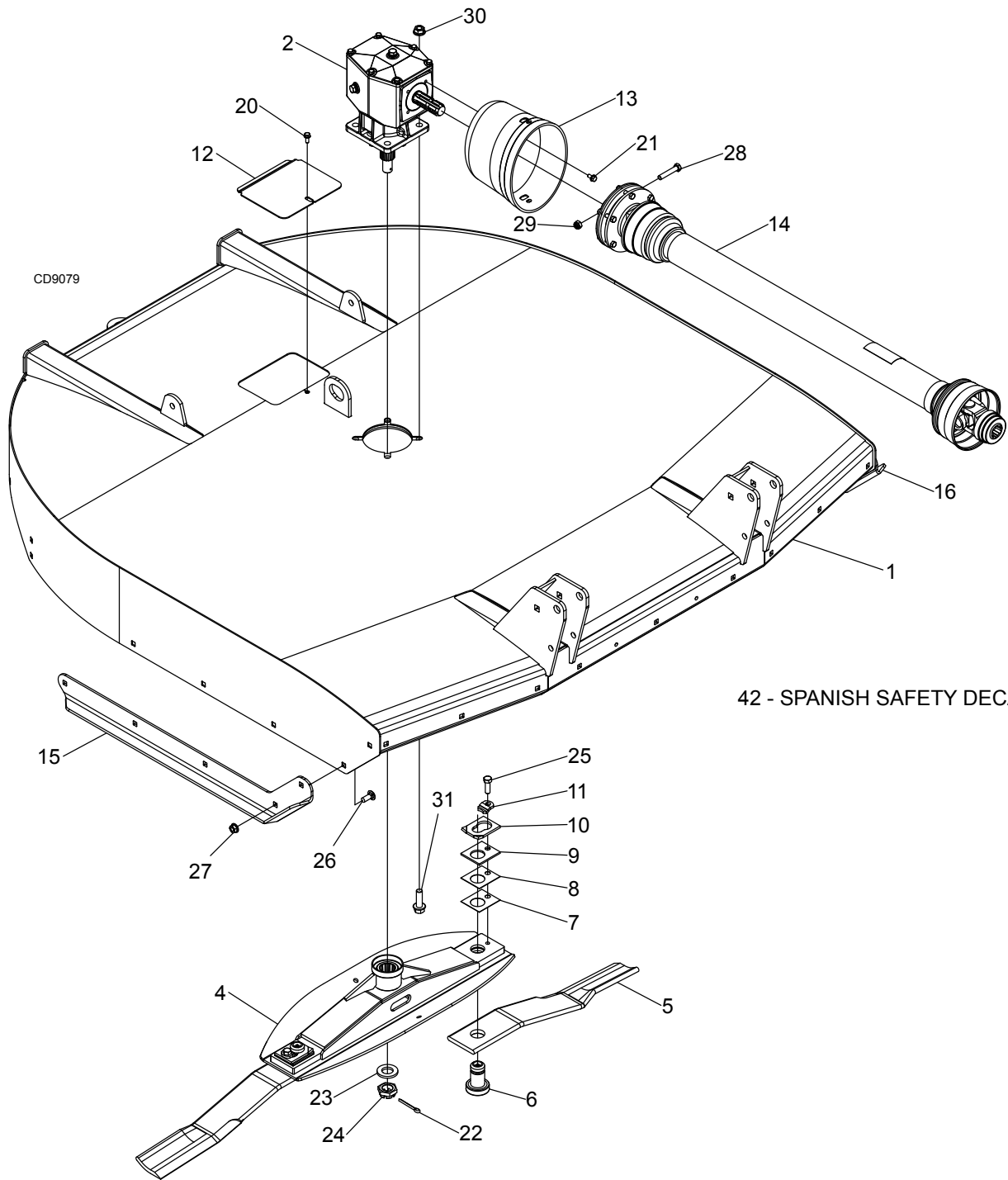

42 - SPANISH SAFETY DECAL SET

**38** Parts

MAN1289  
(04/30/2024)

## BRUSHBULL MAIN FRAME ASSEMBLY

REF	PART	QTY	DESCRIPTION	REF	PART	QTY	DESCRIPTION
1	----	1	Deck weldment	22	64803	1 *	3/16 x 2 cotter pin
2	----	1	Gearbox - BB48.30, BB60.30, BB72.30 (see pages 41 - 42)	23	610385RP	1	1.25 x 2.23 x .375 washer - BB72.40, BB84.40
	----	1	Gearbox - BB72.40, BB84.40 (see pages 43 - 44)	24	1018331	1	1" - 14 slotted flange nut - BB48.30, BB60.30, BB72.30
4	610285RP	1	Crossbar - BB48.30, BB60.30		W39323	1	M30 x 2.0P castle nut - BB72.40, BB84.40
	608159RP	1	Crossbar - BB72.30	25	3379	2 *	1/2 NC x 1-1/2 HHCS GR5
	640381RP	1	Crossbar - BB72.40	26	14406	12 *	1/2 NC x 1 carriage bolt
	610376RP	1	Crossbar - BB84.40	27	11900	12 *	1/2 NC flanged lock nut
5	57099KT	1	Blade 1/2 x 4 x 19.0 CCW - BB48.30	28	1024632	1	1/2 NC x 3 HHCS GR8 - BB48.30, BB60.30
	19160KT	1	Blade 1/2 x 4 x 25.0 CCW - BB60.30		1044091	1	Tapered pin (includes nut 29) - BB72.30
	1043260KT	1	Blade 1/2 x 4 x 25.0 CCW - BB72.30, BB72.40		1045118	2 *	M12-1.75P X 75 HHCS Grade 5 - BB72.40, BB84.40
	610303KT	1	Blade 1/2 x 4 x 31.0 CCW - BB84.40	29	765	1 *	1/2 NC lock nut - BB48.30, BB60.30
6	608126RP	2	Blade pin		58549	2	M12 - 1.75P hex lock nut - BB72.40, BB84.40
7	13946RP	2	20 GA 1-1/2 blade pin shim	30	609225	4	5/8 NC Gr. G flange lock nut - BB48.30, BB60.30, BB72.30
8	10520RP	2	18 GA 1-1/2 blade pin shim		1045611	4	3/4 NC, Gr. F flange lock nut - BB72.40, BB84.40
9	5523RP	2	7 GA 1-1/2 blade pin shim	31	1038890	4	5/8 NC x 2, Gr. 5 hex flanged screw, GR8 - BB48.30, BB60.30, BB72.30
10	32603	2	Keyhole plate special		603845	4	3/4 NC x 2-1/4, Gr. 5 hex flanged screw - BB72.40, BB84.40 GR5
11	32604RP	2	Blade pin lock clip	42	610134	1	Spanish safety decal set
12	57050RP	1	Blade access cover	NS	610304	1	Decal, Model BB48.30
13	1002048	1	Clutch shield	NS	610305	1	Decal, Model BB60.30
14	----	1	Slip clutch driveline (see pages 45 - 49)	NS	610306	1	Decal, Model BB72.30
15	610288RP	1	Skid shoe, right - BB48.30	NS	640386	1	Decal, Model BB72.40
	610290RP	1	Skid shoe, right - BB60.30	NS	610307	1	Decal, Model BB84.40
	608146RP	1	Skid shoe, right - BB72.30, BB72.40			*	Standard hardware, obtain locally
	610382RP	1	Skid shoe, right - BB84.40			NS	Not Shown
16	610289RP	1	Skid shoe, left - BB48.30				
	610291RP	1	Skid shoe, left - BB60.30				
	608147RP	1	Skid shoe, left - BB72.30, BB72.40				
	610383RP	1	Skid shoe, left - BB84.40				
20	71851	1	.312 NC x 3/4 HFS				
21	1041071	4	M8 - 1.25P x 16 mm HFS, CL8.8				

**NOTE:** For safety decals, see pages 10 and 11. Order decals separately.

# BRUSHBULL HITCH ASSEMBLY

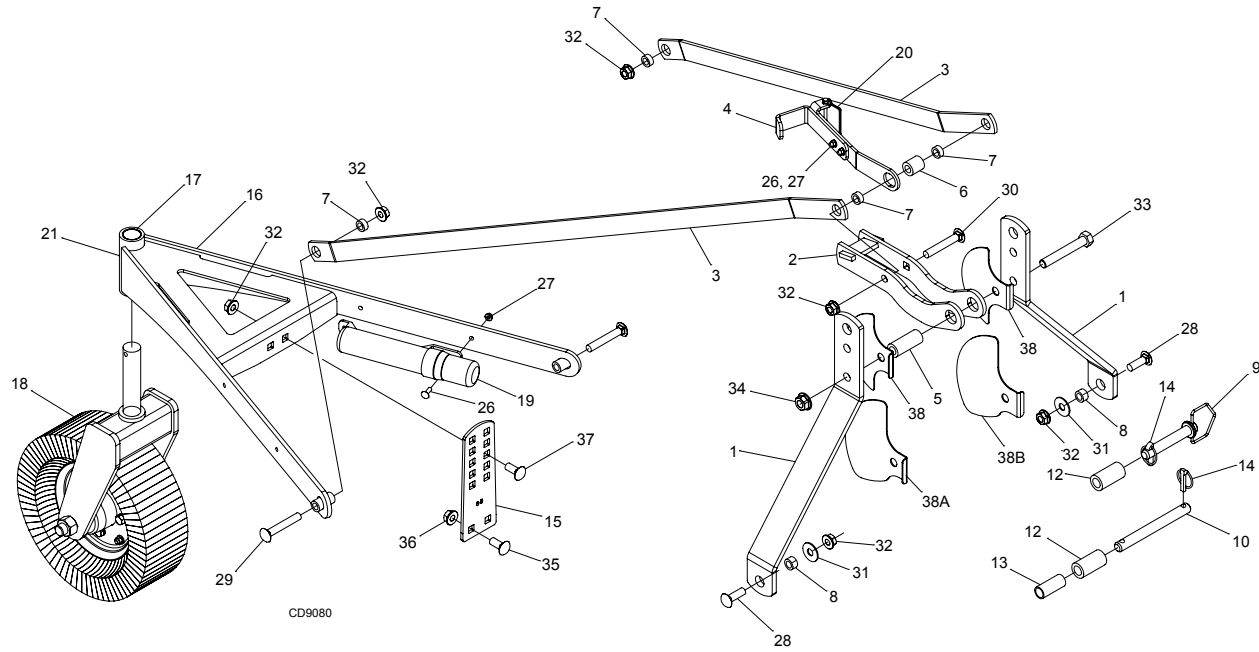

REF	PART	QTY	DESCRIPTION	REF	PART	QTY	DESCRIPTION
1	608128RP	2	A-frame bar - BB48.30, BB60.30, BB72.30	19	1026530	1	Manual tube
	610174RP	2	A-frame bar - BB72.40, BB84.40	20	S07095300	1	1/4 x 2-1/2 lock pin
2	608155RP	1	Break link - BB48.30, BB60.30, BB72.30, BB72.40	21	12296	1 *	1/4-28 straight grease fitting, 15/32 long
	610189RP	1	Break link - BB84.40	26	51243	4	5/16 NC x 1 carriage bolt
3	610292RP	2	Lift arm - BB48.30	27	W73163	4 *	5/16 NC flange nut
	610293RP	2	Lift arm - BB60.30	28	2855	2 *	5/8 NC x 2 carriage bolt
	608137RP	2	Lift arm - BB72.30, BB72.40	29	2855	2 *	5/8 NC x 2 carriage bolt - BB48.30, BB60.30, BB72.30
	610375RP	2	Lift arm - BB84.40		W301147	2	5/8 NC x 4 carriage bolt - BB72.40, BB84.40
4	610327RP	1	Driveline holder	30	W301147	1	5/8 NC x 4 carriage bolt
5	27140	1	3/4 x 1-1/4 x 3 sleeve	31	692	2 *	5/8 flat washer
6	609222	1	11/16 x 1-1/4 x 1-3/8 sleeve	32	609225	9	5/8 NC, Gr. G flange lock nut
7	484	4	5/8 x 1 x 7/16 sleeve	33	2376	1 *	3/4 NC x 5 HHCS
8	1791	2	5/8 x 1 x 9/16 sleeve	34	1045611	1	3/4 NC, Gr. F flange lock nut
9	SU105	2	Cat 1 drawbar pin (includes 14) - BB48.30, BB60.30, BB72.30	35	14406	2 *	1/2 NC x 1 carriage bolt - BB48.30, BB60.30, BB72.30, BB72.40
10	HBL233	2	7/8 x 6-15/16 headless pin - BB72.40, BB84.40		5607	2 *	5/8 NC x 1-1/2 carriage bolt - BB84.40
12	1002012	2	15/16 x 1-7/16 x 2-3/4 sleeve	36	11900	2 *	1/2 NC flange lock nut - BB48.30, BB60.30, BB72.30, BB72.40
13	56598	2	7/8 x 1-1/8 x 2-5/8 sleeve - BB72.40, BB84.40		609225	2	5/8 NC flange lock nut - BB84.40
14	43627	4	Lynch pin	37	5607	2 *	5/8 NC x 1-1/2 carriage bolt
15	608127RP	1	Height adjustment plate - BB48.30, BB60.30, BB72.30	38	640404RP	2	Guard, Top Link - BB48.30, BB60.30, BB72.30
	640385RP	1	Height adjustment plate - BB72.40	38A	639758RP	1	Guard, Top Link RH - BB72.40, BB84.40
	610386RP	1	Height adjustment plate - BB84.40	38B	639759RP	1	Guard, Top Link LH - BB72.40, BB84.40
16	608154RP	1	Wheel arm - BB48.30, BB60.30, BB72.30			*	Standard hardware, obtain locally
	610170RP	1	Wheel arm - BB72.40, BB84.40			HHCS	Hex Head Cap Screw
17	W11011	2	1-1/2 x 1-5/8 x 1-1/2 bronze bushing - BB72.40, BB84.40				
18	----	1	Tailwheel assembly - BB48.30, BB60.30, BB72.30 (see page 48)				
	----	1	Tailwheel assembly - BB72.40, BB84.40 (see page 48)				

**40 Parts**

MAN1289  
(04/30/2024)



# GEARBOX ASSEMBLY - BB48.30, BB60.30, BB72.30

(USED ON MACHINES BUILT SEPTEMBER 2020 AND LATER)

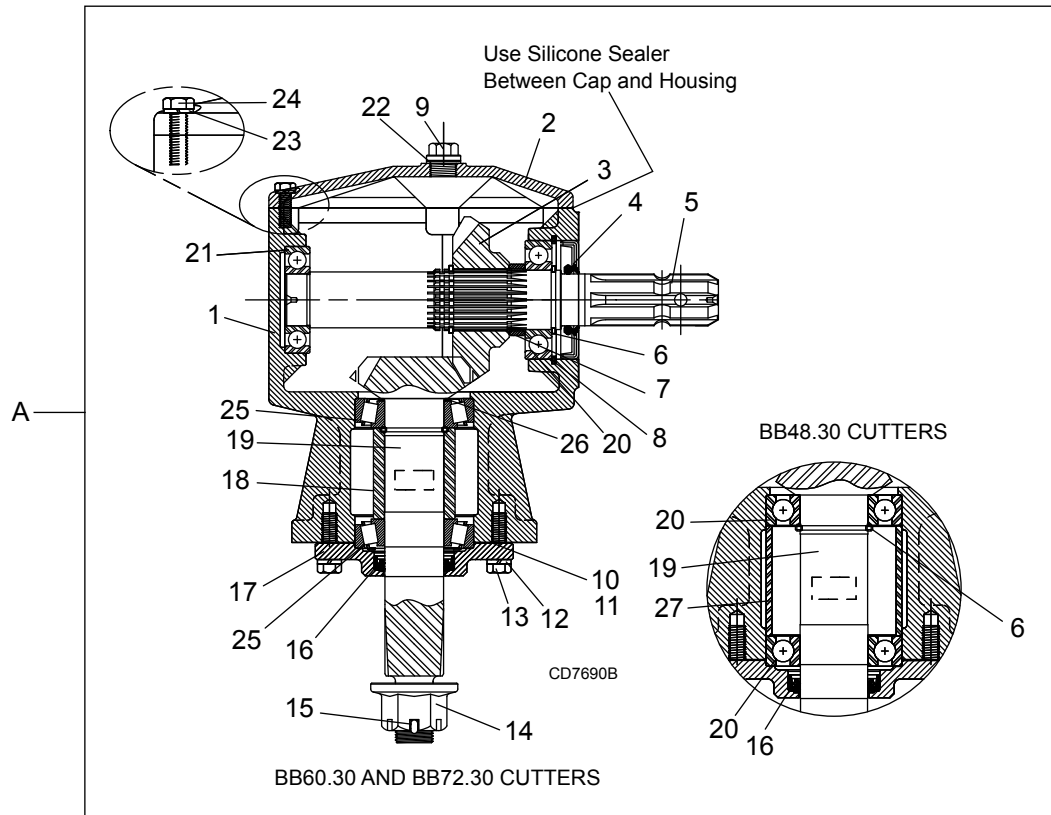

REF	PART	QTY	DESCRIPTION	REF	PART	QTY	DESCRIPTION
A	617198RP	1	Complete gearbox assembly - (splined input shaft) - BB48.30	13	----	4	M10 x 1.5 x 25 cap screw
A	617196RP	1	Complete gearbox assembly - (splined input shaft) BB60.30	14	1018331	1	1" - 14 Slotted flange nut
A	617195RP	1	Complete gearbox assembly - (splined input shaft) BB72.30	15	----	1	Cotter pin
1	----	1	Housing	16	614308	1	Output seal
2	1019632	1	Inspection cover	17	1038357	1	Output cap
3	----	1	Input gear	18	----	1	Output bearing spacer
4	1018327	1	Input seal	19	----	1	Output shaft and pinion
5	----	1	Input shaft	20	1018326	3	Ball bearing
6	----	1	Retaining ring	21	1018325	1	Ball bearing
7	----	1	Gear spacer	22	----	2	Sealing washer w/ plug
8	----	1	Retaining ring	23	----	6	Lock washer
9	1011780RP	1	Vent Plug and washer	24	----	6	M8 x 1.5 x 25 cap screw
	614309	1	Dipstick (optional)	25	57478	2	Bearing cup and cone
10	1018329	A/R	Output gasket (0.30)	26	1032963	1	Shim kit
11	1018330	A/R	Output gasket (0.13)	27	----	1	Output bearing spacer
12	----	4	Lock washer			A/R	As required
						----	Not serviced separately

# GEARBOX ASSEMBLY - BB48.30, BB60.30, BB72.30

(USED ON MACHINES BUILT PRIOR TO SEPTEMBER 2020)

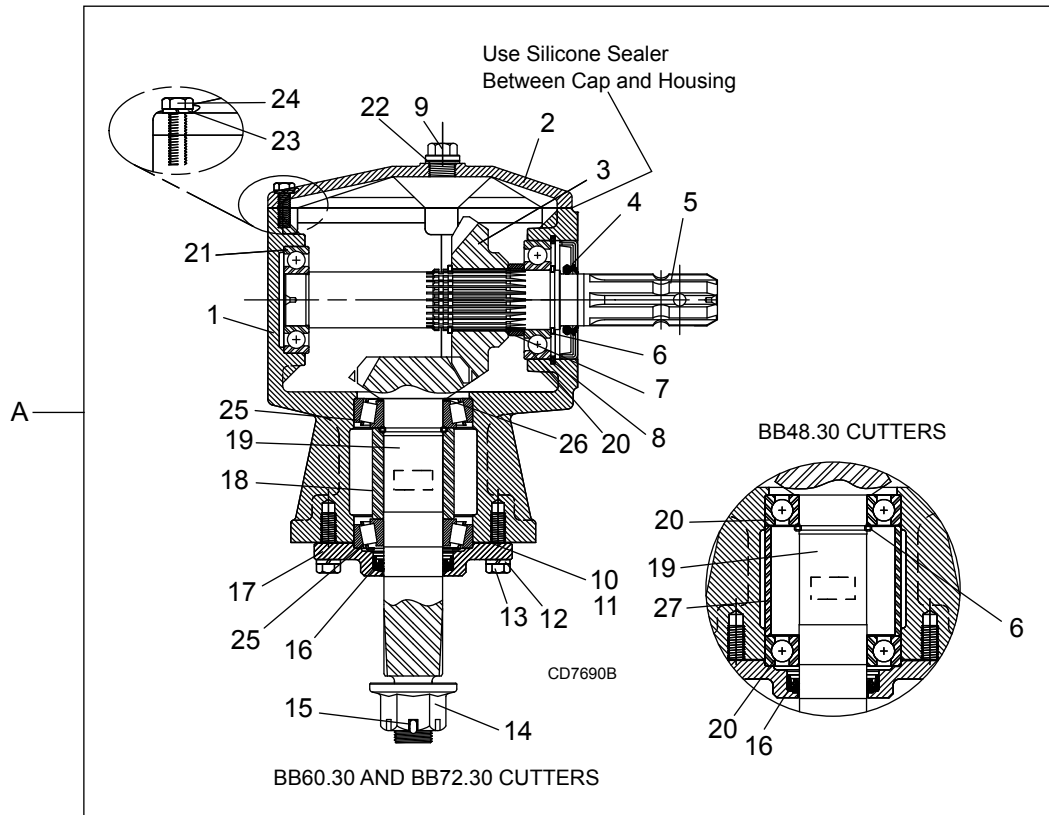

REF	PART	QTY	DESCRIPTION	REF	PART	QTY	DESCRIPTION
A	1032587	1	Complete gearbox assembly - (smooth input shaft) - BB48.30	14	1018331	1	1" - 14 Slotted flange nut
A	1032588	1	Complete gearbox assembly - (smooth input shaft) BB60.30	15	----	1	Cotter pin
A	1032585	1	Complete gearbox assembly - (splined input shaft) BB72.30	16	1018328	1	Output seal
1	----	1	Housing	17	1038357	1	Output cap
2	1019632	1	Inspection cover	18	----	1	Output bearing spacer
3	----	1	Input gear	19	----	1	Output shaft and pinion
4	1018327	1	Input seal	20	1018326	3	Ball bearing
5	----	1	Input shaft	21	1018325	1	Ball bearing
6	----	1	Retaining ring	22	----	2	Sealing washer w/ plug
7	----	1	Gear spacer	23	----	6	Lock washer
8	----	1	Retaining ring	24	----	6	M8 x 1.5 x 25 cap screw
9	1011780RP	1	Vent Plug and washer	25	57478	2	Bearing cup and cone
10	1018329	A/R	Output gasket (0.30)	26	1032963	1	Shim kit
11	1018330	A/R	Output gasket (0.13)	27	----	1	Output bearing spacer
12	----	4	Lock washer		A/R		As required
13	----	4	M10 x 1.5 x 25 cap screw		----		Not serviced separately

## 42 Parts

MAN1289  
(04/30/2024)

# BB72.40 & BB84.40 GEARBOX ASSEMBLY

(USED ON MACHINES BUILT SEPTEMBER 2020 AND LATER)

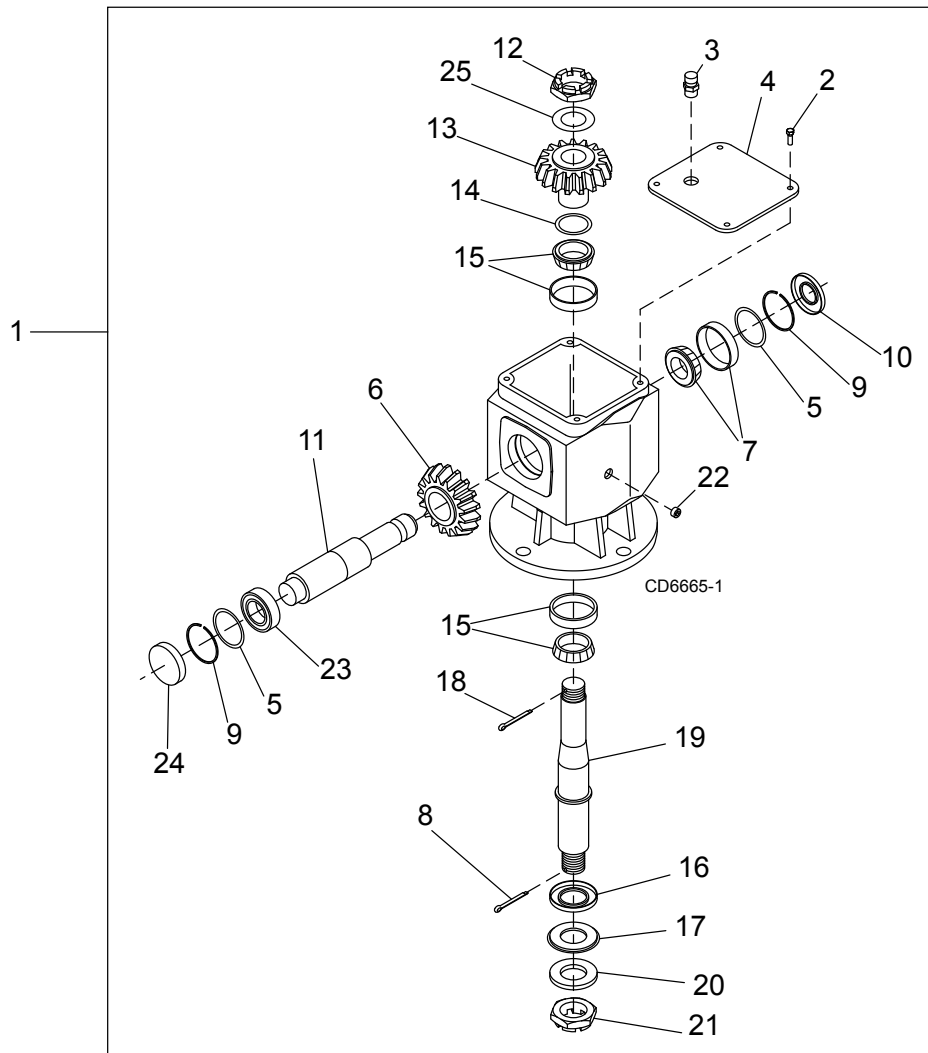

REF	PART	QTY	DESCRIPTION	REF	PART	QTY	DESCRIPTION
1	617158RP	1	Complete gearbox - BB72.40	15	39263	2	Bearing, cup & cone
	617154RP	1	Complete gearbox - BB84.40	16	1045873	1	Seal, 50 x 90 x 10
2	----	4 *	M8-1.25P x 14 mm HHCS	17	57338	1	Screen protection
3	57076	1	1/2 Vent plug	18	----	1 *	Cotter pin, B4 x 55 mm
	614342	1	Dipstick (optional)	19	----	1	Output shaft
4	----	1	Cover	20	610385RP	1	Flat washer, 31 x 56 x 4
5	57328	1	Shim kit, 60.3 x 71.7	21	W39323	1	M30-2.0P castle nut
6	----	1	Crown gear	22	27326	1	3/8 NPT Solid plug
7	57462	1	Bearing, cup & cone	23	20890	1	Ball bearing
8	----	1 *	Cotter pin, B6 x 60 mm	24	57374	1	Oil cap
9	57466	2	Snap ring	25	57094	1	Shim, 44 x 30.3 x 1
10	57463	1	Seal, 35 x 72 x 10		----		Not Serviced Separately
11	----	1	Input shaft, 1-3/8 6 spline		HHCS		Hex Head Cap Screw
12	----	1 *	M30-1.5P Castle nut		*		Standard hardware, obtain locally
13	----	1	Pinion gear				
14	57471	1	Shim kit, 50.3 x 70.3				

# BB84.40 SPINDLE GEARBOX ASSEMBLY

(USED ON MACHINES BUILT PRIOR TO SEPTEMBER 2020)

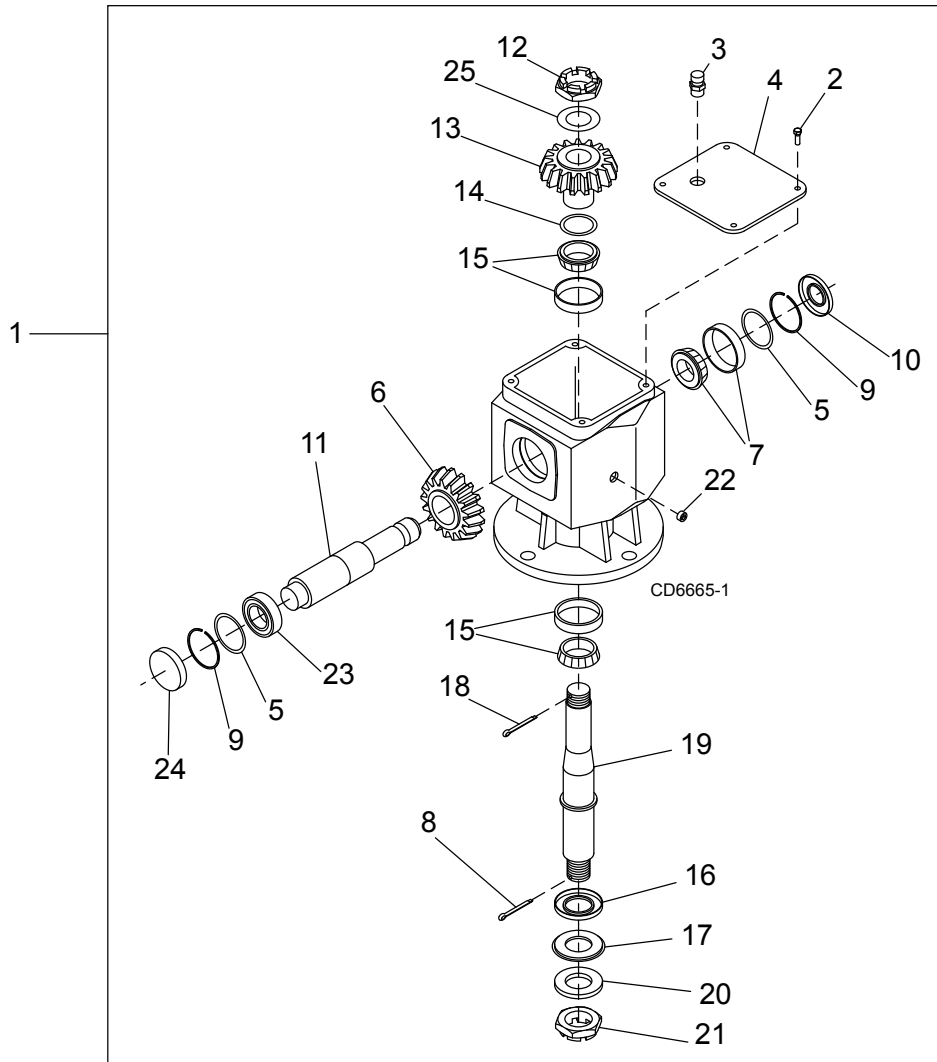

REF	PART	QTY	DESCRIPTION	REF	PART	QTY	DESCRIPTION
1	58803	1	Complete gearbox (58803 discontinued. Order 617154RP)	16	39289	1	Seal, 50 x 90 x 10
2	----	6 *	M8-1.25P x 14 mm HHCS	17	57338	1	Screen protection
3	57076	1	1/2 Vent plug	18	----	1 *	Cotter pin, B4 x 55 mm
4	----	1	Cover	19	----	1	Output shaft
5	57328	1	Shim kit, 60.3 x 71.7	20	610385RP	1	Flat washer, 31 x 56 x 4
6	----	1	Crown gear	21	W39323	1	M30-2.0P castle nut
7	57462	1	Bearing, cup & cone	22	27326	1	3/8 NPT Solid plug
8	----	1 *	Cotter pin, B6 x 60 mm	23	20890	1	Ball bearing
9	57466	2	Snap ring	24	57374	1	Oil cap
10	57463	1	Seal, 35 x 72 x 10	25	57094	1	Shim, 44 x 30.3 x 1
11	----	1	Input shaft, 1-3/8 6 spline	----	----	----	Not Serviced Separately
12	39261	1 *	M30-1.5P Castle nut	HHCS	----	----	Hex Head Cap Screw
13	----	1	Pinion gear	*	----	----	Standard hardware, obtain locally
14	57471	1	Shim kit, 50.3 x 70.3				
15	39263	2	Bearing, cup & cone				

## 44 Parts

MAN1289  
(04/30/2024)

# BB48.30 & BB60.30 DRIVELINE ASSEMBLY

(USED ON MACHINES BUILT SEPTEMBER 2020 OR LATER)

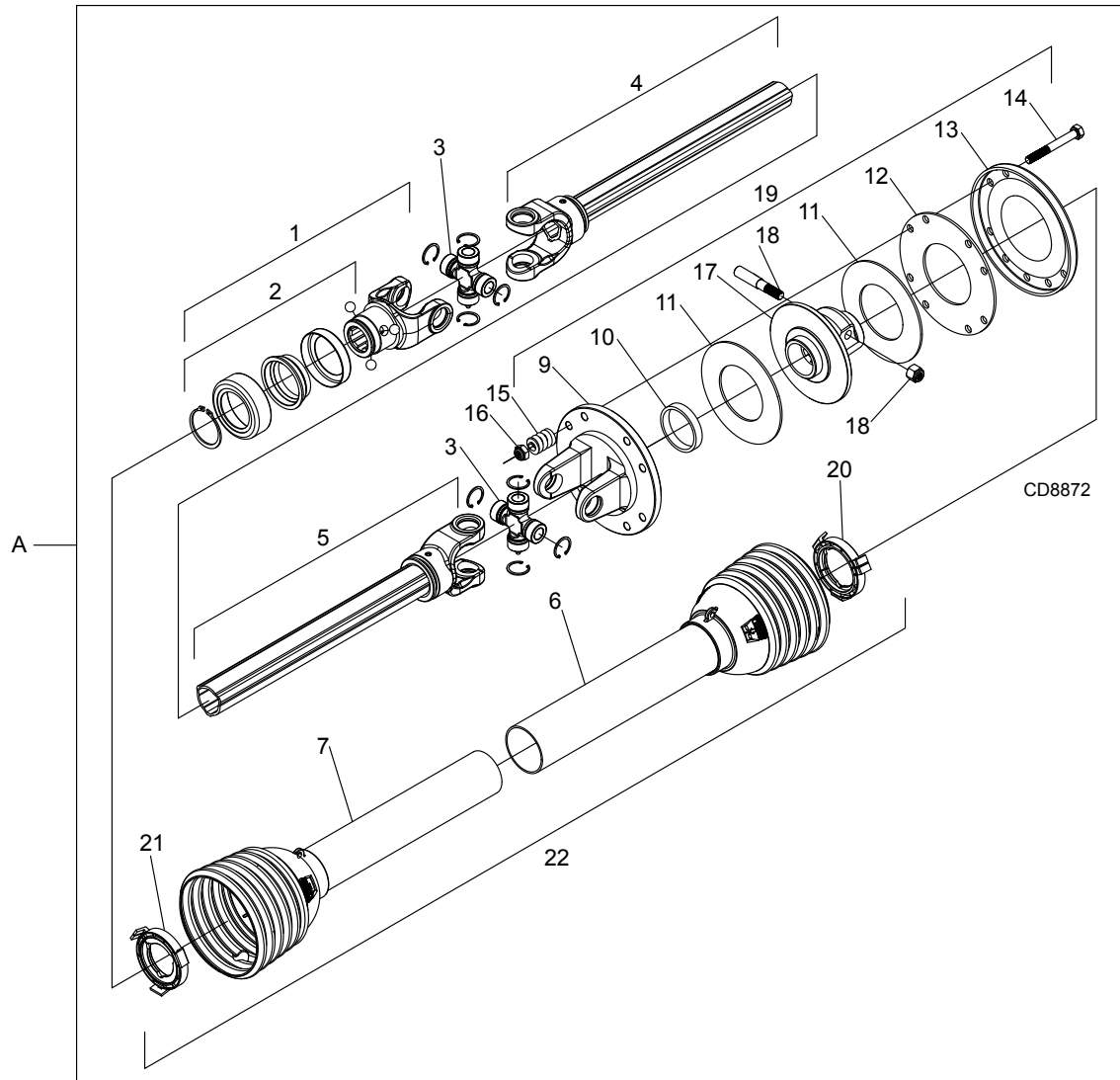

REF	PART	QTY	DESCRIPTION	REF	PART	QTY	DESCRIPTION
A	614317	1	Complete driveline and clutch asy	14	----	8 *	M10 x 1.5 x 85, HHCS
1	----	1	Complete collar yoke C12 1-3/8 - 6	15	----	8	Clutch spring
2	1044050	1	Lock collar repair kit	16	----	8 *	M10 x 1.5P Nylon lock nut
3	1044052	2	Cross & bearing kit	17	----	1	Clutch hub
4	----	1	Outer yoke & tube	18	1044091	1	Tapered pin & nut
5	----	1	Inner yoke & tube	19	----	1	Friction clutch assembly
6	----	1	Outer shield with bearing	20	----	1	Outer shield bearing
7	----	1	Inner shield with bearing	21	----	1	Inner shield bearing
9	----	1	Flanged yoke	22	639691	1	Shield Kit Complete (includes 6, 7, 20, 21, 24)
10	1043994	1	Bushing	23	33347	1	Decal, Danger, Guard Missing
11	1044083	2	Friction disc	24	18864	1	Decal, Danger, Rotating Driveline
12	----	1	Internal disc				
13	----	1	Pressure plate				

\* Standard Hardware, obtain locally

MAN1289  
(04/30/2024)

**Parts 45**

# BB48.30 & BB60.30 DRIVELINE ASSEMBLY

(USED ON MACHINES BUILT PRIOR TO SEPTEMBER 2020)

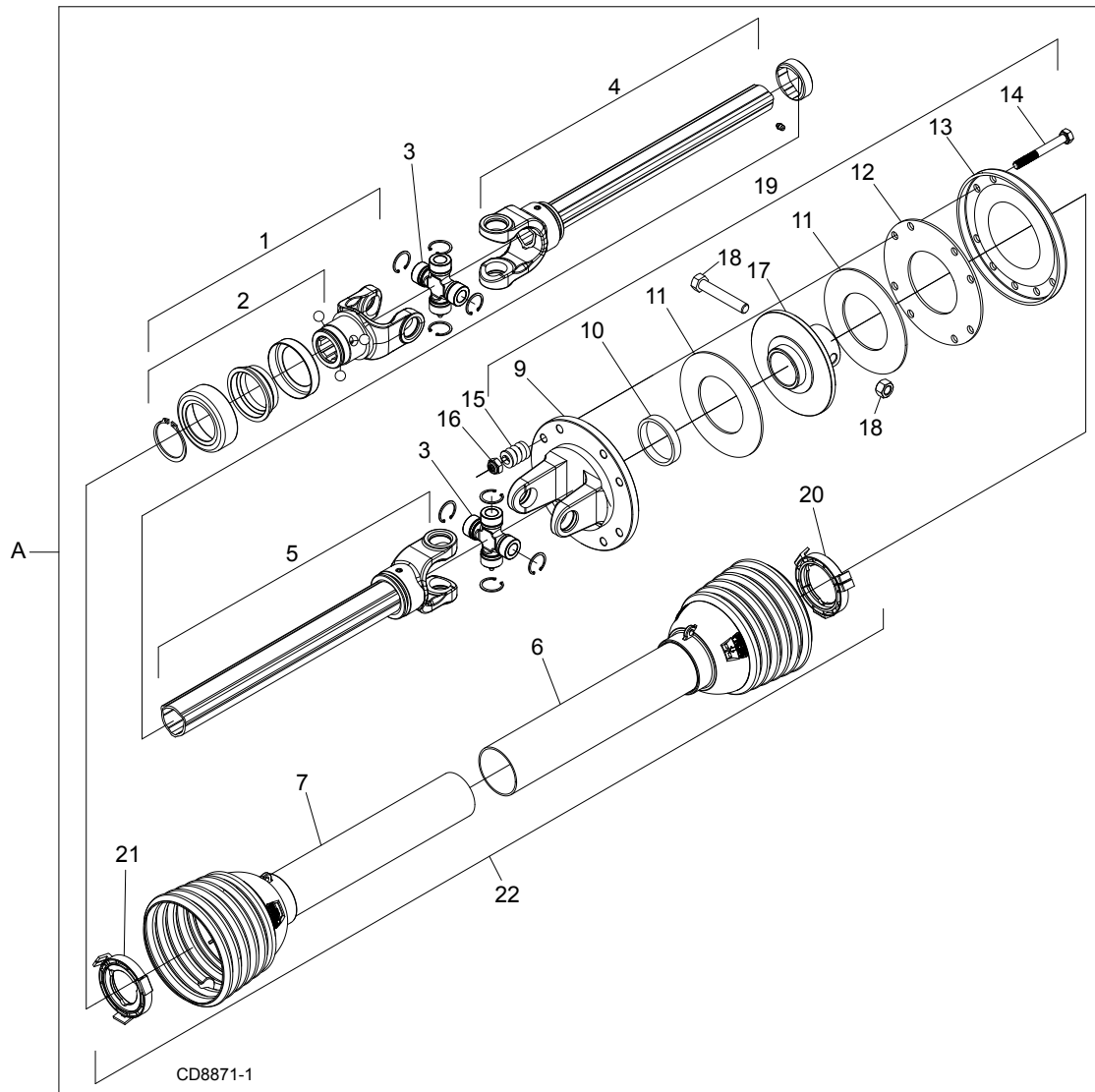

REF	PART	QTY	DESCRIPTION	REF	PART	QTY	DESCRIPTION
A	601749	1	Complete driveline and clutch asy (For use on gearbox input shaft without splines)	15	----	8	Clutch spring
1	----	1	Complete collar yoke C12 1-3/8 - 6	16	----	8	M10 x 1.5P Nylon lock nut
2	1044050	1	Lock collar repair kit	17	----	1	Clutch hub
3	1044052	2	Cross & bearing kit	18	----	*	1/2 NC X 3 HHCS GR*8
4	----	1	Outer yoke & tube	----	----	*	1/2 NC Lock nut
5	----	1	Inner yoke & tube	19	----	1	Friction clutch assembly
6	----	1	Outer shield with bearing	20	----	1	Outer shield bearing
7	----	1	Inner shield with bearing	21	----	1	Inner shield bearing
9	----	1	Flanged yoke	22	639691	1	Shield Kit Complete (includes 6, 7, 20, 21, 24)
10	1043994	1	Bushing	23	33347	1	Decal, Danger, Guard Missing
11	1044083	2	Friction disc	24	18864	1	Decal, Danger, Rotating Driveline
12	----	1	Internal disc	25	----	1	Bearing, Shield Support
13	----	1	Pressure plate				
14	----	8	M10 x 1.5P x 85, HHCS			*	Standard Hardware, obtain locally

## 46 Parts

MAN1289  
(04/30/2024)

# BB72.30 DRIVELINE ASSEMBLY

(USED ON MACHINES BUILT SEPTEMBER 2020 OR LATER)

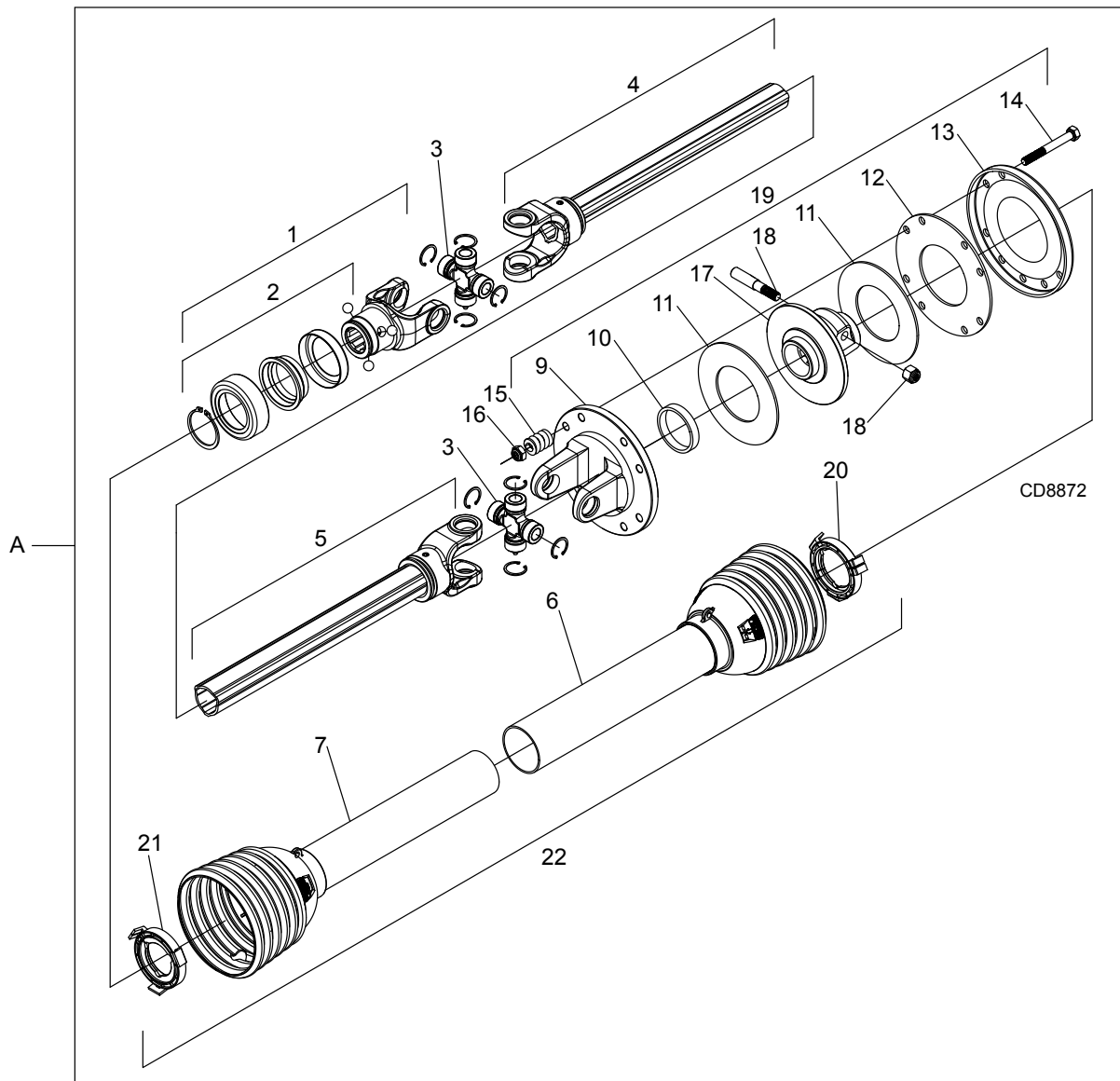

REF	PART	QTY	DESCRIPTION	REF	PART	QTY	DESCRIPTION
A	601750	1	Complete driveline and clutch asy	14	----	8 *	M10 x 1.5 x 85, HHCS
1	----	1	Complete collar yoke C12 1-3/8 - 6	15	----	8	Clutch spring
2	1044050	1	Lock collar repair kit	16	----	8 *	M10 x 1.5P Nylon lock nut
3	1044052	2	Cross & bearing kit	17	----	1	Clutch hub
4	----	1	Outer yoke & tube	18	1044091	1	Tapered pin & nut
5	----	1	Inner yoke & tube	19	----	1	Friction clutch assembly
6	----	1	Outer shield with bearing	20	----	1	Outer shield bearing
7	----	1	Inner shield with bearing	21	----	1	Inner shield bearing
9	----	1	Flanged yoke	22	639691	1	Shield Kit Complete (includes 6, 7, 20, 21, 24)
10	1043994	1	Bushing	23	33347	1	Decal, Danger, Guard Missing
11	1044083	2	Friction disc	24	18864	1	Decal, Danger, Rotating Driveline
12	----	1	Internal disc				
13	----	1	Pressure plate				
					*		Standard Hardware, obtain locally

MAN1289  
(04/30/2024)

**Parts 47**

# BB72.30 DRIVELINE ASSEMBLY

(USED ON MACHINES BUILT PRIOR TO SEPTEMBER 2020)

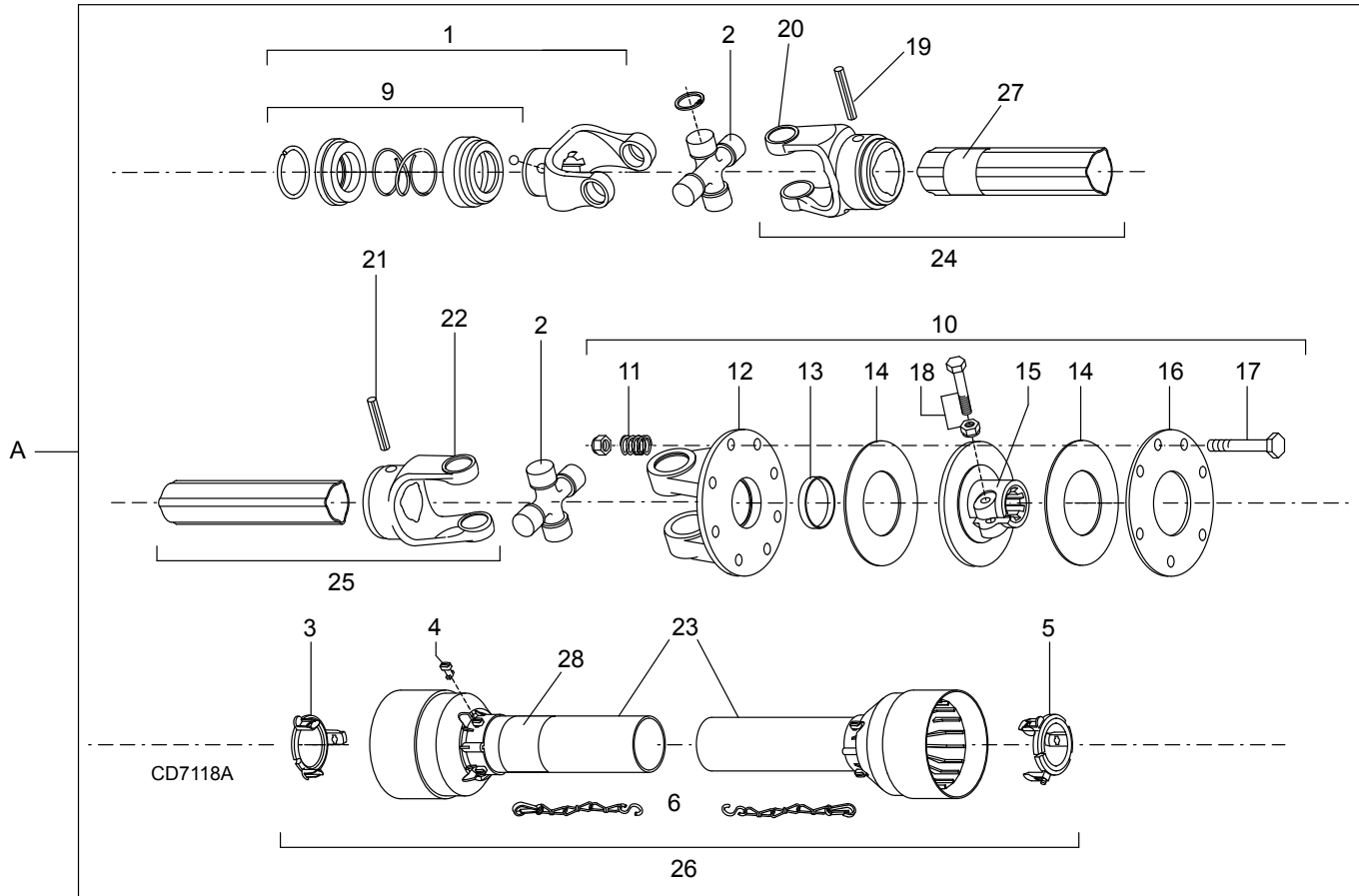

REF	PART	QTY	DESCRIPTION	REF	PART	QTY	DESCRIPTION
A	1020901	1	Complete drive assembly (1020901 no longer available. Order 601750)	17	----	8 *	M10 x 80 mm HHCS & nut
1	----	1	Complete collar yoke 1-3/8 - 6	18	----	1 *	M12 x 1.25P x 60 mm HHCS & nut
2	----	2	Cross & bearing kit	19	----	1	Flex pin
3	----	1	Outer cone fix ring	20	----	1	Outer yoke tube
4	----	6	Shield retainer	21	----	1	Flex pin
5	----	1	Inner cone fix ring	22	----	1	Inner tube yoke
6	----	2	Shield tether chain	23	----	1	Shield, tube assembly
9	1001340	1	Lock collar repair kit	24	----	1	Outer yoke & tube
10	----	1	Friction clutch	25	----	1	Inner yoke & tube
11	----	8	Spring	26	639713	1	Shield complete (includes 3, 4, 5, 6, 23)
12	----	1	Flange yoke	27	33347	1	Decal, Danger, Guard Missing
13	1001313	1	Bushing	28	18864	1	Decal, Danger, Rotating Driveline
14	1001314	2	Friction disc - lining ring			*	Standard Hardware, obtain locally
15	----	1	Flange hub				
16	----	1	Pressure plate				

**48 Parts**

MAN1289  
(04/30/2024)



## BB72.40 & BB84.40 DRIVELINE ASSEMBLY

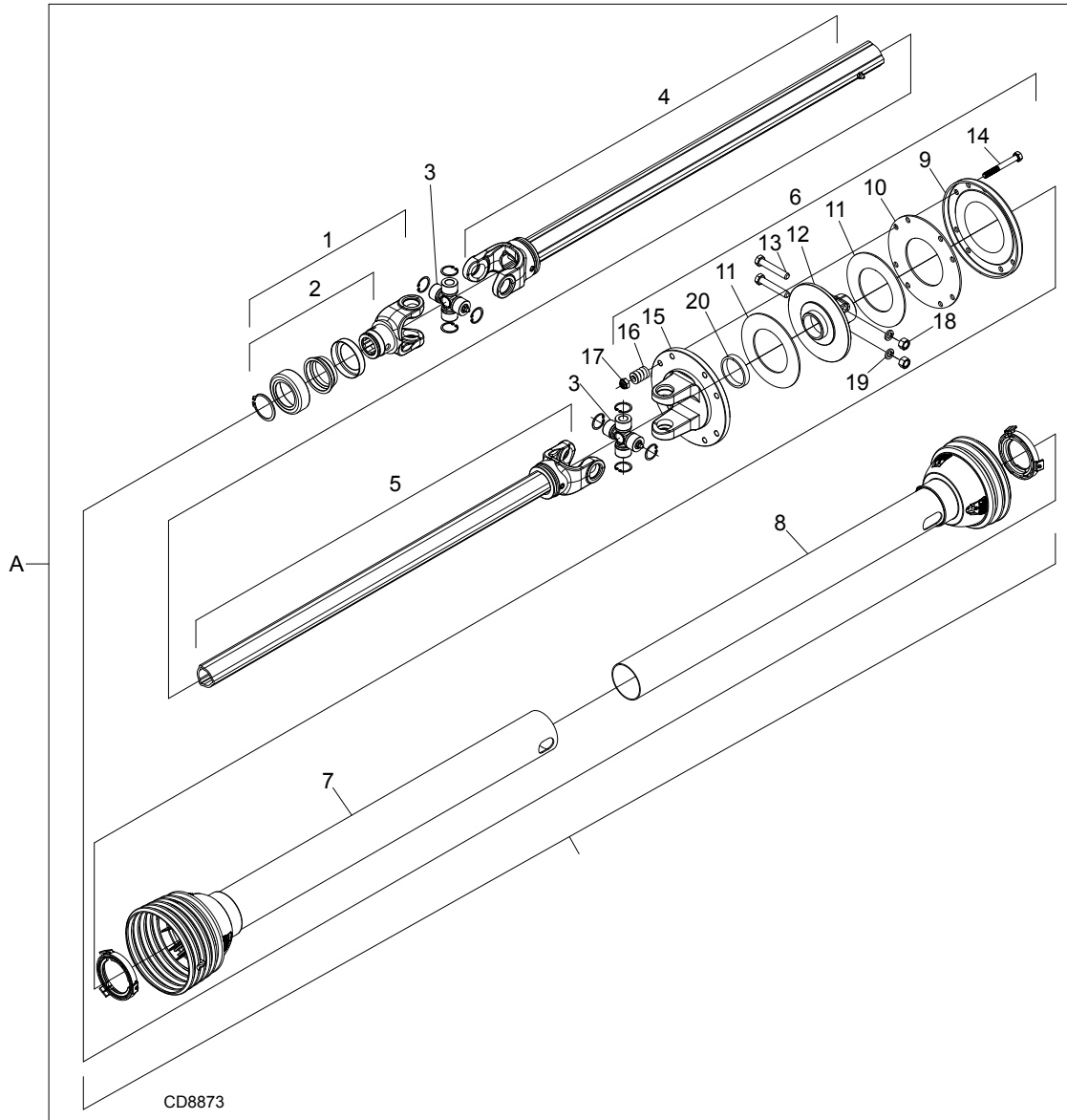

REF	PART	QTY	DESCRIPTION	REF	PART	QTY	DESCRIPTION
A	601751	1	Complete driveline and clutch asy	13	----	2 *	M12 x 1.75 x 75, HHCS
1	----	1	Complete collar yoke	14	----	8 *	M10 x 1.5P x 100, HHCS
2	1044050	1	Lock collar repair kit	15	----	1	Flanged yoke
3	605276	2	Cross & bearing kit	16	----	8	Clutch spring
4	----	1	Outer yoke & tube	17	----	8 *	M10 x 1.5P Nylon lock nut
5	----	1	Inner yoke & tube	18	----	2 *	M12 x 1.75 Hex nut
6	----	1	Friction clutch assembly	19	----	2 *	M12 Lock washer
7	----	1	Outer shield with bearing	20	1043994	1	Bushing
8	----	1	Inner shield with bearing	21	639692	1	Shield Kit Complete (includes 7, 8, 23)
9	----	1	Pressure plate	22	33347	1	Decal, Danger, Guard Missing
10	----	1	Internal disc	23	18864	1	Decal, Danger, Rotating Driveline
11	605286	2	Friction disc (Prior to July 2020)				
	645113	2	Friction Disc (July 2020 or later)				
12	----	1	Clutch hub			*	Standard Hardware, obtain locally

MAN1289  
(04/30/2024)

Parts 49

## BBXX.30, BBXX.40 TAILWHEEL ASSEMBLY

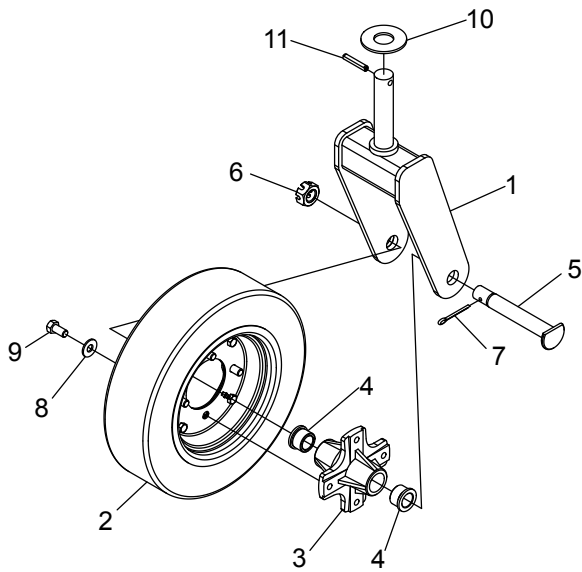

BBXX.30 TAILWHEEL

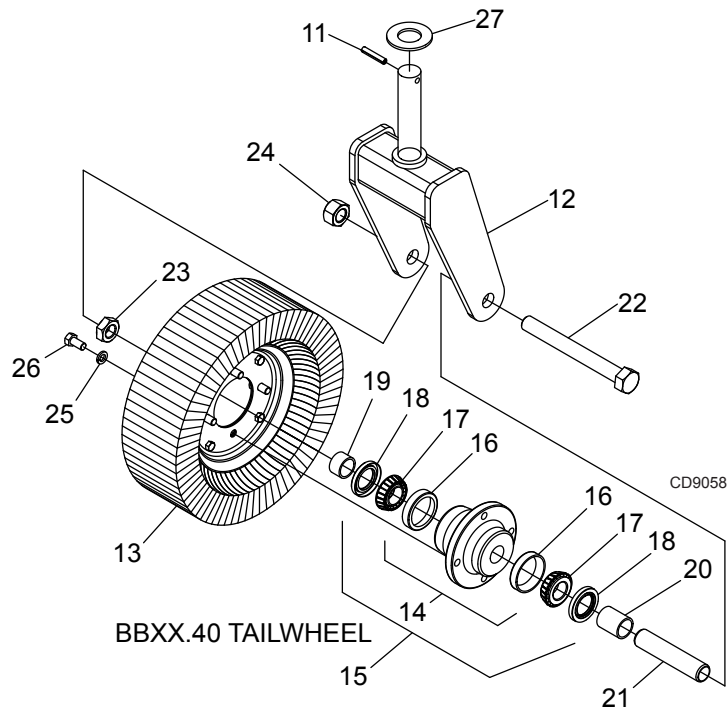

BBXX.40 TAILWHEEL

### BB48.30, BB60.30, BB72.30

REF	PART	QTY	DESCRIPTION
1	608158RP	1	Tailwheel clevis
2	1019636	1	4 x 8 rim & laminated tire, 4" wide
3	1030522	1	Hub, 4-bolt
4	1030524	2	Bushing, flange .990 x 1.394 x .98
5	1030523	1	M24 - 2.0P Axle bolt
6	1032105	1	M24 - 2.0P Slotted nut
7	----	1 *	Cotter pin
8	854	4 *	1/2 flat washer
9	25475	4 *	1/2 NC x 1 HHCS GR5
10	7163	1 *	1-1/4 std flat washer
11	4674	1	3/8 x 2 spirol pin

\* Standard hardware, obtain locally

### BB72.40, BB84.40

REF	PART	QTY	DESCRIPTION
11	4674	1	3/8 x 2 spirol pin
12	610171RP	1	Tailwheel clevis
13	12577	1	4 x 8 rim & laminated tire, 5" wide
14	15591	1	Hub w/ cups (includes item 16)
15	15277RP	1	Hub assembly (includes items 16 - 18)
16	309	2	Bearing cup
17	310	2	Bearing cone
18	314	2	Seal
19	15574	1	1.25 x 1.50 x .903 sleeve
20	15575	1	1.25 x 1.50 x 1.86 sleeve
21	15573	1	1.00 x 1.25 x 5.81 sleeve
22	15087	1	1 NC x 9 HHCS GR5
23	1386	1	1 NC hex jam nut
24	34279	1	1 NC hex lock nut
25	855	5 *	1/2 std lock washer
26	4119	5 *	1/2 NF x 1 HHCS GR5
27	2370	1	1.62 x 3 x .18 washer

\* Standard hardware, obtain locally

HHCS Hex head cap screw

**50 Parts**

MAN1289  
(04/30/2024)

## FRONT BELTING & REAR BAND

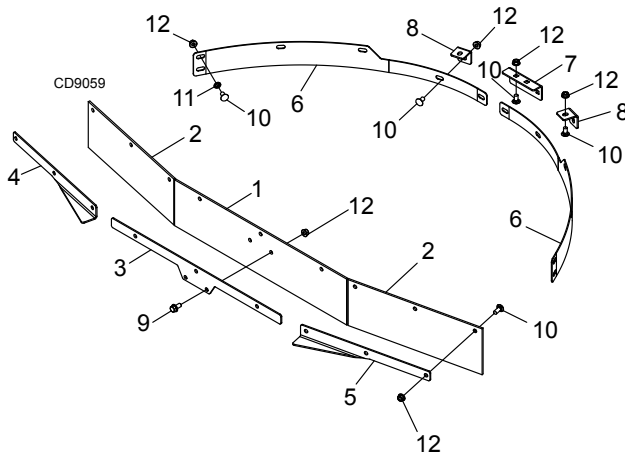

REF	PART	QTY	DESCRIPTION
1	610108	1	Rubber deflector 7.50 x 32.50
2	610109	2	Rubber deflector 7.50 x 9.00 - BB48.30
	610110	2	Rubber deflector 7.50 x 15.00 - BB60.30
	610111	2	Rubber deflector 7.50 x 21.21 - BB72.30, BB72.40
	610112	2	Rubber deflector 7.50 x 27.38 - BB84.40
3	608168RP	1	Center bar
4	610396RP	1	Right bar - BB48.30
	610400RP	1	Right bar - BB60.30
	608166RP	1	Right bar - BB72.30, BB72.40
	610404RP	1	Right bar - BB84.40
5	610397RP	1	Left bar - BB48.30
	610401RP	1	Left bar - BB60.30
	608167RP	1	Left bar - BB72.30, BB72.40
	610405RP	1	Left bar - BB84.40
6	610398RP	2	Rear band - BB48.30
	610403RP	2	Rear band - BB60.30
	608169RP	2	Rear band - BB72.30, BB72.40
	610406RP	2	Rear band - BB84.40
7	608170RP	1	Rear bracket, center
8	610395RP	2	Rear bracket, outer
9	1045070	2 *	1/2 NC x 1 HFS GR5
10	2615	28 *	1/2 NC x 1-1/4 carriage bolt (qty varies per model)
11	610103	10	Nut, 1/2 push-on bolt retainer
12	11900	30 *	1/2 NC flange lock nut (qty varies per model)

\* Standard hardware, obtain locally

## FRONT & REAR CHAIN SHIELDING

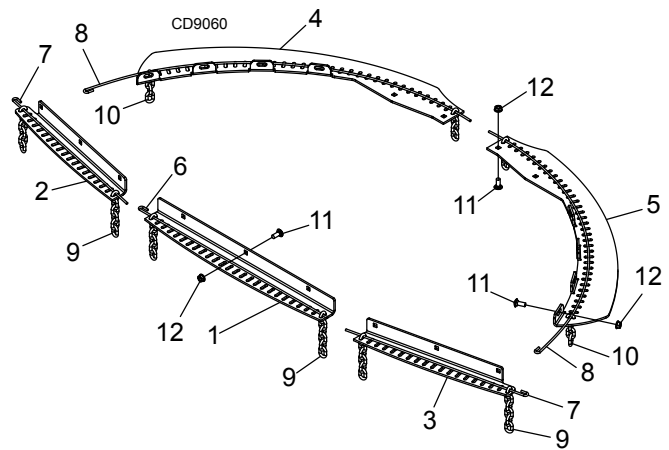

REF	PART	QTY	DESCRIPTION
1	608161RP	1	Front center chain bracket
2	610298RP	1	Front right chain bracket - BB48.30
	610294RP	1	Front right chain bracket - BB60.30
	608162RP	1	Front right chain bracket - BB72.30, BB72.40
	610388RP	1	Front right chain bracket - BB84.40
3	610299RP	1	Front left chain bracket - BB48.30
	610295RP	1	Front left chain bracket - BB60.30
	608163RP	1	Front left chain bracket - BB72.30, BB72.40
	610387RP	1	Front left chain bracket - BB84.40
4	610300RP	1	Rear right chain bracket - BB48.30
	610296RP	1	Rear right chain bracket - BB60.30
	608164RP	1	Rear right chain bracket - BB72.30, BB72.40
	610390RP	1	Rear right chain bracket - BB84.40
5	610301RP	1	Rear left chain bracket - BB48.30
	610297RP	1	Rear left chain bracket - BB60.30
	608165RP	1	Rear left chain bracket - BB72.30, BB72.40
	610389RP	1	Rear left chain bracket - BB84.40
6	1003645	1	Pin, 25 to 27 chains
7	1007852	2	Pin, 7 to 9 chains - BB48.30
	1003639	2	Pin, 13 to 16 chains - BB60.30
	1003643	2	Pin, 19 to 21 chains - BB72.30, BB72.40
	1003644	2	Pin, 22 to 24 chains - BB84.40
8	57138	2	Pin, rolled 28 to 30 chains - BB48.30, BB60.30
	57085	2	Pin, rolled 37 to 39 chains - BB72.30, BB72.40
	57146	2	Pin, rolled 40 to 42 chains - BB84.40
9	3994	74	5/16 chain, 5-link (qty varies per model)
10	1041054	78	5/16 chain, 3-link (qty varies per model)
11	2615	22 *	1/2 NC x 1-1/4 carriage bolt (qty varies per model)
12	11900	22 *	1/2 NC flange lock nut (qty varies per model)

\* Standard hardware, obtain locally  
HHCS Hex head cap screw

## DUAL TAILWHEEL ASSEMBLY BB84.40 (OPTIONAL)

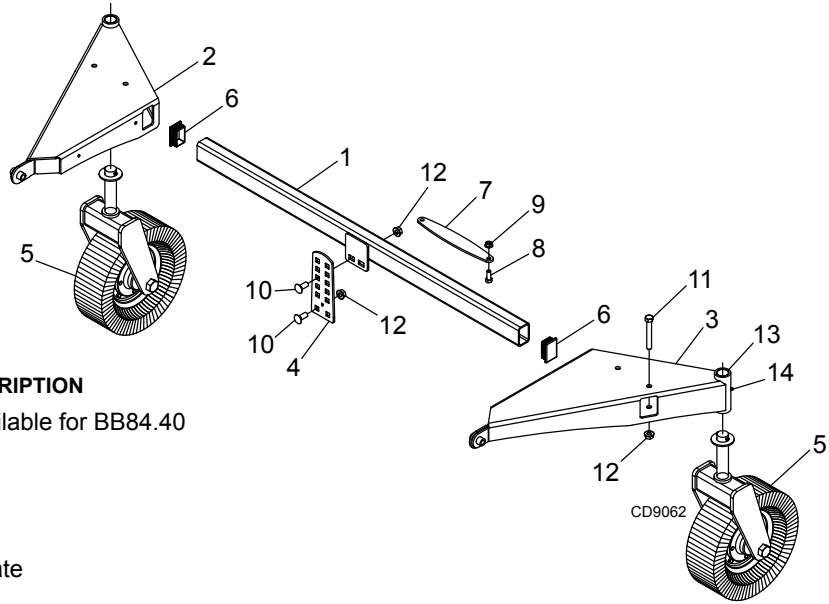

REF	PART	QTY	DESCRIPTION
	610225	1	Dual tailwheel kit available for BB84.40
1	610224RP	1	Tube weldment
2	610222RP	1	Right arm weldment
3	610223RP	1	Left arm weldment
4	610221RP	1	Height adjustment plate
5	----	2	Tailwheel assembly
6	1042108	2	2 x 3 black plastic plug
7	610384RP	1	Rear shield extension plate
8	6100	2 *	1/2 NC x 1-1/4 HHCS GR5
9	11900	2 *	1/2 NC flange lock nut
10	5607	4 *	5/8 NC x 1-1/2 carriage bolt
11	3097	4 *	5/8 NC x 4-1/2 HHCS GR5
12	19025	8 *	5/8 NC flange lock nut
13	W11011	4	1-1/2 x 1-5/8 x 1-1/2 bronze bush- ing
14	12296	2 *	1/4 - 28 straight grease fitting, 15/ 32 long

\* Standard hardware, obtain locally  
 HHCS Hex Head Cap Screw

## CHECK CHAIN ASSEMBLY

REF	PART	QTY	DESCRIPTION
	10521	1	Check chain complete
1	7906	2	Check chain bracket, lower
2	18048	2	3/8 chain, 32-link and check lug
3	2377	1 *	3/4 NC x 6 HHCS GR5
4	2371	1 *	3/4 NC hex lock nut
5	12274	2 *	5/8 NC x 2-1/4 HHCS GR5
6	3632	2 *	5/8 flat washer
7	6239	2 *	5/8 NC hex lock nut

\* Standard hardware, obtain locally  
 HHCS Hex Head Cap Screw

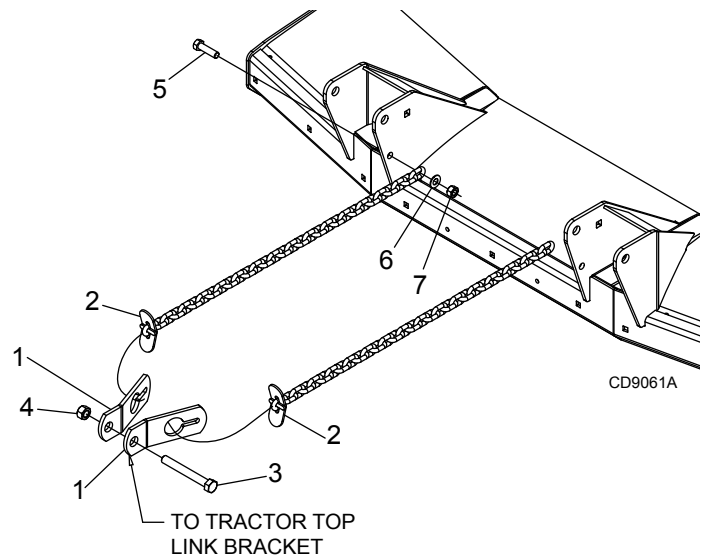

**52 Parts**

MAN1289  
 (04/30/2024)

# BOLT TORQUE CHART

Always tighten hardware to these values unless a different torque value or tightening procedure is listed for a specific application.

Fasteners must always be replaced with the same grade as specified in the manual parts list.

Always use the proper tool for tightening hardware: SAE for SAE hardware and Metric for metric hardware. Make sure fastener threads are clean and you start thread engagement properly.

All torque values are given to specifications used on hardware defined by SAE J1701 MAR 99 & J1701M JUL 96.

## SAE SERIES TORQUE CHART

SAE Bolt Head Identification



Ⓐ	Diameter (Inches)	Wrench Size	Marking on Head					
			SAE 2		SAE 5		SAE 8	
			lbs-ft	N-m	lbs-ft	N-m	lbs-ft	N-m
1/4"	7/16"	6	8	10	13	14	18	
5/16"	1/2"	12	17	19	26	27	37	
3/8"	9/16"	23	31	35	47	49	67	
7/16"	5/8"	36	48	55	75	78	106	
1/2"	3/4"	55	75	85	115	120	163	
9/16"	13/16"	78	106	121	164	171	232	
5/8"	15/16"	110	149	170	230	240	325	
3/4"	1-1/8"	192	261	297	403	420	569	
7/8"	1-5/16"	306	416	474	642	669	907	
1"	1-1/2"	467	634	722	979	1020	1383	

## TYPICAL WASHER INSTALLATIONS

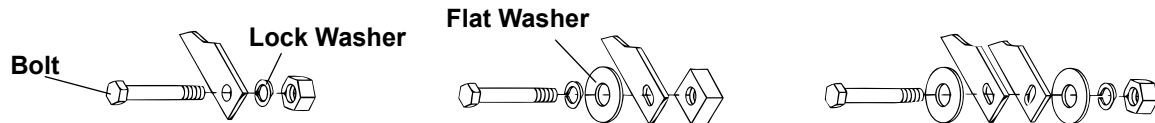

## METRIC SERIES TORQUE CHART

Metric Bolt Head Identification

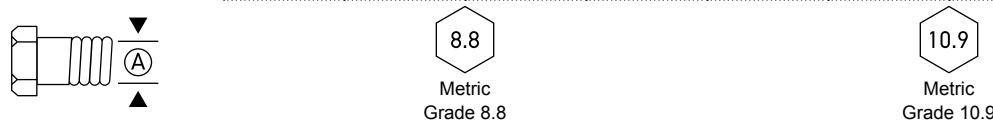

Ⓐ	Diameter & Thread Pitch (Millimeters)	Wrench Size	Marking on Head								Ⓐ	Diameter & Thread Pitch (Millimeters)
			Coarse Thread				Fine Thread					
			Metric 8.8		Metric 10.9		Metric 8.8		Metric 10.9			
N-m	lbs-ft	N-m	lbs-ft	N-m	lbs-ft	N-m	lbs-ft					
6 x 1.0	10 mm	8	6	11	8	8	6	11	8	6 x 1.0		
8 x 1.25	13 mm	20	15	27	20	21	16	29	22	8 x 1.0		
10 x 1.5	16 mm	39	29	54	40	41	30	57	42	10 x 1.25		
12 x 1.75	18 mm	68	50	94	70	75	55	103	76	12 x 1.25		
14 x 2.0	21 mm	109	80	151	111	118	87	163	120	14 x 1.5		
16 x 2.0	24 mm	169	125	234	173	181	133	250	184	16 x 1.5		
18 x 2.5	27 mm	234	172	323	239	263	194	363	268	18 x 1.5		
20 x 2.5	30 mm	330	244	457	337	367	270	507	374	20 x 1.5		
22 x 2.5	34 mm	451	332	623	460	495	365	684	505	22 x 1.5		
24 x 3.0	36 mm	571	421	790	583	623	459	861	635	24 x 2.0		
30 x 3.0	46 mm	1175	867	1626	1199	1258	928	1740	1283	30 x 2.0		

# BOLT SIZE CHART

**NOTICE:** Chart shows bolt thread sizes and corresponding head (wrench) sizes for standard SAE and metric bolts.

## SAE BOLT THREAD SIZES

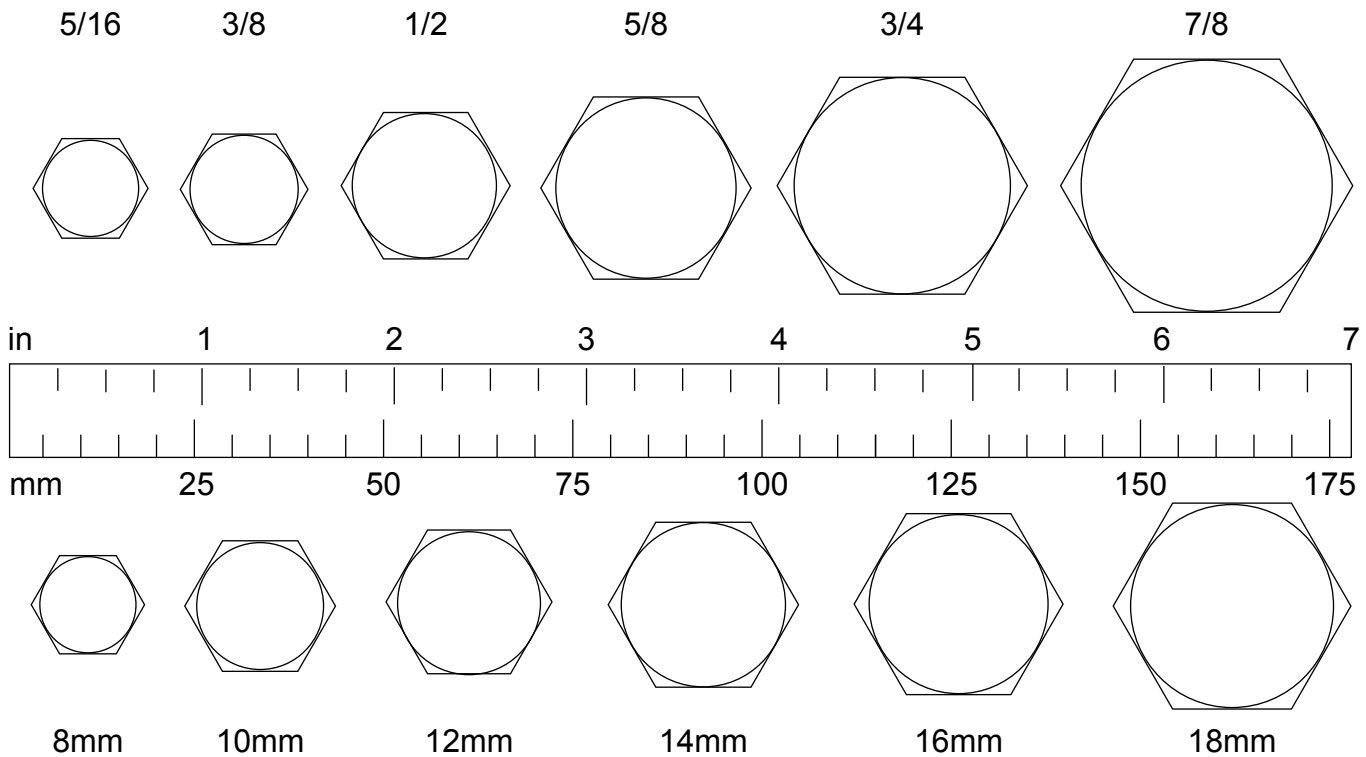

## METRIC BOLT THREAD SIZES

## ABBREVIATIONS

AG . . . . . Agriculture	HT . . . . . Heat-Treated	ORBM . . . . . O-Ring Boss - Male
ASABE . . . . . American Society of Agricultural & Biological Engineers (formerly ASAE)	JIC . . . . . Joint Industry Council 37° Degree Flare	P . . . . . Pitch
ASAE . . . . . American Society of Agricultural Engineers	LH . . . . . Left Hand	PBY . . . . . Power-Beyond
ATF . . . . . Automatic Transmission Fluid	LT . . . . . Left	psi . . . . . Pounds per Square Inch
BSPP . . . . . British Standard Pipe Parallel	m . . . . . Meter	PTO . . . . . Power Take Off
BSPTM . . . . . British Standard Pipe Tapered Male	mm . . . . . Millimeter	QD . . . . . Quick Disconnect
CV . . . . . Constant Velocity	M . . . . . Male	RH . . . . . Right Hand
CCW . . . . . Counter-Clockwise	MPa . . . . . Mega Pascal	ROPS . . . . . Roll-Over Protective Structure
CW . . . . . Clockwise	N . . . . . Newton	RPM . . . . . Revolutions Per Minute
F . . . . . Female	NC . . . . . National Coarse	RT . . . . . Right
FT . . . . . Full Thread	NF . . . . . National Fine	SAE . . . . . Society of Automotive Engineers
GA . . . . . Gauge	NPSM . . . . . National Pipe Straight Mechanical	UNC . . . . . Unified Coarse
GR (5, etc.) . . . . . Grade (5, etc.)	NPT . . . . . National Pipe Tapered	UNF . . . . . Unified Fine
HHCS . . . . . Hex Head Cap Screw	NPT SWF . . . . . National Pipe Tapered Swivel Female	UNS . . . . . Unified Special

# INDEX

## ASSEMBLY

- Assemble Cutter 32
- Dealer Set-Up Instructions 31
- Disassemble Shipping Unit 31
- Install Check Chain (Optional) 34
- Install Driveline 32
- Install Dual Tailwheel - BB84.40D only 34
- Install Safety Shielding 33
  - Front and Belt 33
  - Front and Rear Chain 33
  - Rear Steel Band 33

## DEALER CHECKLISTS

- Delivery (Dealer's Responsibility) 35
- Pre-Delivery (Dealer's Responsibility) 35

## DEALER SERVICE

- Crossbar
  - Installation 29
  - Removal 28
- Gearbox Maintenance 23
  - Horizontal Leak Repair 24, 26
  - Seal Installation 23
  - Seal Replacement 23
  - Vertical Shaft Repair 24, 26
- Gearbox Repair - BBXX.30
  - Disassemble Gearbox 24
  - Reassemble Gearbox 24
  - Reinstall Gearbox 28
  - Remove Gearbox 24
- Spindle Gearbox Repair - BBXX.40
- Disassemble Gearbox 26
  - Reassemble Gearbox 26
  - Reinstall Gearbox 27
  - Remove Gearbox 26
- Universal Joint
  - Assembly 30
  - Disassembly 29
  - Repair 29

## GENERAL

- Abbreviations 54
- Bolt Size Chart 54
- Bolt Torque Chart 53
- General Information 4
- Introduction 2
- Obtaining Replacement Manuals 2
- Product Registration 2
- Specifications 4
- Table of Contents 3
- Warranty 2

## OPERATION

- Adjustments
  - Check Chains 16
  - Cutting Height 15
  - Shredding 16
- Attaching Cutter to Tractor
  - BBXX.30
    - Attachment 12
    - Quick Hitch 12
  - BBXX.40
    - Quick Hitch 13
    - Standard Hitch 13
- Driveline
  - Attachment 13
  - Interference Check 15
  - PTO Installation & Removal 14
  - Shortening 14
- Mowing Speed 12
- Operating Technique 16
- Pre-Operation Checklist (Owner's Responsibility) 17
- Storage 17
- Tractor Stability 12
- Transporting 17

## OWNER SERVICE

- Blade
  - Installation 20
  - Removal 19
  - Servicing 19
  - Sharpening 20
- Blocking Method 18
- Cleaning
  - After Each Use 21
  - Periodically or Before Extended Storage 21
- Lubrication Information 18
  - Driveline 18
  - Gearbox 18
  - Lubrication Chart 19
- Shielding Repair 21
- Slip Clutch Adjustment 20
- Troubleshooting 22

## PARTS

- Index to Parts Lists 37

## SAFETY

- Checklists
  - Delivery (Dealer's Responsibility) 35
  - Pre-Delivery (Dealer's Responsibility) 35
  - Pre-Operation (Owner's Responsibility) 17
- Free Mower Safety Video Order Form 5–6
- Safety & Instructional Decals 10–11
- Safety Rules 7–9
- Safety Symbols Explained 2

**PART NO.**  
**MAN1289**

**WOODS®**

2606 South Illinois Route 2  
Post Office Box 1000  
Oregon, Illinois 61061 USA

800-319-6637 tel  
800-399-6637 fax  
woodsequipment.com



© 2024 Woods Equipment Company. All rights reserved. Woods® and the Woods logo are trademarks of Woods Equipment Company. All other trademarks, trade names, or service marks not owned by Woods Equipment Company that appear in this manual are the property of their respective companies or mark holders. Specifications subject to change without notice.