

PRECISION SUPER SEEDER

PSS48

PSS60

PSS72

PSS84

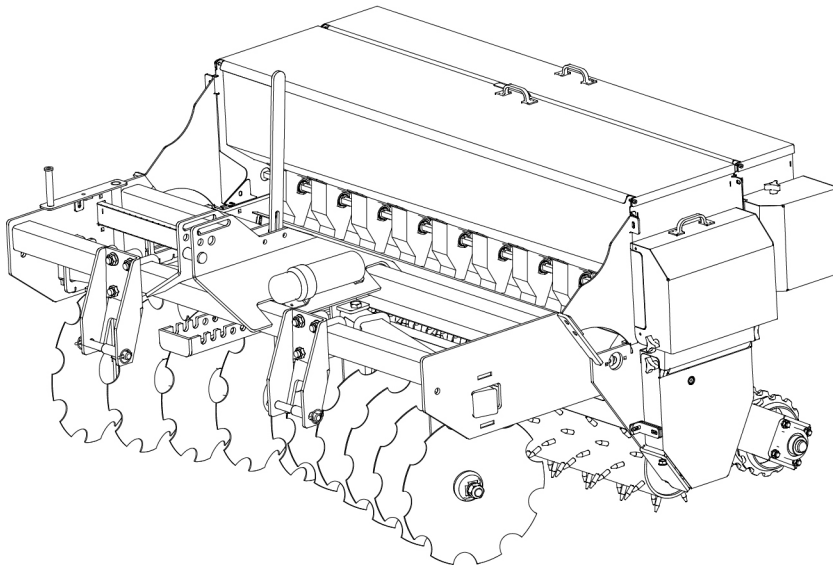
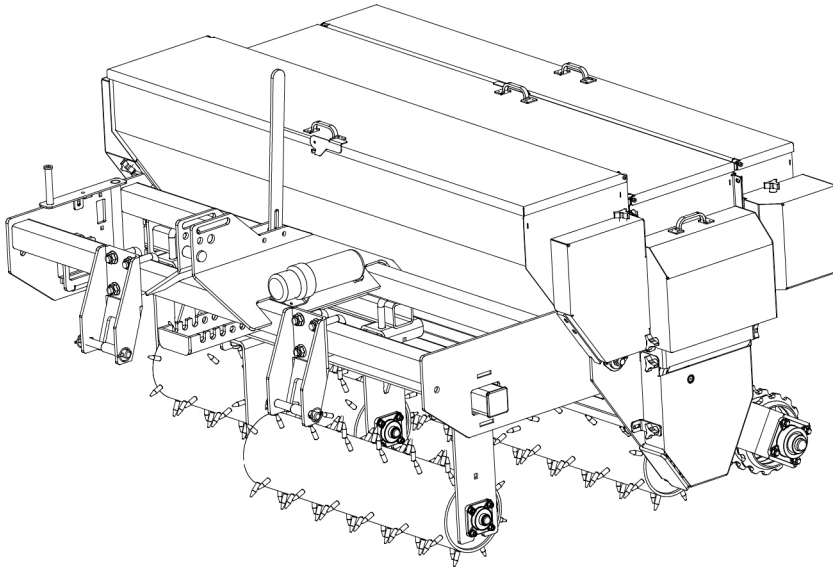

MAN0988

(Rev. 8/27/2021)

WOODS®

OPERATOR'S MANUAL

TO THE DEALER:

Assembly and proper installation of this product is the responsibility of the Woods® dealer. Read manual instructions and safety rules. Make sure all items on the Dealer's Pre-Delivery and Delivery Check Lists in the Operator's Manual are completed before releasing equipment to the owner.

The dealer must complete the online Product Registration form at the Woods Dealer Website which certifies that all Dealer Check List items have been completed. Dealers can register all Woods product at dealer.WoodsEquipment.com under Product Registration.

Failure to register the product does not diminish customer's warranty rights.

TO THE OWNER:

Read this manual before operating your Woods equipment. The information presented will prepare you to do a better and safer job. Keep this manual handy for ready reference. Require all operators to read this manual carefully and become acquainted with all adjustment and operating procedures before attempting to operate. Replacement manuals can be obtained from your dealer. To locate your nearest dealer, check the Dealer Locator at www.WoodsEquipment.com, or in the United States and Canada call 1-800-319-6637.

The equipment you have purchased has been carefully engineered and manufactured to provide dependable and satisfactory use. Like all mechanical products, it will require cleaning and upkeep. Lubricate the unit as specified. Observe all safety information in this manual and safety decals on the equipment.

For service, your authorized Woods dealer has trained mechanics, genuine Woods service parts, and the necessary tools and equipment to handle all your needs.

Use only genuine Woods service parts. Substitute parts will void the warranty and may not meet standards required for safe and satisfactory operation. Record the model number and serial number of your equipment in the spaces provided:

Model: _____ **Date of Purchase:** _____

Serial Number: (see Safety Decal section for location) _____

Provide this information to your dealer to obtain correct repair parts.

Throughout this manual, the term **NOTICE** is used to indicate that failure to observe can cause damage to equipment. The terms **CAUTION**, **WARNING**, and **DANGER** are used in conjunction with the Safety-Alert Symbol (a triangle with an exclamation mark) to indicate the degree of hazard for items of personal safety.



This is the safety alert symbol. It is used to alert you to potential physical injury hazards. Obey all safety messages that follow this symbol to avoid possible injury or death.



Indicates a hazardous situation that, if not avoided, will result in death or serious injury.



Indicates a hazardous situation that, if not avoided, could result in death or serious injury.



Indicates a hazardous situation that, if not avoided, could result in minor or moderate injury.

**IMPORTANT
or NOTICE**

Is used to address practices not related to physical injury.

NOTE Indicates helpful information.

ALITEC™

CENTRAL FABRICATORS®

GANNON®

WAIN-ROY®

WOODS®

WOODS®

2 Introduction

Gen'l (Rev. 2/25/2016)

TABLE OF CONTENTS

INTRODUCTION	2
SPECIFICATIONS	4
GENERAL INFORMATION	4
SAFETY	5
SAFETY RULES	5
TRAINING	5
PREPARATION	5
OPERATION	5
TRANSPORTATION	6
MAINTENANCE	6
STORAGE	7
SAFETY & INSTRUCTIONAL DECALS	8
OPERATION	11
OPERATION	11
ATTACHING GROUND SEEDER TO TRACTOR	13
HITCHING PRECISION SUPER SEEDER TO TRACTOR	14
PRECISION SUPER SEEDER ATTITUDE ADJUSTMENT	15
SAMPLE SEED RATE CHARTS	19
CALIBRATION FORMULA	26
TRANSPORTATION	27
PRE-OPERATION CHECKLIST	27
OWNER SERVICE	28
OWNER SERVICE	28
TIGHTENING CULTIPACKER WHEEL ASSEMBLY	28
REMOVING CULTIPACKER SHAFT FROM FRAME	28
LUBRICATION INFORMATION	28
SERVICING TIRES SAFELY	29
CLEANING	30
ASSEMBLY	31
ASSEMBLY	31
DEALER SET-UP INSTRUCTIONS	31
OPTIONAL ACCESSORIES	31
DEALER CHECK LISTS	36
PARTS INDEX	37
APPENDIX	63
BOLT TORQUE CHART	63
BOLT SIZE CHART & ABBREVIATIONS	64
INDEX	65
REPAIR PARTS WARRANTY	66
PRODUCT WARRANTY	67



This Operator's Manual should be regarded as part of the machine. Suppliers of both new and second-hand machines must make sure that this manual is provided with the machine.



¡LEA EL INSTRUCTIVO!

Si no lee Ingles, pida ayuda a alguien que si lo lee para que le traduzca las medidas de seguridad.

SPECIFICATIONS

	PSS48	PSS60	PSS72	PSS84
Working Width	49.25"	60"	72"	84"
Overall Width (Maximum Configuration)	61.25"	72"	84"	96"
Spike Roller Pins	1/2" x 1-3/4"	1/2" x 1-3/4"	1/2" x 1-3/4"	1/2" x 1-3/4"
No. of Roller Pins (Front and Rear)	256	320	384	448
Front roller Positions	0-20° (7 positions)	0-20° (8 positions)	0-19° (9 positions)	0-17° (9 positions)
Front Disc Angle	0°,8°,12°,17°,23°	0°,6°,10°,14°,18°	0°,5°,8°,11°,15°	0°,4°,6°,10°,13°
Roller Diameter (Front and Rear)	8.6"	8.6"	8.6"	8.6"
Disc Diameter (Number)	16" notched (8)	16" notched (8)	18" notched (10)	18" notched (12)
Disc Spacing	7.5"	7.5"	7.5"	7.5"
Hitch	Cat I, II	Cat I, II	Cat I, II	Cat I, II
Quick Hitch compatible	Y	Y	Y	Y
Tractor HP Requirement	25-45 hp	30-65 hp	35-85 hp	40-125 hp
Weight - Studded Roller, Primary Box	779 lbs.	861 lbs.	1132 lbs.	1249 lbs.
Weight - Hunting Editions (Disc, Primary Box, Legume Box, Cast Iron Cultipacker)	1079 lbs.	1208 lbs.	1550 lbs.	1747 lbs.
Weight - All Boxes with Seed	1668 lbs.	1922 lbs.	2389 lbs.	2711 lbs.
Weight - Hunting Editions (Disc, Primary Box, Legume Box, Nylon Cultipacker)	968 lbs.	1064 lbs.	1369 lbs.	1535 lbs.
Primary Seedbox Capacity (bu)	4	5	6	7
Legume Seedbox Capacity (bu)	1	1.25	1.5	1.75
Native Seedbox Capacity (bu)	5	6.25	7.5	8.75
Seedcups/Picker wheels	7	8	10	12
Cultipacker Diameter (Number)	9" (22)	9" (26)	9" (32)	9" (37)
Calibration Tray	Standard	Standard	Standard	Standard
Seed Distribution Method	Broadcast drop with wind deflector tray	Broadcast drop with wind deflector tray	Broadcast drop with wind deflector tray	Broadcast drop with wind deflector tray

GENERAL INFORMATION

The purpose of this manual is to assist you in operating and maintaining your Precision Super Seeder. Read it carefully. It furnishes information and instructions that will help you achieve years of dependable performance. These instructions have been compiled from extensive field experience and engineering data. Some information may be general in nature due to unknown and varying operating conditions. However, through experience and these instructions, you should be able to develop procedures suitable to your particular situation.

The illustrations and data used in this manual were current at the time of printing but, due to possible inline production changes, your machine may vary slightly in

detail. We reserve the right to redesign and change the machines as may be necessary without notification.

WARNING

■ **Precision Super Seeder should never be operated with any safety shielding removed.**

Throughout this manual, references are made to right and left direction. These are determined by standing behind the equipment facing the direction of forward travel.

4 Introduction

(Rev. 4/24/2018)
MAN0988 (11/5/2012)



SAFETY RULES

ATTENTION! BECOME ALERT! YOUR SAFETY IS INVOLVED!



Safety is a primary concern in the design and manufacture of our products. Unfortunately, our efforts to provide safe equipment can be wiped out by an operator's single careless act.

In addition to the design and configuration of equipment, hazard control and accident prevention are dependent upon the awareness, concern, prudence, and proper training of personnel involved in the operation, transport, maintenance, and storage of equipment.

It has been said, "The best safety device is an informed, careful operator." We ask you to be that kind of operator.

TRAINING

■ Safety instructions are important! Read all attachment and power unit manuals; follow all safety rules and safety decal information. (Replacement manuals and safety decals are available from your dealer. To locate your nearest dealer, check the Dealer Locator at www.WoodsEquipment.com, or in the United States and Canada call 1-800-319-6637.) Failure to follow instructions or safety rules can result in serious injury or death.

■ If you do not understand any part of this manual and need assistance, see your dealer.

■ Know your controls and how to stop engine and attachment quickly in an emergency.

■ Operators must be instructed in and be capable of the safe operation of the equipment, its attachments, and all controls. Do not allow anyone to operate this equipment without proper instructions.

■ Never allow children or untrained persons to operate equipment.

PREPARATION

■ Check that all hardware is properly installed. Always tighten to torque chart specifications unless instructed otherwise in this manual.

■ Always wear relatively tight and belted clothing to avoid getting caught in moving parts. Wear sturdy, rough-soled work shoes and protective equipment for eyes, hair, hands, hearing, and head; and respirator or filter mask where appropriate.

■ Make sure attachment is properly secured, adjusted, and in good operating condition.

■ Make sure all safety decals are installed. Replace if damaged. (See Safety Decals section for location.)

■ A minimum 20% of tractor and equipment weight must be on the tractor front wheels when attachments are in transport position. Without this weight, front tractor wheels could raise up resulting in loss of steering. The weight may be attained with front wheel weights, ballast in tires, front tractor weights or front loader. Weigh the tractor and equipment. Do not estimate.

OPERATION

■ Keep bystanders away from equipment.

■ Do not operate or transport equipment while under the influence of alcohol or drugs.

■ Install Lighting Kit 604387 when this equipment obscures the tractor's tail lamps or stop lamps.

■ Operate only in daylight or good artificial light.

■ Keep hands, feet, hair, and clothing away from equipment while engine is running. Stay clear of all moving parts.

■ Always comply with all state and local lighting and marking requirements.

■ Never allow riders on power unit or attachment.

■ Power unit must be equipped with ROPS or ROPS cab and seat belt. Keep seat belt securely fastened. Falling off power unit can result in death from being run over or crushed. Keep foldable ROPS system in "locked up" position at all times.

■ Always sit in power unit seat when operating controls or starting engine. Securely fasten seat belt, place transmission in neutral, engage brake, and ensure all other controls are disengaged before starting power unit engine.

■ Look down and to the rear and make sure area is clear before traveling in reverse.

■ Do not operate seeder in reverse.

■ Use extreme care when working close to fences, ditches, other obstructions, or on hillsides.

■ Do not operate or transport on steep slopes.

■ Do not stop, start, or change directions suddenly on slopes.

■ Use extreme care and reduce ground speed on slopes and rough terrain.

■ Watch for hidden hazards on the terrain during operation.

■ Stop power unit and equipment immediately upon striking an obstruction. Turn off engine, remove key, inspect, and repair any damage before resuming operation.

SAFETY RULES



ATTENTION! BECOME ALERT! YOUR SAFETY IS INVOLVED!



TRANSPORTATION

- The maximum travel speed is the lesser of
 - The limit of the road conditions;
 - The maximum specified ground speed;
 - For towing operations as indicated in the operator's manual or SIS;
 - For the towed vehicle as indicated in its operator's manual, SIS, or information sign;
- The maximum ground speed of the towed equipment combination shall be limited to the lowest specified ground speed of any of the towed machines. This speed is the ground speed limitation.

EXAMPLE: If the tractor is capable of 40 km/h, the first implement has a SIS for 30 km/h, and the last implement's operator's manual states its specified ground speed is 25 km/h, the towed equipment combination ground speed limitation is 25 km/h.
- Use additional caution and reduce speed when under adverse surface conditions, turning, or on inclines.
- A minimum 20% of tractor and equipment weight must be on the tractor front wheels when attachments are in transport position. Without this weight, front tractor wheels could raise up resulting in loss of steering. The weight may be attained with front wheel weights, ballast in tires, front tractor weights or front loader. Weigh the tractor and equipment. Do not estimate.
- Do not operate or transport on steep slopes. Refer to tractor manual for proper ballasting and slope recommendations.
- Do not operate or transport equipment while under the influence of alcohol or drugs.
- Always comply with all state and local lighting and marking requirements. Turn on flashing warning lights whenever traveling on a public roadway.
- Never allow riders on power unit or attachment.
- Install Lighting Kit 604387 when this equipment obscures the tractor's tail lamps or stop lamps.
- Always raise unit and install transport lock before transporting. Leak down or failure of mechanical or hydraulic system can cause equipment to drop.
- Always attach safety chain to tractor drawbar when transporting unit.

■ The maximum transport speed for this machine is 20 mph (30 km/h). Regardless of the maximum speed capability of the towing tractor, do not exceed the implement's maximum transport speed. Doing so could result in:

- Loss of control of the implement and tractor
- Reduced or no ability to stop during braking
- Implement tire failure
- Damage to the implement or its components.

MAINTENANCE

- Before dismounting power unit or performing any service or maintenance, follow these steps: disengage power to equipment, lower the 3-point hitch and all raised components to the ground, operate valve levers to release any hydraulic pressure, set parking brake, stop engine, remove key, and unfasten seat belt.
- **NEVER GO UNDERNEATH EQUIPMENT.** Never place any part of the body underneath equipment or between moveable parts even when the engine has been turned off. Hydraulic system leak-down, hydraulic system failures, mechanical failures, or movement of control levers can cause equipment to drop or rotate unexpectedly and cause severe injury or death.
 - Service work does not require going underneath.
 - Read Operator's Manual for service instructions or have service performed by a qualified dealer.
- Always wear relatively tight and belted clothing to avoid getting caught in moving parts. Wear sturdy, rough-soled work shoes and protective equipment for eyes, hair, hands, hearing, and head; and respirator or filter mask where appropriate.
- Make sure attachment is properly secured, adjusted, and in good operating condition.
- Keep all persons away from operator control area while performing adjustments, service, or maintenance.
- Tighten all bolts, nuts, and screws to torque chart specifications. Check that all cotter pins are installed securely to ensure equipment is in a safe condition before putting unit into service.
- Make sure all safety decals are installed. Replace if damaged. (See Safety Decals section for location.)



SAFETY RULES

ATTENTION! BECOME ALERT! YOUR SAFETY IS INVOLVED!



STORAGE

- Block equipment securely for storage.
- Keep children and bystanders away from storage area.

SAFETY & INSTRUCTIONAL DECALS



ATTENTION! BECOME ALERT! YOUR SAFETY IS INVOLVED!



Replace Immediately If Damaged!

BE CAREFUL!

Use a clean, damp cloth to clean safety decals.

Avoid spraying too close to decals when using a pressure washer; high-pressure water can enter through very small scratches or under edges of decals causing them to peel or come off.

Replacement safety decals can be ordered free from your Woods dealer. To locate your nearest dealer, check the Dealer Locator at www.WoodsEquipment.com, or in the United States and Canada call 1-800-319-6637.

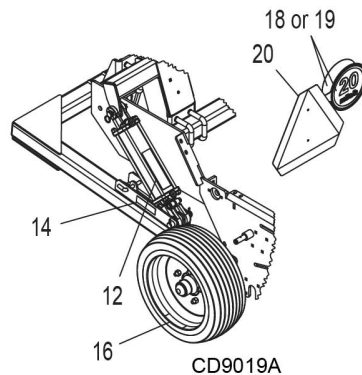
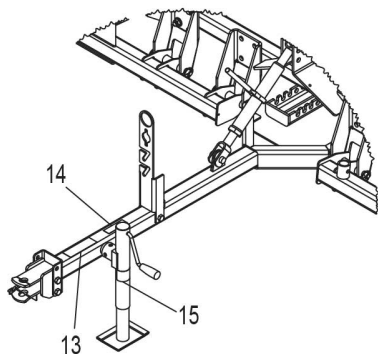
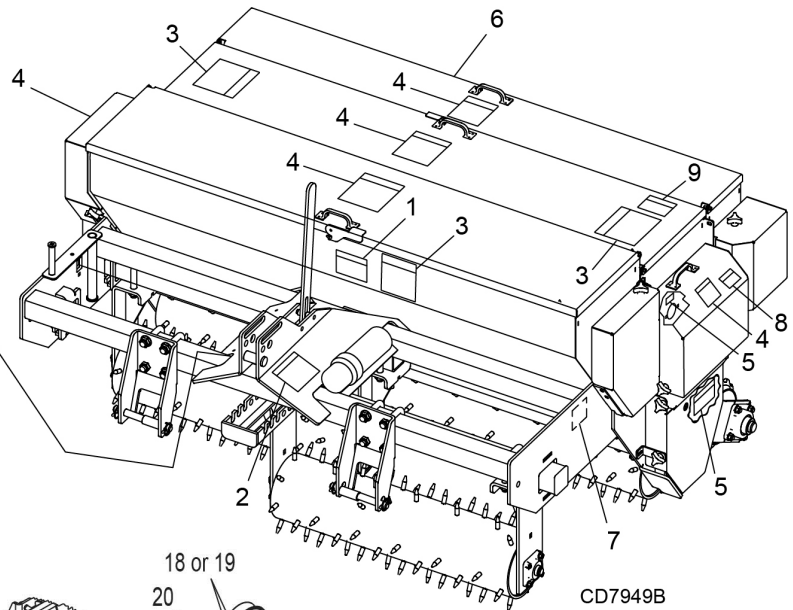
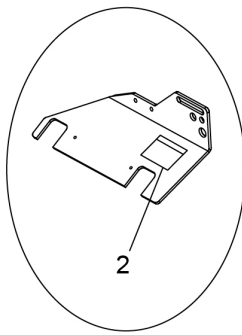
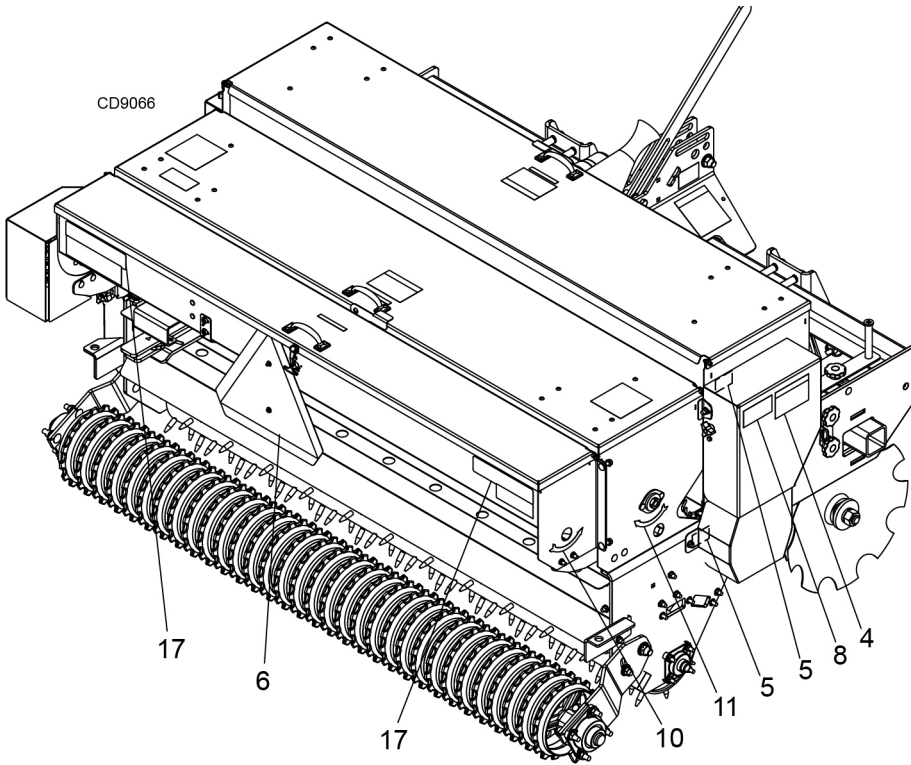

(Safety Decals continued on next page)



SAFETY & INSTRUCTIONAL DECALS

ATTENTION! BECOME ALERT! YOUR SAFETY IS INVOLVED!
Replace Immediately If Damaged!



(Safety Decals continued from previous page)

1 - PN 55121

WARNING	
	<p>FALLING OFF CAN RESULT IN BEING RUN OVER.</p> <ul style="list-style-type: none"> Tractor must be equipped with ROPS (or ROPS CAB) and seat belt. Keep foldable ROPS systems in "locked up" position at all times. Buckle Up! Keep seat belt securely fastened. Allow no riders.
	<p>RAISED IMPLEMENT CAN DROP AND CRUSH.</p> <ul style="list-style-type: none"> Never go underneath raised implement which can drop from equipment or tractor 3-point hitch hydraulic leak down, hydraulic system failures, movement of control levers or mechanical linkage failures. Service work does not require going underneath implement. Read manual instructions.
	<p>FALLING OFF OR GOING UNDERNEATH IMPLEMENT CAN RESULT IN SERIOUS INJURY OR DEATH.</p> <p style="text-align: right;"><small>55121-C</small></p>

2 - PN 1003751

WARNING	
<p>CRUSHING AND PINCHING HAZARD</p> <ul style="list-style-type: none"> Be extremely careful handling various parts of the machine. They are heavy and hands, fingers, feet, and other body parts could be crushed or pinched between tractor and implement. Operate tractor controls from tractor seat only. Do not stand between tractor and implement when tractor is in gear. Make sure parking brake is engaged before going between tractor and implement. Stand clear of machine while in operation or when it is being raised or lowered. <p>FAILURE TO FOLLOW THESE INSTRUCTIONS COULD RESULT IN SERIOUS INJURY OR DEATH.</p> <p style="text-align: right;"><small>1003751</small></p>	

3 - PN 55122

WARNING	
<p>TO AVOID SERIOUS INJURY OR DEATH:</p> <ul style="list-style-type: none"> Read Operator's Manual before operating, servicing or repairing equipment. Follow all safety rules and instructions. (Manuals are available from dealer or call 1-800-319-6637.) Operate from tractor seat only. Lower equipment to ground, stop engine, remove key and set brake before dismounting tractor. Never allow children or untrained persons to operate equipment. Never allow riders. Keep bystanders away from equipment during operation. Keep all shields in place and in good condition. Do not transport towed or semi-mounted units over 20 mph. <p>FAILURE TO FOLLOW THESE INSTRUCTIONS CAN RESULT IN INJURY OR DEATH.</p> <p style="text-align: right;"><small>55122-D</small></p>	

4 - PN 15502

WARNING	
<p>ROTATING COMPONENTS</p> <p>Do not operate without cover in place. Look and listen for rotation. Do not open cover until all components have stopped.</p> <p>CONTACT WITH ROTATING PARTS CAN CAUSE SERIOUS INJURY.</p> <p style="text-align: right;"><small>15502</small></p>	

5 - PN 18868

DANGER	
<p>SHIELD MISSING</p> <p>DO NOT OPERATE</p> <p>PUT SHIELD ON</p> <p style="text-align: right;"><small>18868-B</small></p>	

7 - Serial Number Plate

<p>Model #</p> <p>Serial #</p> <p>(BAR CODE)</p>
Woods Equipment Company Oregon, Illinois 61061 USA

8 - PN 1034504

SHIELD RETAINER KNOB STORAGE	
<p>TO SERVICE COMPONENTS GUARDED BY SHIELDS:</p> <ul style="list-style-type: none"> Remove knob. Lift shield for access to service components. Return knob to original location for storage during service. Reverse procedure before returning unit to operation. <p style="text-align: right;"><small>1034504</small></p>	

9 - PN 1041910

NOTICE	
<p>If required by state and local lighting and marking regulations, contact your dealer to obtain an accessory light kit.</p> <p style="text-align: right;"><small>1041910</small></p>	

(Safety Decals continued on next page)



SAFETY & INSTRUCTIONAL DECALS

ATTENTION! BECOME ALERT! YOUR SAFETY IS INVOLVED!

Replace Immediately If Damaged!



(Safety Decals continued from previous page)

12 - PN W19924

 <p style="font-size: small; margin-top: 5px;">W19924</p>	⚠ WARNING
<p>HIGH-PRESSURE HYDRAULIC OIL LEAKS CAN PENETRATE SKIN RESULTING IN SERIOUS INJURY, GANGRENE OR DEATH.</p> <ul style="list-style-type: none"> ■ Check for leaks with cardboard; never use hand. ■ Before loosening fittings: lower load, release pressure, and be sure oil is cool. ■ Consult physician immediately if skin penetration occurs. 	

10 - PN W5669

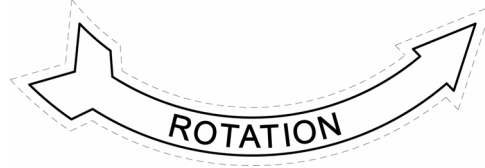

13 - PN 614738

⚠ WARNING	
	<p>Do not exceed this implement's maximum transport speed of 32 km/h (20 mph). Exceeding this speed may result in loss of control during transport or braking and serious injury or death.</p> <p>Transport only with a properly ballasted tractor and a properly attached tow chain. Do not transport with a motor vehicle. Reduce speed and use additional caution when on inclines, towing under adverse surface conditions, and turning.</p> <p style="font-size: x-small; text-align: right;">614738</p>

11 - PN 12777

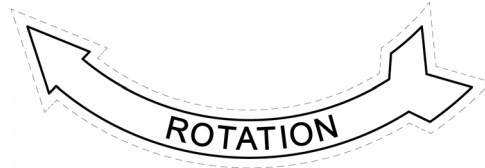

14 - PN 614737

⚠ WARNING	
TO AVOID INJURY INSTALL CYLINDER LOCKUP(S) BEFORE TRANSPORTING OR SERVICING MACHINE	
614737	

6 - PN 24611

Slow Moving Vehicle

17 - PN 20106

Red Reflector 2 x 4.5
(PSS48 & PSS60 seeders)

PN 57123

Red Reflector 2 x 9
(PSS72 & PSS84 seeders)

15 - Certified Jack Label

<p>STATIC CAPACITY: 2000 LBS DYNAMIC CAPACITY: 1200 LBS SIDE TORQUE CLASS: CLASS IV MANUFACTURER ID: ITI SERIAL #: XXXXX.XXX</p>
--

18 - PN 611520



16 - PN 1006348

⚠ WARNING	EXPLOSION HAZARD
<p>RELEASE ALL AIR PRESSURE BEFORE LOOSENING BOLTS. FAILURE TO DO SO COULD RESULT IN SERIOUS INJURY OR DEATH. MAX. SPEED: 20 MPH, MAX. WEIGHT: 4000 LBS., MAX. AIR PRESSURE: 40 PSI.</p>	
1006348	

19 - PN 611521 - SIS 30 KM/H

20 - PN 24611 - Slow Moving Vehicle

OPERATION

The operator is responsible for the safe operation of this seeder. The operator must be properly trained. Operators should be familiar with the equipment, the tractor, and all safety practices before starting operation. Read the safety rules and safety decals on page 5 through page 9.

Recommended tractor ground speed is from 2 to 5 mph.

WARNING

■ Power unit must be equipped with Roll Over Protection System (ROPS) or ROPS cab and seat belt. Keep seat belt securely fastened. Falling off power unit can result in death from being run over or crushed. Keep foldable ROPS system in “locked up” position at all times.

■ Never allow children or untrained persons to operate equipment.

■ Keep bystanders away from equipment.

■ Keep hands, feet, hair, and clothing away from equipment while engine is running. Stay clear of all moving parts.

CAUTION

■ Stop power unit and equipment immediately upon striking an obstruction. Turn off engine, set parking brake, remove key, inspect, and repair any damage before resuming operation.

■ Always wear relatively tight and belted clothing to avoid getting caught in moving parts. Wear sturdy, rough-soled work shoes and protective equipment for eyes, hair, hands, hearing, and head; and respirator or filter mask where appropriate.

Precision Super Seeder Ground Tool Operation

The Precision Super Seeder is an excellent turf reconditioning tool, primary seeder, food plot and conservation seeder. Its ground penetration promotes a healthy root system by allowing water, air, and sunlight to enter the roots.

Front Rollers

When the front rollers are straight (Figure 1) and the seeder is pulled forward, the large front pins will penetrate the soil in a straight pushing action, and little disturbance is caused to the turf.

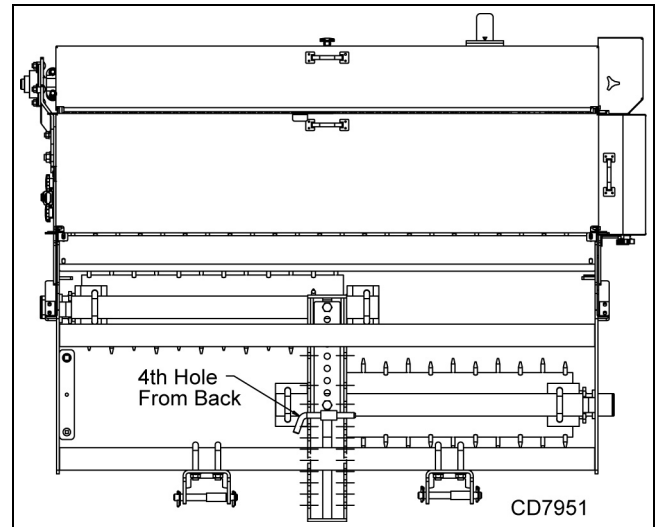

Figure 1. Front Roller in Straight Position - Top View (mast plates hidden for picture clarity) (72" Seeder Shown)

The front rollers can be angled to promote a more aggressive tearing action of the turf. The more the angle, the more tearing action is applied by the front roller pins. For severe turf conditions, the maximum angle position may be desired (Figure 2).

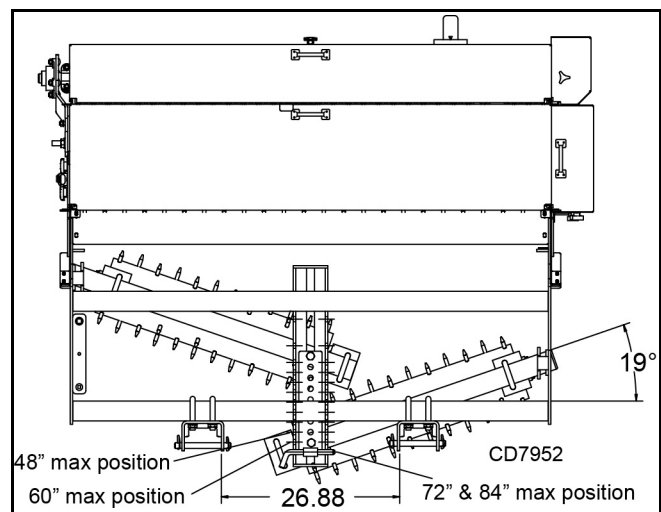

Figure 2. Maximum Front Roller Position - Top View (mast plates hidden for picture clarity) (72" Seeder Shown)

Front Disc

The front disc tool can be used to prepare a seedbed without the need for a separate disc or tillage tool used ahead of time. When the discs are straight, the seeder has little soil disturbance. When the discs are angled fully backward, there is maximum soil disturbance and the seedbed can be prepared usually in one or two passes. The disc has four angled positions to provide an array of soil penetration depths and seedbed preparation.

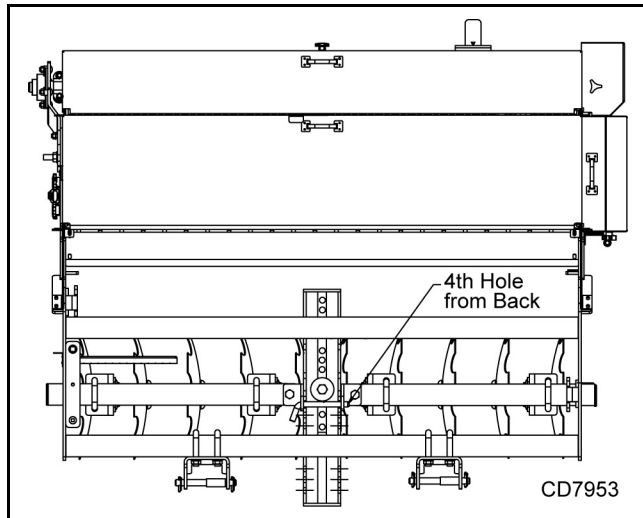

Figure 3. Disc in Straight Position (mast plates hidden for picture clarity) (72" Seeder Shown)

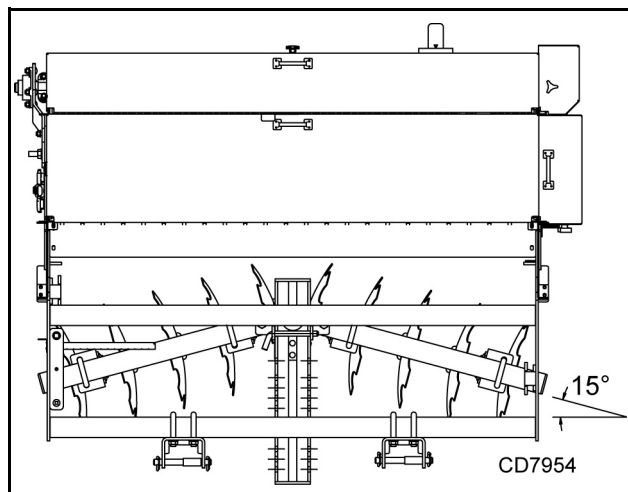

Figure 4. Disc in Angled Position (mast plates hidden for picture clarity) (72" Seeder Shown)

IMPORTANT

■ Do not operate seeder in reverse. Operating seeder in reverse may result in damage to seed boxes and chain drive system.

Chain Drive Disconnect

The Precision Super Seeder seed boxes can be engaged or disengaged so that any one seed box or all seed boxes can be operative or inoperative. See Figures 5 and 20 for disconnect locations. It is not recommended to run the plastic seed cup assemblies without seed being metered.

It may be necessary to make several passes with the ground engaging tools before planting seed. Disengaging the seed box chain drive will allow the soil bed to be prepared without planting seed or running the plastic seed cup assemblies in a dry state.

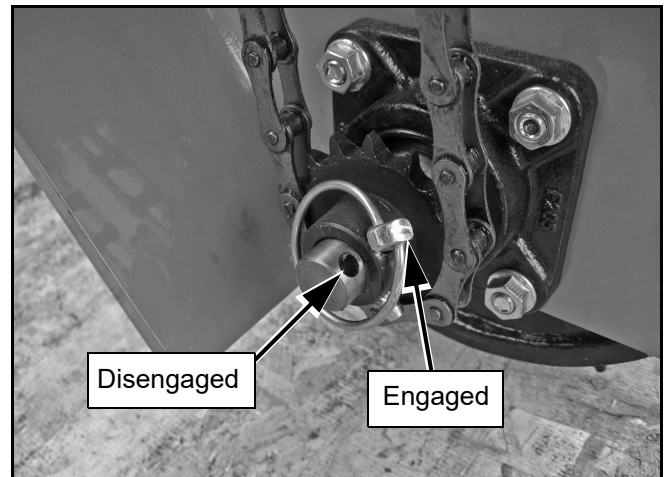

Figure 5. Chain Drive Disconnect

Rear Roller

The rear roller firms and presses soil kicked up by the front tillage tool. This creates a uniform seedbed with the loose soil necessary for ensuring proper seed germination. See Figure 17.

When the situation permits, making a second pass 90-degrees to the first is an effective way for the roller pins to penetrate areas where uneven soil conditions exist.

In extremely compacted soil conditions, add extra weight to the seeder to help the roller pins penetrate the turf and soil sufficiently.

Operation

The power for operating the seeder comes from contact between the seeder rear roller and the turf.

Know how to stop the tractor and seeder quickly in an emergency.

Survey the area to be worked and remove any obstructions that may affect the performance of the equipment.

Tractor Stability

WARNING

■ A minimum 20% of tractor and equipment weight must be on the tractor front wheels when attachments are in transport position. Without this weight, front tractor wheels could raise up resulting in loss of steering. The weight may be attained with front wheel weights, ballast in tires, front tractor weights or front loader. Weigh the tractor and equipment. Do not estimate.

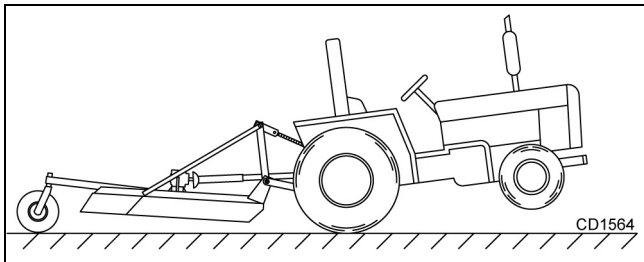

Figure 6. Tractor Stability

ATTACHING PRECISION SUPER SEEDER TO TRACTOR (3-POINT HITCH)

NOTE: The Precision Super Seeder is designed for use on Category I and II, 3-point hitch tractors. See page 4 for specifications.

NOTE: For Category II fixed hitch usage, remove Quick Hitch 3/4" bolt, nut and sleeve to prevent damage to tractor's 3-point top link.

1. Attach the tractor's lower lift arms to the seeder and secure with mounting pins and klik pins. See Figure 7, 8 and 9.
2. Attach the tractor's top link to the mast plates of the seeder. For controlled depth of tillage, use the fixed-pin location above the quick hitch bushing. See Figure 7, 8 and 9.
3. To enable the seeder to follow the contours of uneven ground, install the tractor's top link in the long slot in the top of the mast plates. For proper float (up and down) the top link pin should be centered in the slot (recommended for beginners).
4. For quick hitch use, install the available quick hitch bushings. The seeder will not float with a quick hitch installed.
5. Adjust the lower lift arm anti-sway device to prevent excessive side-to-side movement of the seeder.

NOTE: The seeder can be operated in a float or fixed 3-point hitch position. For beginning usage, the float position is recommended. See Figure 7.

NOTE: An optional Quick Hitch Bushing, P/N 1002012 is available.

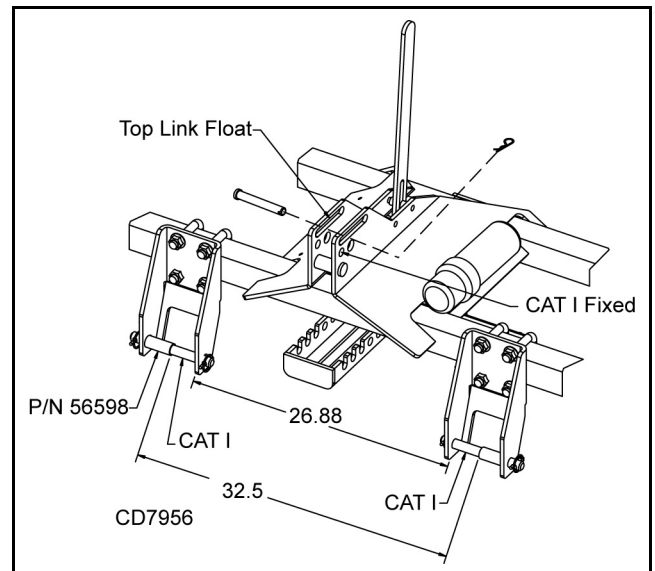

Figure 7. CAT I Hitch

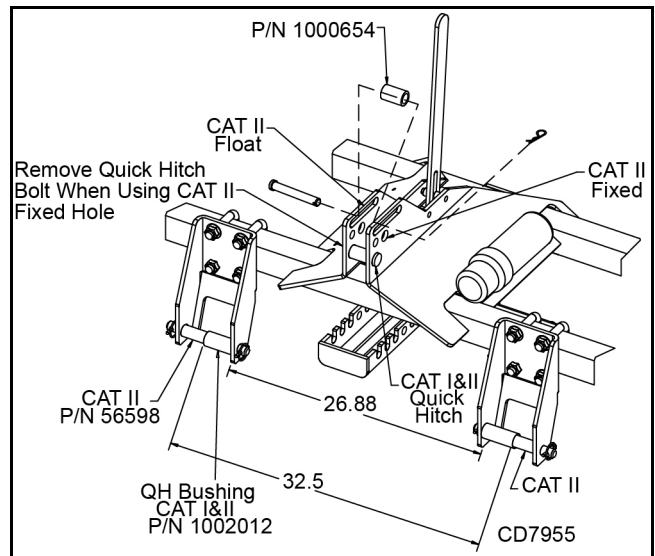

Figure 8. CAT I Quick Hitch and CAT II Hitch

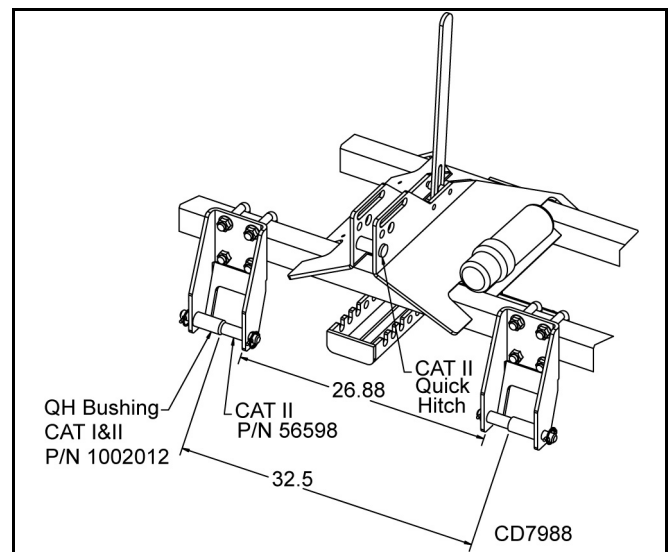

Figure 9. CAT II Quick Hitch

HITCHING PRECISION SUPER SEEDER TO TRACTOR WITH TOW KIT

■ Make sure shields and guards are properly installed and in good condition. Replace if damaged.

1. Park seeder and tractor on a level, hard-surfaced area.
2. Adjust clevis hitch bracket on tow kit tongue so it is level when attached to tractor.
3. Adjust the parking jack to match tow kit tongue height to the tractor drawbar height.
4. Pin the tongue to the tractor drawbar.

NOTICE: When attaching seeder to tractor drawbar, make sure the correct drawbar pin is used. A Category 1 drawbar is 1"; Category 2 is 1.25". Failure to use the correct pin size will result in premature wear of hitch and drawbar hole. If the hitch on the seeder doesn't match your tractor drawbar, contact your dealer to order the correct size hitch for your tractor. If seeder will be attached to tractor for a long period of time, secure hitch to drawbar using a bolt, lock nut, and washers tightly assembled. This will reduce wear on drawbar and hitch.

5. Attach the safety chain to the tractor as shown in Figure 10. Limit chain slack to only what is needed for turning. Be sure to lock hook securely.

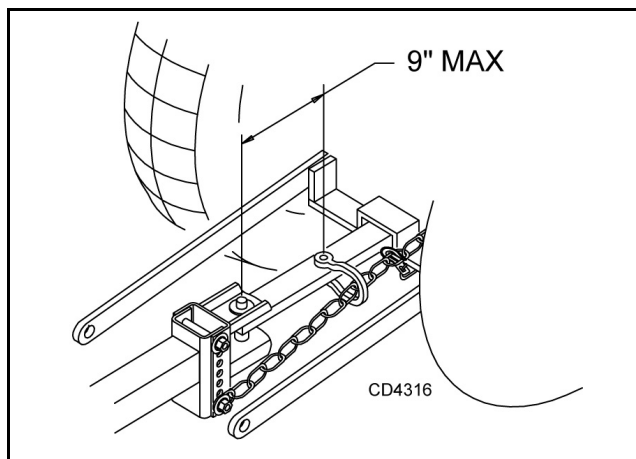

Figure 10. Tow Chain Installation

6. Lower the parking jack until the tongue weight is fully supported by the drawbar and the jack foot is off the ground. Unpin the jack from the tongue.
7. Pin the jack to the storage tube on the top of the left wheel arm. This location prevents accidental contact from the rear tractor tire, which could result in damage to the jack. See Figure 11.

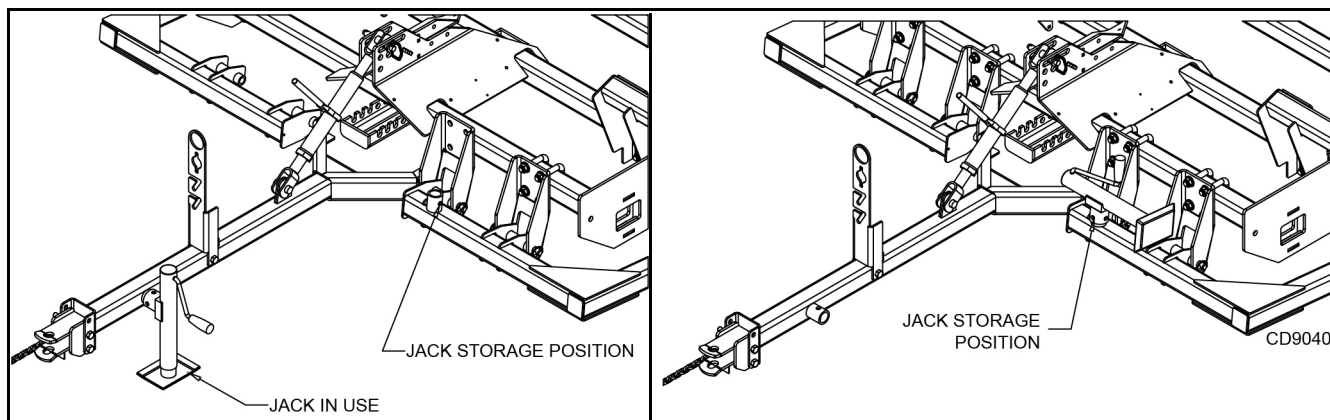

Figure 11. Jack Positions

Attaching Hydraulic Hoses

1. Attach the hydraulic hoses from the seeder to the tractor.
2. Route the hoses through the hose guide of the tow kit tongue and be sure the hoses can slide freely in the guide.
3. From the operator position, start the tractor and raise and lower the seeder several times. This will purge the hydraulic cylinders and hoses of trapped air.

Interference Check

1. Be sure that the tractor 3-point arms do not interfere with hydraulic hoses or tow kit components.
2. Check for straight ahead operation and full turning angles. If there is any interference, remove the 3-point arms.

NOTICE: Contact between 3-point arms and seeder can cause damage, especially when turning.

PRECISION SUPER SEEDER ATTITUDE ADJUSTMENT

The Precision Super Seeder can be used as both a tillage tool and a seeding tool. When used strictly as a tillage tool, a nose-down attitude will provide the most aggressive tillage. When used for tillage and seeding at the same time, a level attitude is preferable. If the Precision Super Seeder is used to seed tilled soil, a slight nose-up attitude may be preferable for minimum soil disturbance. While the seeder is connected to the tractor, follow these instructions to make attitude adjustments to the seeder:

Nose - Down Attitude Adjustment

3-Point Mounted

1. Lower the seeder to the ground.
2. Pin the tractor top link into the appropriate fixed top link hole (Cat 1 or 2).
3. Shorten the tractor top link length until the drive roller has been lifted off the ground equivalent to the desired tillage depth. Fix the top link length by tightening the jam nut on the top link.
4. Resume operation and check performance. Repeat as necessary.

Drawbar Mounted

1. Raise seeder to full height and secure with transport locks. Measure the front tool height from the ground (disc blades or spiked rollers).
2. Rotate tongue ratchet jack clockwise to adjust attitude forward. Measure front tool height again for increased tillage depth.
3. Fix ratchet jack length by tightening the jam nut. Release transport locks and resume operation. Check performance and repeat as necessary.

Nose - Up Attitude Adjustment

3-Point Mounted

1. Lower the seeder to the ground.
2. Pin the tractor top link into the appropriate fixed top link hole (CAT 1 or 2).
3. Lengthen the tractor top link length until the front tool (disc blades or spiked rollers) has been lifted off the ground a sufficient distance. Fix the top link length by tightening jam nut on the top link.

4. Resume operation and check performance. Repeat as necessary.

Drawbar Mounted

1. Raise seeder to full height and secure with transport locks. Measure the front tool height from the round (disc blades or spiked rollers).
2. Rotate tongue ratchet jack counter-clockwise to adjust attitude rearward. Measure front tool height again for decreased tillage depth.
3. Fix ratchet jack length by tightening the jam nut. Release transport locks and resume operation. Check performance and repeat as necessary.

NOTICE

■ **Excessive forward or rear attitude adjustment will lead to poor performance and may cause equipment damage or premature bearing failure.**

Adjust Front Roller Angle

1. Position tractor and Precision Super Seeder on a level surface.
2. Set seeder on the ground and set parking brake.
3. Remove bent pin and hair pin clip from the front of seeder (see Figure 12).
4. Place wooden blocks (minimum 4" thickness) on ground to align with each end of Precision Super Seeder.

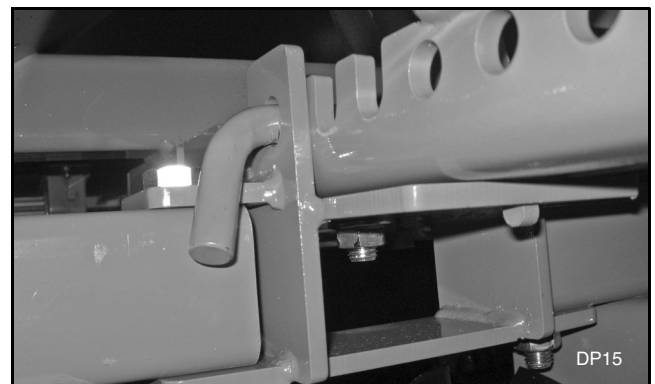

Figure 12. Bent Pin and Lock Assembly - Disc Slide

5. Raise the seeder slightly off the ground and position over wooden blocks by moving tractor. Do not allow wooden block to contact the front roller (see Figure 13.)

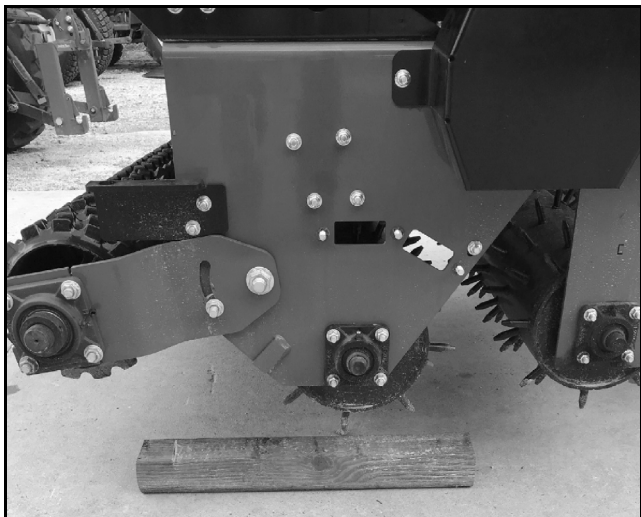

Figure 13. Precision Super Seeder above Wooden Blocks

6. Lower seeder to resting position on wooden blocks for support during front roller adjustment. (Follow tractor safe parking procedure in tractor operator's manual).
7. Raise the adjustment handle and pivot it to the next adjustment hole (see Figure 15). Move handle rearward; front rollers will start to angle forward. Continue this process until front rollers have the desired angle and holes align between frame rail and roller side weldment.
8. Partially engage bent pin to hold adjusted position.
9. Lift seeder and pull forward to clear wooden blocks. Lower seeder to rest position on the ground/level surface, and fully install bent pin and hair pin clip (see Figure 14).



Figure 14. Bent Pin Installation

10. Reverse this procedure to move front roller back into straight position.

NOTICE: The 72" and 84" seeders use the front notch of the frame rail for the maximum roller angle (19° and 17° respectively). The 60" seeder uses the 2nd notch from the front for the maximum roller angle (20°). The 48" seeder uses the 3rd notch from the front for the maximum roller angle (20°).

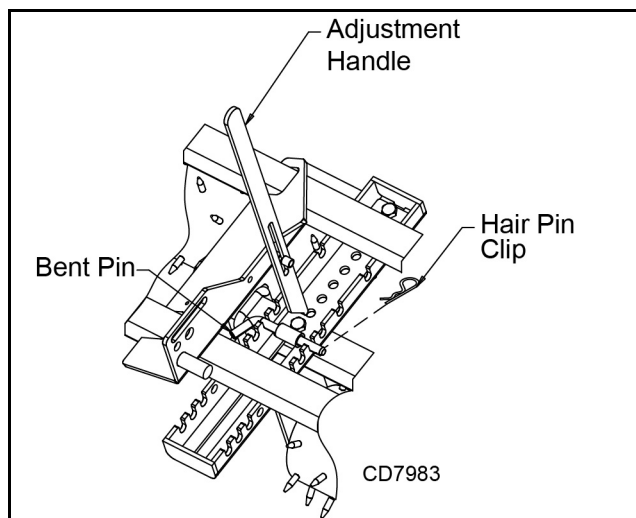

Figure 15. Spike Roller Handle Adjustment (most plate hidden for picture clarity)

Adjust Front Disc Angle

1. Position tractor and Precision Super Seeder on a level surface.
2. Set seeder on the ground and set parking brake.
3. Remove bent pin and hair pin clip from front of seeder (see Figure 12).
4. Place wooden blocks (minimum 4" thickness) on ground to align with each end of the Precision Super Seeder.
5. Raise seeder slightly off the ground and position seeder over wooden blocks by moving tractor. Do not allow wooden block to contact the front disc gang (see Figure 13.)
6. Lower seeder to resting position on wooden blocks for support during front disc adjustment. (Follow tractor safe parking procedure in tractor operator's manual.)
7. Raise the adjustment handle and pivot it to the next adjustment role (see Figure 15). Move handle forward; front discs will start to angle rearward. Continue this process until front discs have the desired angle and holes align between from rail and disc slide weldment.
8. Partially engage bent pin to hold adjusted position.
9. Lift seeder and pull forward to clear wooden blocks. Lower seeder to rest position on the ground/level surface, and fully install bent pin and hair pin clip (see Figure 14).

10. Reverse this procedure to move front disc back into straight position.

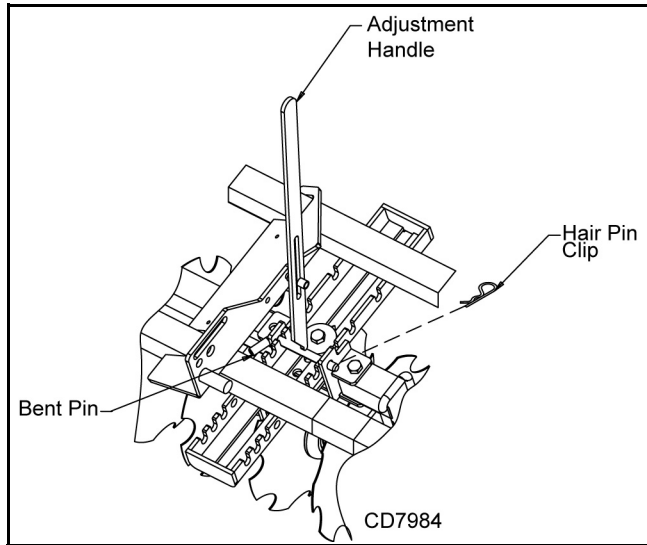

Figure 16. Disc Handle Adjustment (mast plate hidden for picture clarity)

Seed Box/Types of Seeds

NATIVE	Big Blue Stem, Brome, Indian, Little Blue Stem, Side Oats Grama
PRIMARY	Annual Rye Grass, Barley, Kentucky Blue Grass Blends, Fescue, Oats, Orchard Grass, Perennial Rye Grass, Snow Peas, Sorghum, Soybeans, Sunflower, Sudan, Wheat
LEGUME	Alfalfa, Bahai, Bermuda, Birdsfoot Tree Foil, Brassica, Buckwheat, Carpet Grass, Centipede Grass, Chicory, Clover, Fescue, Forb, Kentucky Blue Grass, Radishes, Rape, Sudan, Switch Grass, Timothy, Turnip

Seeding Operation

The Precision Super Seeder is capable of planting a wide variety of seeds over a wide range of seeding rates. The Precision Super Seeder is available with up to three different seed boxes. To determine which seed box is best for seeding, consider the size of the seed, planting depth and shape of the seed.

The Primary seed box has a fluted roller seed cup with an adjustable concave. The seed cup is capable of planting large seeds including soybeans, grass seeds, and small legume seeds. The seed cup metering is adjustable with a common shaft and lever. As the seed shaft is moved axially more or less of the fluted seed roller is exposed changing the seed metering. See Figure 21. Additional rates can be achieved by changing the drive sprocket. The concave will need to be opened

as the size of the seed increases. Opening the concave ever further will also increase the seed rate. Seed from the Primary seed box is dropped in front of the rear roller. As the seed hits the roller it is dispersed and diverted forward of the roller. The roller then pushes the seed and soil down creating a firm seed bed with optimal seed to soil contact.

Seed stop plates, see Figure 17, are available as an accessory to increase row width/reduce seeding rate. Place the seed stop plate over the seed cup hole as shown. The shape of the plate creates a tight fit.

NOTICE: When installing the seed stop plates, use a hammer to center the agitator shaft roll pins to prevent interference.

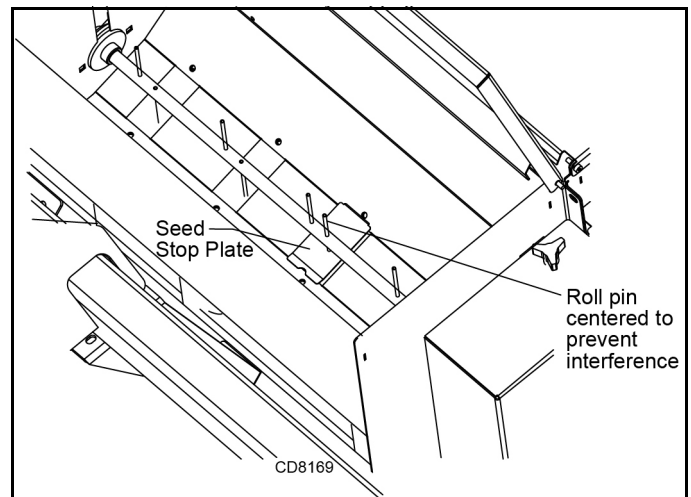

Figure 17. Seed Stop Plates

The Legume seed box has a small seed cup and adjustable fluted roller. The lever and shaft are adjustable similarly to the Primary seed box. See Figure 24. The Legume seed box is ideal for planting alfalfa, clover, forbes, rape and other small seeds. The seed meter tubes attached to the Legume box can divert seed to the primary transition tray for a deeper planting depth or in front of the optional cultipacker for shallower depths.

The Native prairie seed box is suitable for planting long stemmed prairie seeds not capable of being planted in the Primary and Legume seed boxes. Big Blue Stem, Little Blue Stem, Brassica and Indian grass can be planted with this seed box. The seed box chain drive comes equipped with a set of derailleur chain sprockets to provide three different speeds. The chain drive idler can be moved to a different chain drive position by rearranging the idler spacers. Seed from the Native seed box is placed ahead of the rear spiked roller for dispersion of seed and incorporation into the seed bed.

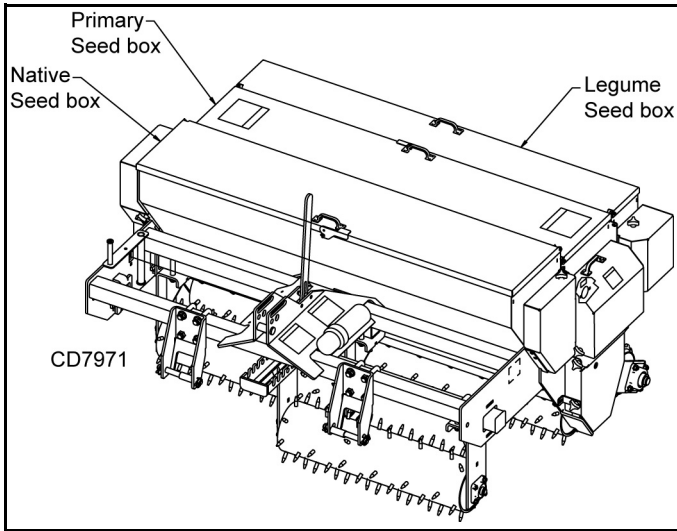

Figure 18. Seed Boxes

IMPORTANT

■ Do not operate seeder in reverse. Operating seeder in reverse may result in damage to seed boxes and chain drive system.

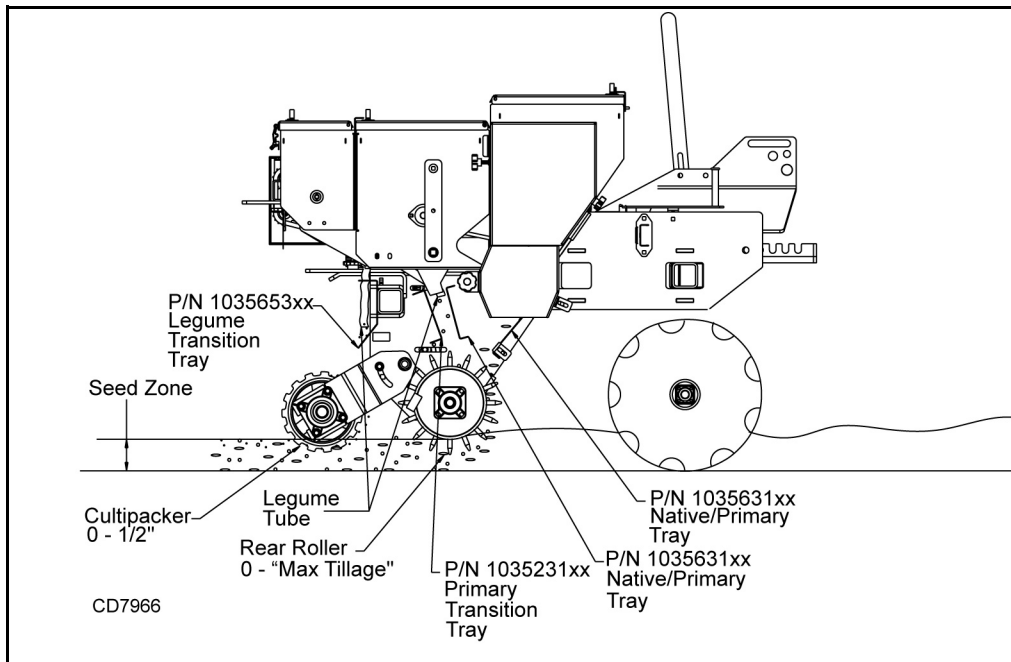

Figure 19. Transition Trays

Filling the Seed Box

1. Calibrate seeder and set seed cup rate adjustment and concaves to the correct position. Start with the seed cup at a fully closed position and open the seed cup to the desired fluted roller opening.

NOTICE: The seed cup can be opened further with seed, but closing the seed cup or concave when full of seed could result in seed cup damage. If the

seed cup must be restricted with seed in the seed box, place a piece of cardboard over the seed cup opening and remove seed in the seed cup by opening the concave or rotating the seed shaft and then closing the seed cup.

2. Open the seed box cover and rotate the brace to hold the cover up while filling the seed box. Place

brace point in the covers spill guard notch. See Figure 20.

4. Lift brace and rotate to storage position. Close seed cover and engage cover latch.

3. Place seed in the seed box.

SAMPLE SEED RATE CHARTS (STANDARD CHAIN DRIVE)

NOTICE: For chain drives other than the standard drive, refer to the conversion charts for the multiplier to convert the application rate to the correct value.

Cool Season Seed Rate Chart

FAST	Recommended Seed Rate (lb/acre)		Cool Season Seed Box Meter Opening (inches)														
			1/8"	1/4"	3/8"	1/2"	5/8"	3/4"	7/8"	1"	1-1/8"	1-1/4"	1-3/8"	1-1/2"	1-5/8"	1-3/4"	1-7/8"
Seed Type	Row	Broadcast	Approximate Seed Rate (lb/acre) Based on Meter Opening														
Bahiagrass	218	435	39	88	137	186	236	285	334	383	432	481	531	580	629	678	727
Brassica Blend	8	15	65	98	132	165	199	232	266	299	333	367	400	434	467	501	534
Buffalograss	75	130	—	15	31	48	64	81	97	114	131	147	164	180	197	213	230
Cereal Grain Mixture	70	80	—	—	91	113	134	156	177	199	220	242	263	285	306	328	349
Chicory Blend	2	4	24	60	96	133	169	206	242	278	315	351	387	424	460	497	533
Clover, Red	4	6	85	125	164	204	243	283	323	362	402	441	481	521	560	600	639
Chufa	30	40	—	—	—	113	181	250	318	386	455	523	591	660	728	796	865
Corn (Round)	8	15	—	—	31	108	185	262	339	416	493	570	646	723	800	877	954
Corn (Flat)	8	15	—	—	109	167	225	283	341	399	457	514	572	630	688	746	804
Cowpeas	20	40	—	145	191	237	283	329	375	421	467	513	559	605	651	697	743
Fescue, Tall	220	435	13	30	47	64	81	98	115	133	150	167	184	201	218	235	252
Lablab Blend	20	30	—	—	93	144	195	246	297	348	399	449	500	551	602	653	704
Oats	65	95	—	—	101	135	169	204	238	272	307	341	376	410	444	479	513
Orchard Grass	10	20	8	33	58	83	108	133	158	183	208	232	257	282	307	332	357
Peas, Winter	60	85	—	73	136	199	262	325	387	450	513	576	639	702	765	828	891
Radish, Daikon	6	12	31	47	62	77	93	108	124	139	154	170	185	200	216	231	247
Rye Grass, Annual	90	320	—	37	63	88	113	138	164	189	214	239	264	290	315	340	365
Sorghum (Milo)	4	10	—	99	140	181	223	264	305	346	388	429	470	512	553	594	635
Soybeans	50	80	11	92	173	254	335	416	496	577	658	739	820	901	982	1063	1143
Sugar Beets	6	10	10	25	40	54	69	84	99	114	128	143	158	173	188	202	217
Sunflower Blend	2	10	—	—	—	69	94	118	143	168	192	217	242	266	291	315	340
Triticale	45	100	—	85	129	172	216	260	303	347	390	434	478	521	565	608	652
Wheat, Winter	75	75	—	72	124	176	228	280	332	384	436	488	540	592	644	696	748
Vetch, Hairy	30	40	—	84	140	196	252	308	364	420	476	531	587	643	699	755	811

Overseeding should be done at 50% of the recommended seed rate.

Use seed cup blockoff plates for row spacings at multiples of 7.5". This will reduce your seed rates by the percent of cups blocked.

1037382

Cool Season Conversion Chart	
Chain Drive	Multiply By
Standard	1
40 Tooth Sprocket	0.75
Slow Kit	0.60
Super Slow Kit	0.36

Legume Seed Rate Chart

Precision Super Seeder Standard Chain Drive			Legume Seed Box Meter Opening (inches)									
Seed Type	Recommended Seed Rate (lb/acre)		1/8"	1/4"	3/8"	1/2"	5/8"	3/4"	7/8"	1"	1-1/8"	1-1/4"
	Row	Broadcast	Approximate Seed Rate (lb/acre) Based on Meter Opening									
Alfalfa	15	20	8	17	27	36	46	56	65	75	85	94
Bermudagrass	44	87	5	14	23	32	41	51	60	69	78	87
Birdsfoot Trefoil	5	10	7	21	35	50	64	78	92	107	121	135
Black-eyed Susan	1	2	0	6	12	18	25	31	38	44	50	57
Bluegrass, Kentucky	45	135	—	5	11	18	24	30	36	42	48	54
Brassicas	4	8	5	13	22	30	39	48	56	65	73	82
Cereal Grain Mixture	70	80	—	—	7	20	32	45	58	70	83	96
Chicory	3	5	9	19	29	39	49	60	70	80	90	100
Clover, Red	8	15	10	23	36	49	62	75	88	102	115	128
Fescue, Tall	220	435	—	2	8	14	21	27	33	39	45	51
Flaxseed	30	45	2	15	28	41	54	67	80	93	106	119
Kale, Siberian	7	12	7	18	30	42	53	65	77	88	100	112
Lespedeza	15	20	3	11	19	27	35	43	51	59	68	76
Millet, Brown Top	10	20	6	15	24	33	41	50	59	68	77	86
Radish, Daikon	6	12	5	16	27	39	50	62	73	84	96	107
Rapeseed	2	4	—	9	16	22	28	35	41	47	53	60
Ryegrass, Annual	90	320	—	8	13	18	23	27	32	37	42	47
Sorghum (Milo)	4	10	—	28	43	58	73	88	103	118	133	148
Sugar Beets	6	10	4	14	24	35	45	56	66	77	87	97
Switchgrass	6	12	8	20	32	43	55	67	79	91	102	114
Timothy	10	15	6	16	25	35	44	54	63	73	82	92
Vetch, Hairy	30	40	—	21	35	49	64	78	92	106	121	135

Overseeding should be done at 50% of the recommended seed rate.

1037383

Legume Conversion Chart	
Chain Drive	Multiply By
Standard	1
40 Tooth Sprocket	0.75
Slow Kit	0.40
Super Slow Kit	0.25

Native Seed Rate Chart

Seed Type	Precision Super Seeder Standard Chain Drive		Native, Warm-Season Seedbox		
	Recommended Seed Rate (lb/acre)		Slow	Medium	High
	Drill	Broadcast			
Bluestem, Big	6	10	6	35	92
Bluestem, Little	7	12	6	23	46
Bromegrass	15	20	23	58	161
Canada Wildrye	10	10	29	81	230
Indiangrass	7	10	23	63	196

1037384

Native Conversion Chart	
Chain Drive - Left Side	Multiply By
Standard	1
40 Tooth Sprocket	0.75
Slow Kit	0.40
Super Slow Kit	0.14

(for chain drive on left side as standing behind seeder)

NOTICE: These charts should only be used as guides. For more accurate rates, refer to the calibration section on pages 24 and 25.

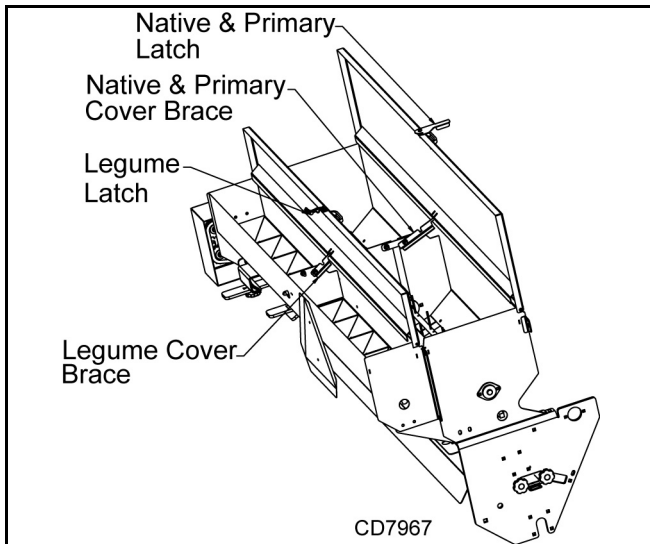

Figure 20. Seed Box Cover and Brace

Seed Rate Adjustment

Tractor speed and seed flow settings are critical for proper seed population. Use the calibration tray to adjust the seed cups for the desired seeding rate. Tractor speed (normally 2-5 mph) should be established so that uniform seed incorporation occurs with the action of the rollers. A standard sprocket (15/30 tooth) and reduced speed sprocket (15/40 tooth) are available for a wide range of seeding rates. See Figure 27.

Slow down kits are available to reduce seeding rates even further if required. P/N 1036395, PSS slow chain drive accessory, provides chains and sprockets that will reduce seeding rates by approximately 50% for the native, primary, and legume seed boxes. P/N 1036396, PSS Super slow chain drive accessory, provides chains and sprockets that will reduce seeding rates by approximately 75% of the standard drive for all three seed boxes.

Seed rates in the native seed box may be increased by removing the gaskets and retainers. Removing the gasket kit will speed up seeding rates by approximately 30%.

Seed Rate

Adjust the flow control lever (Figure 21 and Figure 24) as needed for the seed being used and the population desired. To adjust, loosen the plastic knob, move to desired position and re-tighten the knob.

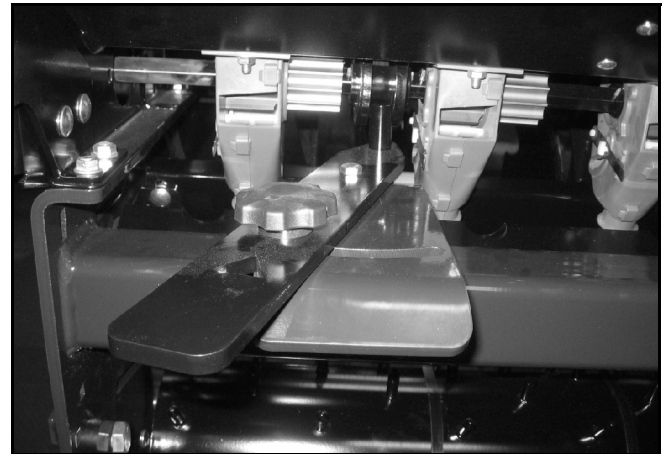

Figure 21. Primary Seed Rate Adjustment Lever

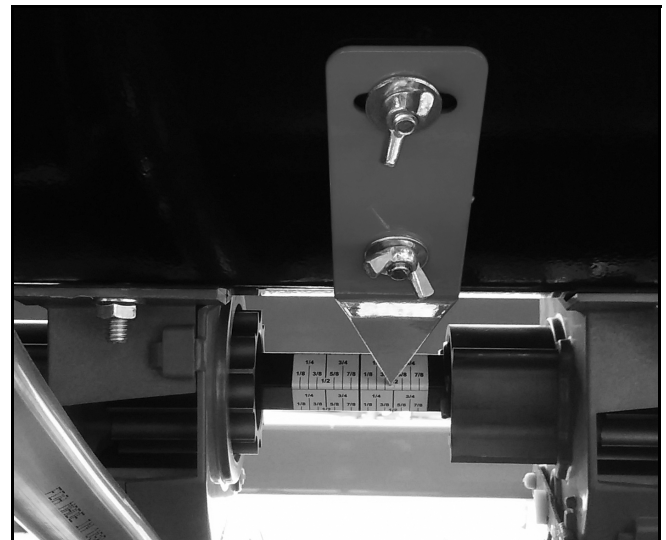

Figure 22. Pointer, Primary Box

Before seeding an area, adjust the top link so that it is in the middle of the slot with the seeder on the ground.

NOTICE: It is normal for the disc version to pitch forward at maximum front tool angle.

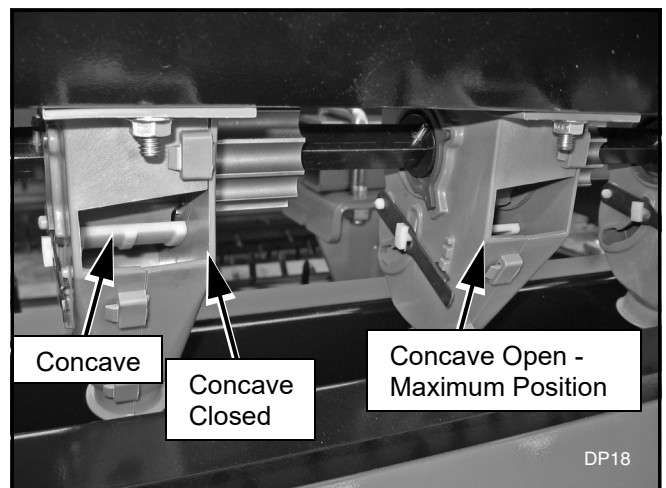

Figure 23. Primary Seed Cup Concave Adjustment

Primary Seed Cup Concave Lever Adjustment

The Primary seed cup comes equipped with an adjustable concave to handle a wide variety of seed sizes. For small seeds, including grass seeds, the concave should be at the highest position. This position will prevent the loss of seed flowing through the seed cup. For larger seeds, including soybeans, the concave should be moved to a lower position. For minimum seed rates, the concave should only be opened to the size of the seed. This will prevent cracking of large seeds by the seed cup. Opening further will increase seed rates. See Figure 23.

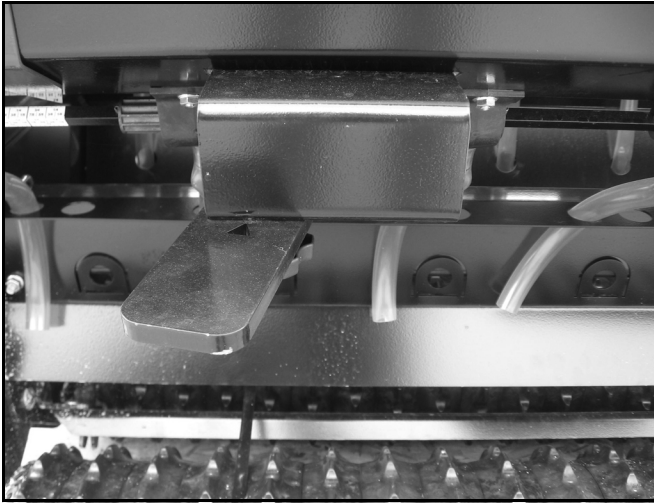

Figure 24. Legume Seed Rate Adjustment Lever



Figure 25. Pointer, Legume Box

Legume Seed Cup

The Legume seed box is equipped with PVC tubes to place the legume seed in the transition tray for the primary seed box, ahead of the front roller. The PVC tubes can be cut and the tubes repositioned in the Legume transition tray for seed to be dropped ahead of the cultipacker.

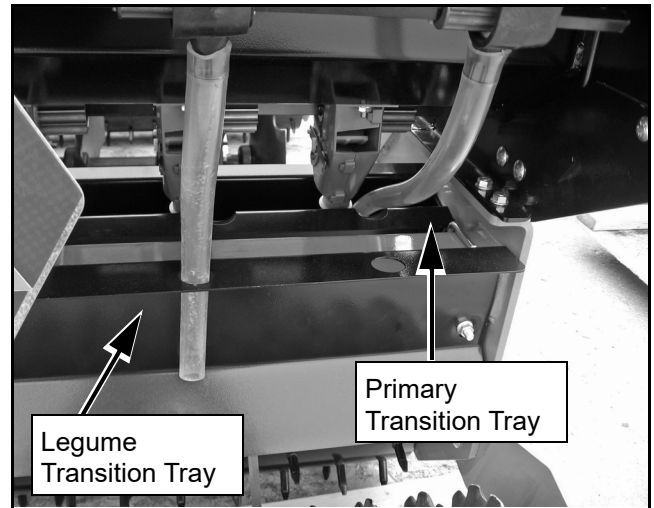

Figure 26. Legume PVC Tubes

Operating Tips

IMPORTANT

■ Before closing down the cup (reducing rates), the operator should make certain that the cups are not full of seed. If cups are full of seed (especially small, round, hard seed), it may be necessary to cover the meter holes and run seeder a short distance to reduce level of seeds in meter. Failure to do so could result in damage to seed cup.

1. Do not allow dirt to build up on the roller sprockets. Clean sprockets and chain as needed. Excessive buildup of material can cause damage to the roller and idler shafts.
2. Always run the drive chain with some slack in the chain. An extremely tight chain can damage the roller shaft, the roller bearings, and the idler shaft and bearing.

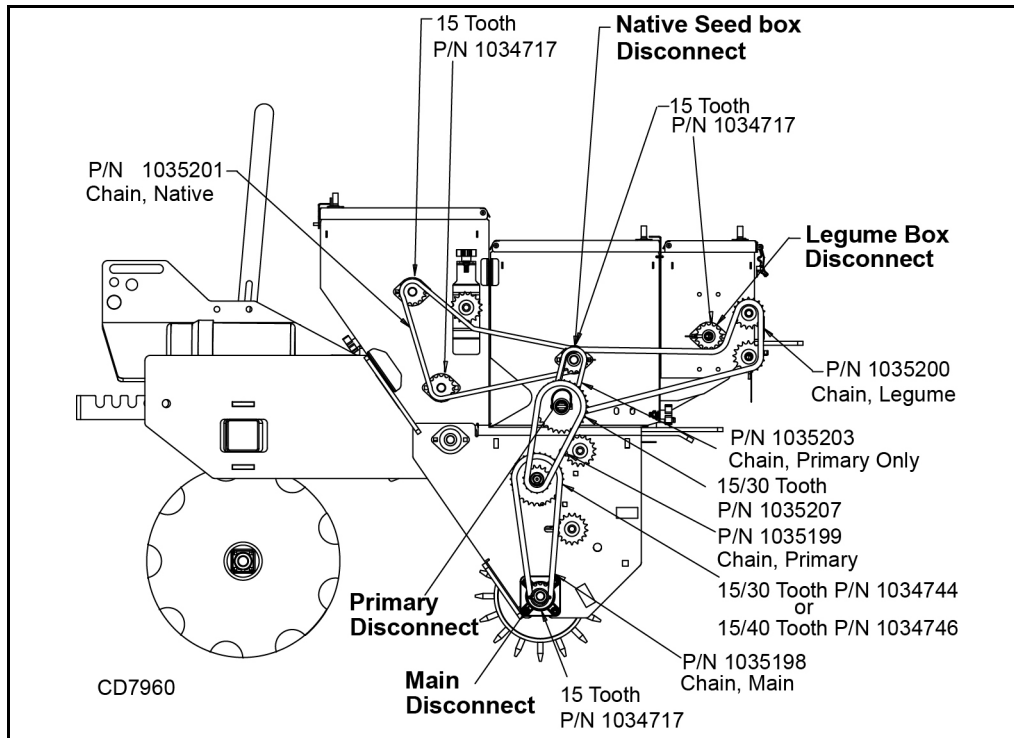

Figure 27. Standard Drive Chains and Sprockets, Left Side

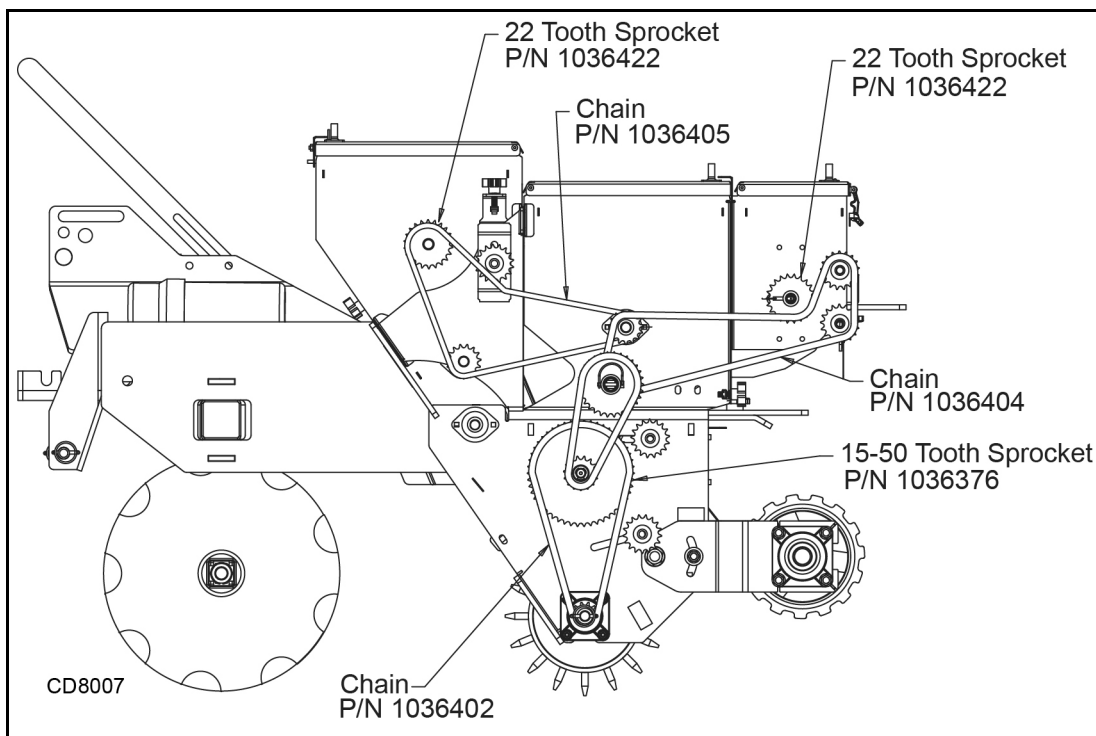

Figure 28. Slow Drive Chains and Sprockets, P/N 1036395

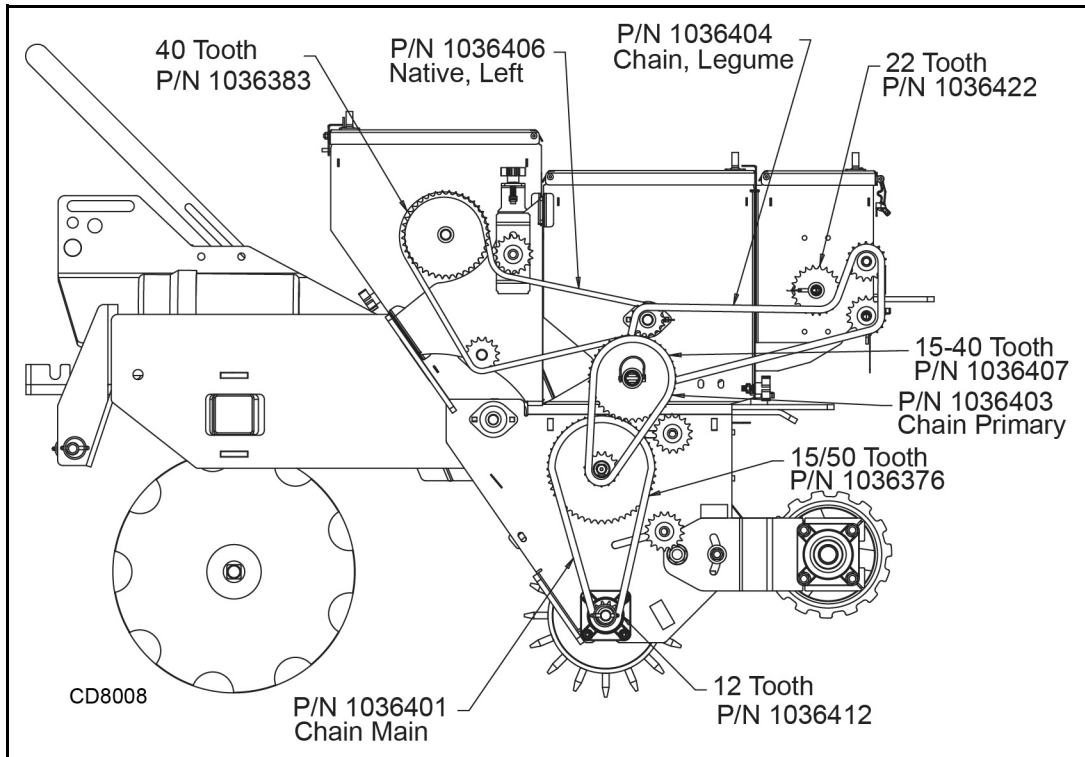

Figure 29. Super Slow Drive Chains and Sprockets, P/N 1036396

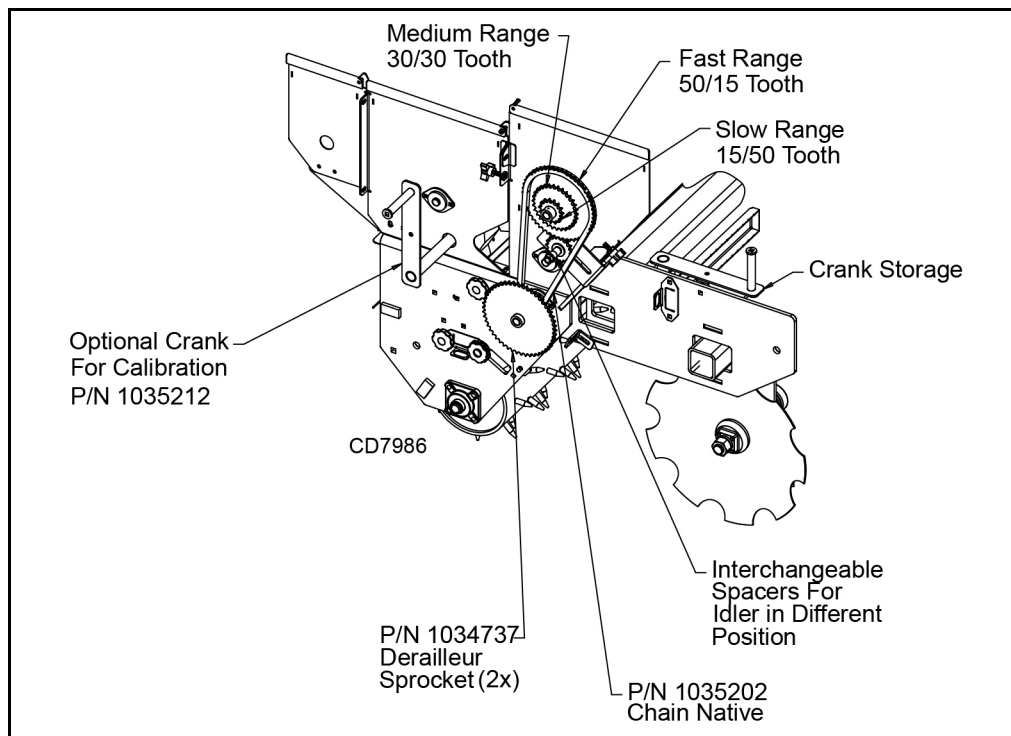

Figure 30. Standard, Native Drive Chains and Sprockets, Right Side

Cultipacker

The optional cultipacker can be used to firm the seed bed for small seeds and increase seed to soil contact. The cultipacker is equipped to operate through an inclusive angle of 37°. The cast iron cultipacker weight provides the down pressure needed for an optimized seedbed. When raising the seeder, the cultipacker will swing until it reaches its lower stop. When raising the seeder, use a slow and steady motion to reduce the impact loading of the cultipacker on the frame stop. A slot and 1/2" hardware are provided to secure the cultipacker in a fixed position. To achieve a raised position, move the cultipacker into a ditch or trailer ramp to assist in lifting. Stop the engine of the power unit and then tighten the cultipacker retainer to keep the cultipacker "raised". See Figure 31.

Calibration Tray

The Precision Super Seeder comes equipped with a calibration tray to assist in adjusting the seed cups for the desired seeding rate. The calibration tray can be used with the seeder in the stationary position or as it is pulled over a short distance of the seedbed. See Figure 31.

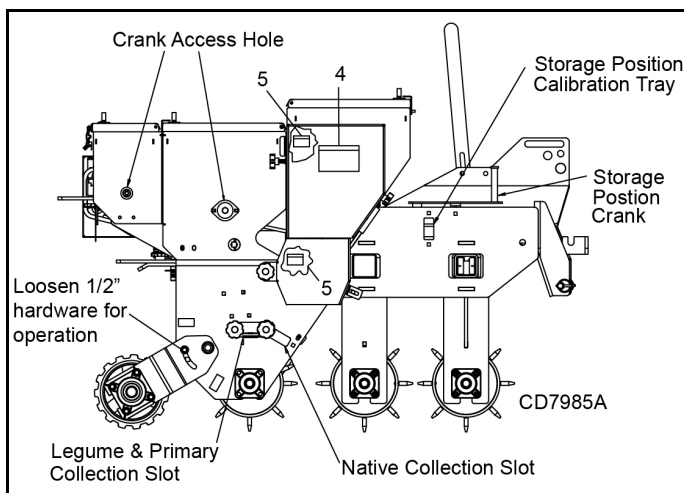

Figure 31. Calibration Tray

Stationary Calibration Procedure - Legume and Primary Seed Boxes

Equipment

1. One or two pounds of sample seed.
2. Calibration tray.
3. One scale capable of measuring ounces or hundredths of a pound.

Procedure

1. Position tractor and seeder on a level surface.
2. Adjust seed meter to closed position if applicable.
3. Stop engine and set parking brake.
4. Disconnect seed box from seeder chain drive by removing pin from seed box driven sprocket (Primary or Legume). For the native seed box, leave chain drives connected between primary seed cup shaft and picker wheels. Disconnect the ground drive and legume seed box. Drive picker wheels with primary seed cup shaft.
5. Place seed over two seed meters closest to right end of seeder.
6. Remove calibration tray (34 cu. in. capacity) from storage location. Install tray in designated collection slot and tighten against frame with two plastic nuts.
7. Open seed cups to desired position (refer to chart for estimate) and lock into place. (Primary & Legume Only)
8. Use crank or a 12-pt socket and turn primary seed cup shaft clockwise or legume seed cup shaft counter-clockwise. See stationary calibration chart for number of shaft turns. (12-pt -3/4" or 19 mm socket fits over Primary seed cup shaft. 12-pt 12 mm socket fits over Legume seed cup shaft)
9. Carefully remove calibration tray to retrieve collected seed. Weigh seed and use formula to determine seed rate. See page 21.
10. If seed rate is not correct, adjust seed cup openings and repeat steps 7 through 9.
11. Return calibration tray and crank to storage positions when finished.

Mobile Calibration Procedure - All Seed Boxes

Equipment

1. One or two pounds of sample seed.
2. Calibration tray.
3. One scale capable of measuring ounces or hundredths of a pound.

Procedure

1. Position tractor and seeder on a level surface.
2. Adjust seed meter to closed position if applicable.
3. Place seed over two seed meters closest to right end of seeder.
4. Make sure the seed box being calibrated is connected to chain drive. Disconnect other seed boxes by removing pin from seed box driven sprocket.

5. Remove calibration tray (34 cu. in. capacity) from storage location. Install tray in designated collection slot and tighten against frame with two plastic nuts (check that calibration tray does not come into contact with ground roller).
6. Open seed cups to desired position (refer to chart for estimate) and lock into place. (Primary and Legume only)
7. Lower seeder to the ground and travel 100 feet.
8. Turn off engine and set parking brake.
9. Carefully remove calibration tray to retrieve collected seed. Weigh seed and use formula to determine seed rate.
10. If seed rate is not correct, adjust seed cup openings and repeat steps 6 through 9.
11. Return calibration tray to storage position when finished.

CALIBRATION FORMULA

Stationary Calibration Chart

No. of Turns to simulate traveling 100 feet with 2 seed meters

	1 st Reduction (Sprocket Teeth)	2 nd Reduction (Sprocket Teeth)	Primary Seed Shaft Turns	Native (Primary Shaft Turns)	Legume Seed Shaft Turns
Standard Seed Drive	15-30	15-30	11.1	11.1	11.1
Optional Seed Drive	15-40	15-30	8.3	8.3	8.3
Slow Seed Drive	15-50	15-30	6.6	6.6	4.5
Super Slow Seed Drive	12-50	15-40	4	4	2.7

NOTICE: To calibrate the native seed box, leave the chain drive connected between the primary seed cup shaft and the native seed drive. Disconnect the ground drive and legume seed box. Turn the primary seed cup shaft per the chart above, to collect seed in the native calibration slot.

Multiply calibration weight by 373.4

Example: .15 lbs collected with 15/30 tooth standard sprocket and 11.1 turns of seed cup

.15 lbs x 373.4 = 56 lbs/acre

Metric Example: 68 grams collected with 15/30 tooth standard sprocket and 11.1 turns of seed cup

68 grams x 373.4 = 25.4 kg/acre or 62.8 kg/hectare

NOTICE: Overlapping and rough terrain/fast travel speeds will impact seed metering accuracy. The amount determined at calibration will increase by 10 to 30% in actual seeding depending on these factors.

Conversion for Grams to Pounds:

453.6 grams / 1 pound **OR**

.0022 pounds / 1 gram

Conversion for Ounces to Pounds:

16 ounces / 1 pound **OR**

.0625 pounds / 1 ounce

TRANSPORTATION

CAUTION

- Always raise unit and install transport lock before transporting. Leak down or failure of mechanical/electrical or hydraulic system can cause equipment to drop.
- Always attach safety chain to tractor drawbar when transporting unit.

Transport Lock Up

IMPORTANT

- Always transport with the cylinder in the full extended, locked position.

1. Fully extend cylinder.
2. Remove hair pin cotter and bent pin from unlocked position.
3. Locate transport lock over cylinder rod.
4. Place bent pin and hair pin cotter in locked position. (See Figure 32.)

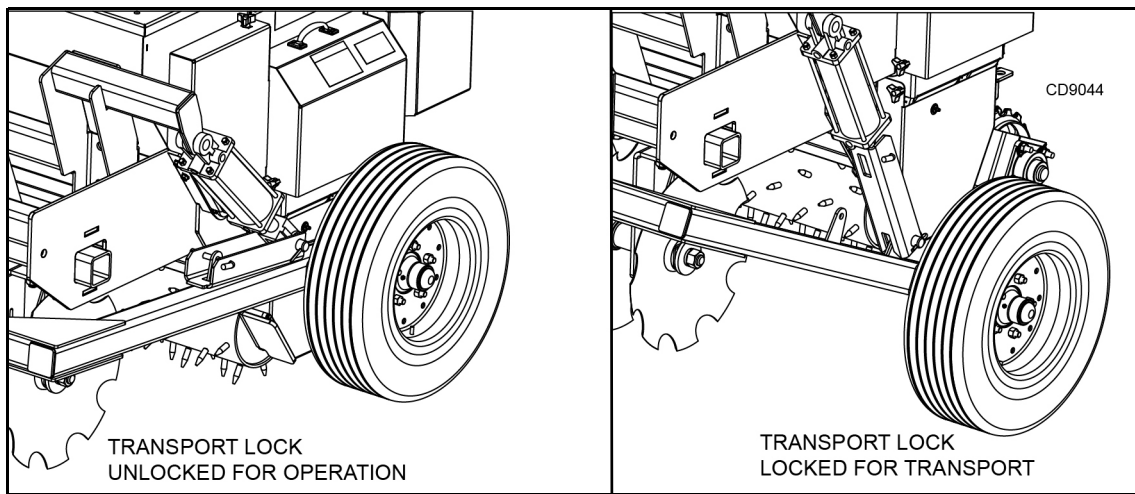

Figure 32. Transport Lock Positions

PRE-OPERATION CHECK LIST

(OWNER'S RESPONSIBILITY)

- ___ Review and follow all safety rules and safety decal instructions on page 5 through page 9.
- ___ Check that equipment is properly and securely attached to tractor.
- ___ Check that all safety decals are installed and in good condition. Replace if damaged.
- ___ Do not allow riders.
- ___ Check that all hardware is properly installed and secured.
- ___ Check that shields and guards are properly installed and in good condition. Replace if damaged.
- ___ Check all lubrication points and grease as instructed in Lubrication Information, Figure 33.
- ___ Make sure tractor ROPS or ROPS cab and seat belt are in good condition. Keep seat belt securely fastened during operation.

OWNER SERVICE

The information in this section is written for operators who possess basic mechanical skills. If you need help, your dealer has trained service technicians available. For your protection, read and follow the safety information in this manual.

WARNING

■ **NEVER GO UNDERNEATH EQUIPMENT.** Never place any part of the body underneath equipment or between moveable parts even when the engine has been turned off. Hydraulic system leak-down, hydraulic system failures, mechanical failures, or movement of control levers can cause equipment to drop or rotate unexpectedly and cause severe injury or death.

- Service work does not require going underneath implement.
- Read Operator's Manual for service instructions or have service performed by a qualified dealer.

■ **Keep all persons away from operator control area while performing adjustments, service, or maintenance.**

■ **Before dismounting power unit or performing any service or maintenance, follow these steps: disengage power to equipment, lower the 3-point hitch and all raised components to the ground, operate valve levers to release any hydraulic pressure, set parking brake, stop engine, remove key, and unfasten seat belt.**

CAUTION

■ **Always wear relatively tight and belted clothing to avoid getting caught in moving parts. Wear sturdy, rough-soled work shoes and protective equipment for eyes, hair, hands, hearing, and head; and respirator or filter mask where appropriate.**

TIGHTENING CULTIPACKER WHEEL ASSEMBLY

1. Place cultipacker on level, dry surface, with the cultipacker cast iron wheels on the ground.
2. Loosen 1/2" flange nuts and bolts on cast iron end clamps.
3. Use a pry bar to tighten the wheels together.
4. Re-tighten the 1/2" flange nuts and bolts on the clamps.

REMOVING CULTIPACKER SHAFT FROM FRAME

1. Place cultipacker on level, dry surface, with the cultipacker cast iron wheels on the ground.
2. Loosen bearing set screws with 5/32" Allen wrench. Place a punch in the eccentric locking collar punch hole and tap the collar loose in the opposite direction of shaft operation.
3. Remove 1/2" flange lock nuts and bolts from bearing assembly. Repair or replace cultipacker assembly as needed or refer to tightening cultipacker wheel assembly if applicable.
4. Match holes in cultipacker frame with holes in bearings and assemble with 1/2" bolts and flange lock nuts.
5. Lock eccentric bearing collars to cultipacker shaft by driving the collar in the direction of forward travel by placing a punch in the hole in the collar and driving it with a hammer. Secure collar to shaft with set screw.

LUBRICATION INFORMATION

Bearings with grease fittings	QTY	Sprockets with grease fittings	QTY
Front Roller	4	Native Box	2
Drive Roller	2	Primary Box	2
Disc	0	Legume Box	1
Cultipacker	2	Seeder Frame	2
Seed Boxes	0		
Wheel Spindle	2		

1. Lubricate all bearing housings every 8 hours. Bearing housings are located on each end of rollers as indicated by grease fitting. See Figure 33.
2. Lubricate chains and sprockets (with grease zerks) every 50 hours or season whichever is shorter. The seed boxes are sealed with 3M 760 sealant. If a leak occurs in the seed box apply a 3/16" bead of 3M 760 sealant to eliminate any leaks. The tack free time is 30 minutes with full cure in 24 hours.
3. Clean fittings prior to lubrication. Do not let excessive grease build up around lubrication points.

NOTE: One pump of a good multi-purpose grease should be sufficient in most cases. Harsh or dry conditions may require more frequent lubrication. If tow kit is installed, lubrication service is best performed with seeder fully raised and transport locks in place.

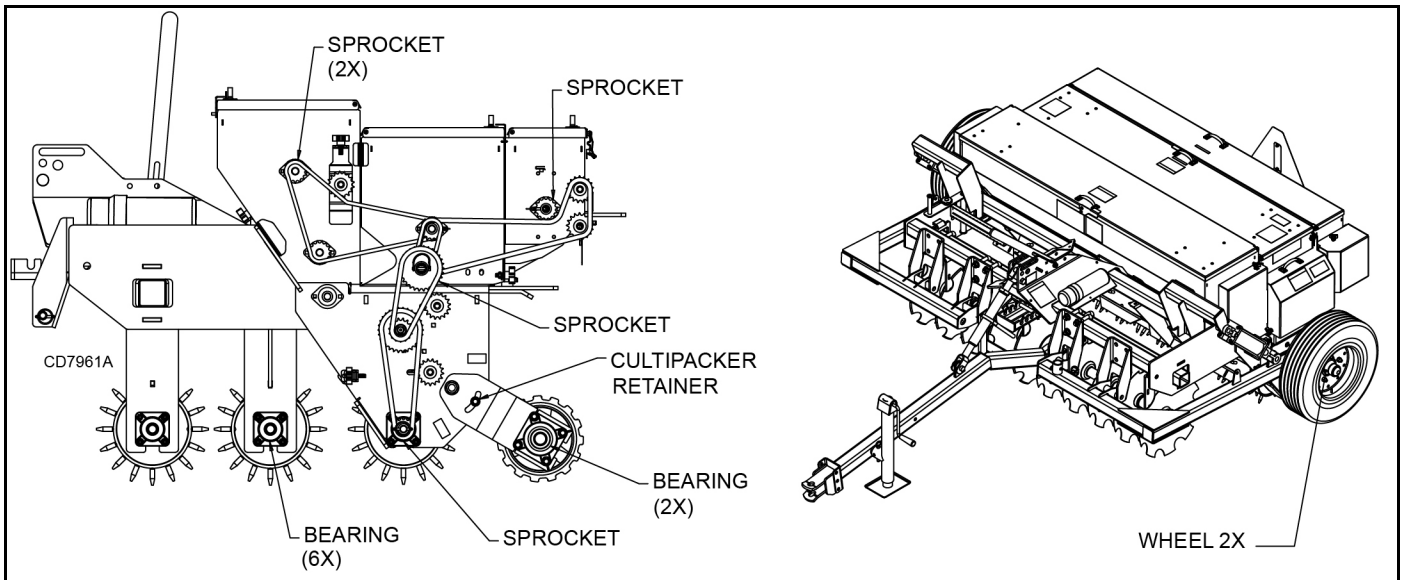

Figure 33. Lubrication Points

SERVICING TIRES SAFELY

⚠ WARNING



■ Explosive separation of tire and rim parts can cause serious injury or death. Release all air pressure before loosening bolts.

Do not attempt to mount a tire unless you have the proper equipment and experience to perform the job.

Always maintain the correct tire pressure. Do not inflate tires above the recommended pressure. Never weld or heat a wheel and tire assembly. The heat can cause an increase in air pressure and result in a tire explosion. Welding can structurally weaken or deform the wheel.

When inflating tires, use a clip-on chuck and an extension hose long enough to allow you to stand to the side, not in front of or over the tire assembly. Use a safety cage if available.

Check wheels for low pressure, cuts, bubbles, damaged rims, or missing lug bolts and nuts.

Never remove split rim assembly hardware (A) with the tire inflated.



Figure 34. Split Rim Tire Servicing

CLEANING

After Each Use

- Remove large debris such as clumps of dirt, grass, crop residue, etc. from machine.
- Inspect machine and replace worn or damaged parts.
- Replace any safety decals that are missing or not readable.

Periodically or Before Extended Storage

- Clean large debris such as clumps of dirt, grass, crop residue, etc. from machine.
- Remove the remainder using a low-pressure water spray.
 1. Be careful when spraying near scratched or torn safety decals or near edges of decals as water spray can peel decal off surface.

2. Be careful when spraying near chipped or scratched paint as water spray can lift paint.

3. If a pressure washer is used, follow the advice of the pressure washer manufacturer.

- Inspect machine and replace worn or damaged parts.
- Sand down scratches and the edges of areas of missing paint and coat with Woods spray paint of matching color (purchase from your Woods dealer).
- Replace any safety decals that are missing or not readable (supplied free by your Woods dealer). See Safety & Instructional Decals section for location drawing.



ASSEMBLY

DEALER SET-UP INSTRUCTIONS

Assembly of this equipment is the responsibility of the Woods dealer. It should be delivered to the owner completely assembled, lubricated, and adjusted for normal operating conditions.

In most cases the Precision Super Seeder is shipped completely assembled from the factory. The native and legume seed boxes, front disc roller, front studded roller and cultipacker are options that can be added to the Precision Super Seeder at a later time if desired.

OPTIONAL ACCESSORIES

Front Spike Roller (For illustration, see page 43)

1. Place seeder on level surface with jack stands on frame 3 x 3 tubes.
2. Stop engine and set parking brake.
3. Place hoist strap over 3 x 3 disc gang.
4. Remove 3/4" U-bolts and nuts connecting 3 x 3 tube to disc slide.
5. Carefully remove disc gangs from underneath seeder.



■ Notched disc blades are sharp. Wear gloves and tight-fitting clothing.

6. Remove bent pin and hair pin clip from disc slide.
7. Remove 3/4" bolt, nut, washer and sleeve from disc slide.
8. Remove disc slide and replace with roller slide, sleeves, and 3/4" hardware.
9. Carefully position front rollers into frame receiving holes and attach to front roller slide with 3/4" hardware and sleeves.
10. Install bent pin into roller slide and lock with hair pin clip.

Front Disc (For illustration, see page 48)

1. Place seeder on level surface.
2. Stop engine and set parking brake.
3. Remove 3/4" hardware connecting 3 x 3 tubes to roller slide.
4. Using hoist strap, carefully remove rollers from underneath seeder.
5. Remove bent pin and hair pin clip from roller slide.
6. Remove roller slide and sleeves from frame rails.

7. Install disc slide on frame rails using 3/4" hardware, 3/8" thick washer and sleeves.
8. Install bent pin and hair pin clip on disc slide in fourth hole from rear.
9. Install disc gang in frame receiver hole and on disc slide with 3/4" hardware.

Native Seed Box (For illustration, see page 46)

1. Place seeder on level surface.
2. Stop engine and set parking brake.
3. Remove seed box braces from front of primary seed box.
4. Remove shields from native seed box.
5. Open shield from primary box.
6. Install native transition tray using 3/8" hardware.
7. Move front transition tray of primary seed box to bottom of native transition tray and attach with 3/8" hardware. Also, attach front transition tray to frame with 3/8" hardware.
8. Place picker wheel shaft in frame of seeder with teeth fingerpoints rotating forward and downward.
9. Install 3/4" flanged bearings on either side of picker wheel shaft and connect to frame using 5/16" hardware.
10. Attach native seed box to frame and primary seed box using 3/8" hardware (the primary seed box mounts may need to be loosened).
11. Attach middle bearing of picker wheel to native seed box with 3/8" hardware.
12. Adjust picker wheel positions so they are centered in seed box slots. Tighten picker wheels and bearings to shaft.
13. Install 15 tooth sprocket on primary box agitator shaft. Sprocket goes inside primary bearing mount and 15 tooth sprocket that is connected to the frame chain drive sprocket.
14. Install 15 tooth sprocket on left side of picker wheel shaft and align sprocket and shaft with sprocket on seed box.
15. Install left hand idler sprocket using 1/2" hardware.
16. Install left hand drive chain on native seed box agitator shaft, power transmission shaft and primary box agitator shaft.
17. Install right hand idler sprocket using 1/2" hardware.
18. Install right hand drive chain on power transmission shaft and picker wheel shaft.

19. Install left hand shield with 1/4" hardware to primary box shield.
20. Install right hand shields.

Legume Seed Box (For Illustration, see page 44)

1. Place seeder on level surface.
2. Stop engine and set parking brake.
3. Open primary seed box shield.
4. Remove seed box braces from rear of primary seed box.
5. Remove SMV sign from primary seed box saving 1/4" hardware.
6. Install legume seed box on primary seed box frame.
7. Install 3/16" thick legume seed box braces on frame, primary box and legume box using 5/16" and 3/8" hardware.
8. Remove short agitator chain from primary seed box.
9. Install legume drive chain around primary seed cup shaft, primary seed box agitator, underneath legume seed cup shaft and around legume idler sprockets.
10. Install SMV sign on legume box with 1/4" hardware.
11. Install legume shield to primary box shield with 1/4" hardware.
12. Install legume transition tray on rear 3 x 3 tube with U-bolts.
13. Install seed cup PVC tubes on seed cups and insert into legume transition tray.

Cultipacker (For Illustration, see page 50)

1. Place seeder on level surface.
2. Stop engine and set parking brake.
3. Match cultipacker mounts with holes in frame and install 3/4" x 2 bolt, 3/4" washer and 3/4" flanged lock nuts. Place washer between frame and cultipacker mounts.
4. Install 1/2" bolts and flanged lock nuts in frame and slot of cultipacker mount.

Tow Kit (for illustration, see page 61 and page 62)

1. Place seeder on level surface.
2. Loosely install right and left cylinder hangers at ends of middle frame tube using 3/4" u-bolts and flange lock nuts.
3. Loosely install second set of hitch brackets on the front frame tube, outside the factory hitch brackets, using 3/4" u-bolts and flange lock nuts.

4. Loosen 3/4" u-bolts and flanged nuts from factory-installed hitch brackets.
5. Position tongue between factory 3-point hitch brackets. Slide factory hitch brackets together until tongue is centered on frame and fit tightly between brackets. Slide lower hitch pins through tongue and reinstall klik pins.
6. Position right and left wheel arm weldments at the front of the seeder frame. The left wheel arm can be identified by the jack storage tube on the top surface.
7. Connect wheel arms to lower hitch brackets with the hitch pins. Wheel arm ears should be centered inside the channel of each hitch bracket. Retain hitch pins with klik pins.
8. Tighten inner and outer set of hitch brackets to front frame tube.
9. Install wheel hubs into sleeves at ends of wheel arms. Retain with 1/2" x 3-1/4" cap screw and flange lock nuts.
10. Install 20.5 x 6.5-10 aircraft tires to wheel hubs.
11. Remove 3/8" knob and calibration crank from seeder frame. Relocate calibration crank to right side cylinder hanger in square hole using existing carriage bolt and push on washer.
12. Install right and left cylinder assemblies between appropriate cylinder hangers and wheel arms with cylinder barrel to the top. Use standard cylinder pin to connect cylinder to frame hanger. Use 1.00" x 4.08" pin for connection to wheel arm; orient rod end as shown in Figure 33. Retain with cotter pins. Safety decals should be readable from alongside seeder, facing away from wheel arms.



Figure 35. Cylinder Rod End Installed

13. Install right and left cylinder transport locks over cylinder rod-end clevis connection to wheel arm. The channel should be facing up and safety decal

oriented properly for readability from alongside seeder. Install bent retainer pin with hairpin clip.

14. Install parking jack on mounting tube on tongue and pin in place.
15. Install clevis drawbar hitch and safety chain using 5/8" x 6-1/2" cap screws and lock nuts. Install 5/8" heavy flat washer over safety chain retainer loop.
16. Install hose holder on tongue using 5/8" x 4-1/2" cap screw and lock nut.
17. Remove CAT 1 quick hitch sleeve from seeder a-frame, 3/4" x 4" cap screw and lock nut. Install ratchet jack in same a-frame hole using 3/4" x 4-1/2" hitch pin and sleeve. Attach ratchet jack to tongue using standard ratchet jack pin and retainer.
18. Drill two 9/32" holes into seeder frame approximately 8.5" from mast plates. Drill two 11/32" holes into mast plate at the front of seeder 6.5" from the bottom edge, if applicable (see Figure 36.)

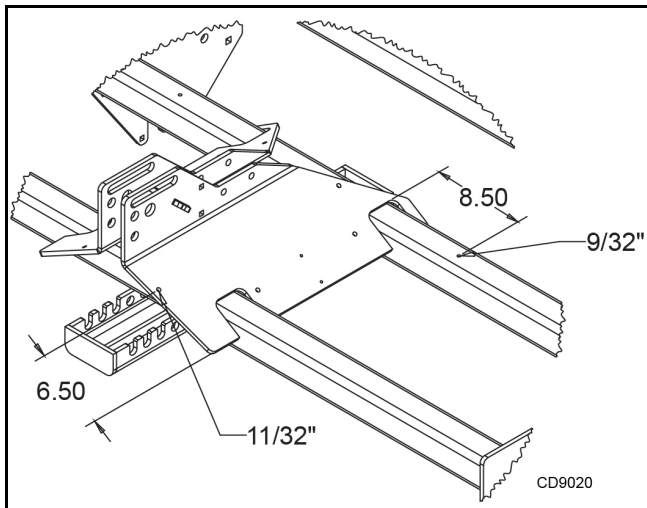

Figure 36. P-clip Hole Locations

19. Install hydraulic fittings into double-acting cylinders and run hydraulic hoses across middle frame tube and under a-frame mast plates. P-clips and butterfly clips are included to securely hold hoses to prevent rubbing on the frame edges (see Figure 35B). Use self-tap screws to secure butterfly clips to frame tube. Cylinder hoses should be tee'd together with provided union fittings. The long tractor connect hoses should be routed through the hose holder on the tongue. Install 1/2" NPT ISO couplers on ends of hoses and lay them in the hose holder.
20. Bolt SMV socket to seedbox. Remove SMV from rear seebox and bolt together stake, SMV/SIS bracket, and SMV. Insert stake into socket.

NOTICE: Clamping the long hose by the ferrule will provide additional support to the routing. See Figure 37A.



Figure 37A. Hose Routing



Figure 35B. Hose Routing

SEEDER LIGHT KIT 604387 INSTALLATION INSTRUCTIONS

1. Remove plastic plugs from Primary Seed box cover.
2. Apply RTV sealant to all holes in the seed box lid.
3. Install two LED red and amber light modules on the seed box cover with 1/4" x 1" long hex head cap screws. The amber lenses should be oriented toward the outside edge of the cover, facing rearward. Install with the hex head of the bolt on top of the module going through the seed box holes and applying 1/4" whiz nuts underneath the seed box cover. (See Figure 38).



Figure 36. Light Module

4. Route the lead wire of the module through 1/2" cushioned clamps. Attach the 1/2" cushioned clamps in the hole behind module with 1/4" x 1" long hex head cap screw and 1/4" whiz nut.
5. Connect the intermediate harnesses to the appropriate light modules. Route lead wire through second 1/2" cushioned clamp. Remove forward mounting hardware from base of cool season seed box. Reinstall with cushioned clamp on top of seed box base. (See Figure 38).
6. If the seeder has a front native seed box, route the intermediate harness through the slot of the native seed tray, up between the primary and native box, to the LED light module wires and connect the 4 pin terminals.



Figure 37. Enhancer Module

7. Install enhancer module on right-hand side mast plate with #10 self-tapping screws. Route wires through 1/2" cushioned clamps and attach clamps in front of and behind enhancer module with 1/4" x 1" hex head cap screws and 1/4" whiz nuts. (See Figure 39).
8. Connect intermediate harness to the enhancer module. Route intermediate harness along front of 3x3 tube at the rear of the mast plates. Drill two holes in the front of each frame tube. The holes should be approximately 2.00" to 3.00" from the frame sides and mast plates. Attach two 1/2" cushioned clamps to each side using #10 self-tapping screws to control wire harness. (See Figure 40).

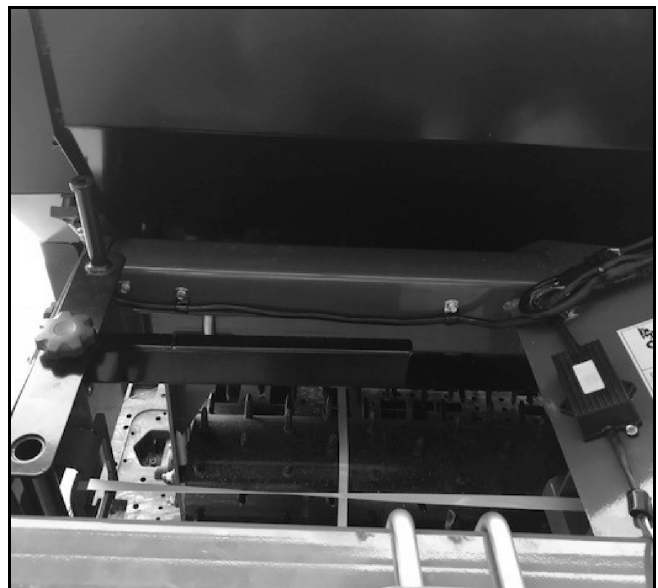

Figure 38. Intermediate Harness Routing

9. Connect four foot lead with seven pin plug to enhancer module.
10. Install seven pin plug holder to right-hand mast plate with 3/8" x 1 hex head cap screw and 3/8 flange lock nut in holes provided in mast plate. (See Figure 41).

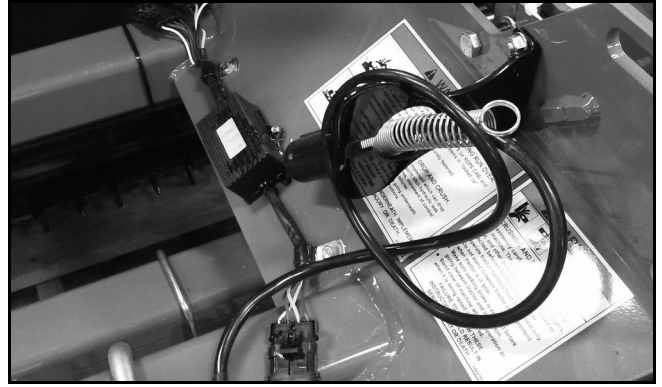

Figure 39. Seven Pin Plug Holder

DEALER CHECK LISTS

PRE-DELIVERY CHECK LIST

(DEALER'S RESPONSIBILITY)

Inspect the equipment thoroughly after assembly to ensure it is set up properly before delivering it to the customer.

The following check lists are a reminder of points to inspect. Check off each item as it is found satisfactory or after proper adjustment is made.

- ___ Check that all safety decals are installed and in good condition. Replace if damaged.
- ___ Check that shields and guards are properly installed and in good condition. Replace if damaged.
- ___ Check all bolts to be sure they are properly torqued.
- ___ Check that all cotter pins and safety pins are properly installed. Replace if damaged.
- ___ Check and grease all lubrication points as identified in lubrication information on page 29.
- ___ Loosen 1/2" bolts in cultipacker arm slots to allow cultipacker to float. See Figure 31.

DELIVERY CHECK LIST

(DEALER'S RESPONSIBILITY)

- ___ Show customer how to make adjustments and select proper ground speed.

- ___ Show customer the safe, proper procedures to be used when mounting, dismounting, and storing equipment.
- ___ Make customer aware of optional equipment available so that customer can make proper choices as required.
- ___ Instruct customer how to lubricate and explain importance of lubrication.
- ___ Point out the safety decals. Explain their meaning and the need to keep them in place and in good condition. Emphasize the increased safety hazards when instructions are not followed.
- ___ Present Operator's Manual and request that customer and all operators read it before operating equipment. Point out the manual safety rules, explain their meanings and emphasize the increased safety hazards that exist when safety rules are not followed.
- ___ Explain to customer the potential crushing hazards of going underneath raised equipment. Explain that blocking up prevents equipment dropping from hydraulic leak down, hydraulic system failures or mechanical component failures.
- ___ Point out all guards and shields. Explain their importance and the safety hazards that exist when not kept in place and in good condition.
- ___ Explain to customer that when transporting the unit on a public road to comply with all state and local lighting/marketing laws.

PRECISION SUPER SEEDER

PSS48**PSS60****PSS72****PSS84**

Main Frame and Roller Assembly38 - 39
Primary Seed Box Assembly40 - 42
Front Spike Roller Option43
Legume Seed Box Option44 - 45
Native Seed Box Option46 - 48
Front Disc Option (S/N 1285001 & Above)48
Front Disc Option (S/N 1285000 & Below)41
Cast Iron Cultipacker Option50
Nylon Cultipacker Option51
Scrapers - Spiked Roller Option52
Scrapers - Disc Spiked Drive Roller Option53
Scrapers - Cast Iron Cultipacker Option54
Scrapers - Nylon Cultipacker Option55
Row Units56
Slow Chain Drive Accessory Parts57
Super Slow Chain Drive Accessory Parts58
Platform Accessory Parts59
Light Kit Option60
Tow Kit Option61 - 62

PSS48, PSS60, PSS72 & PSS84 MAIN FRAME & ROLLER ASSEMBLY

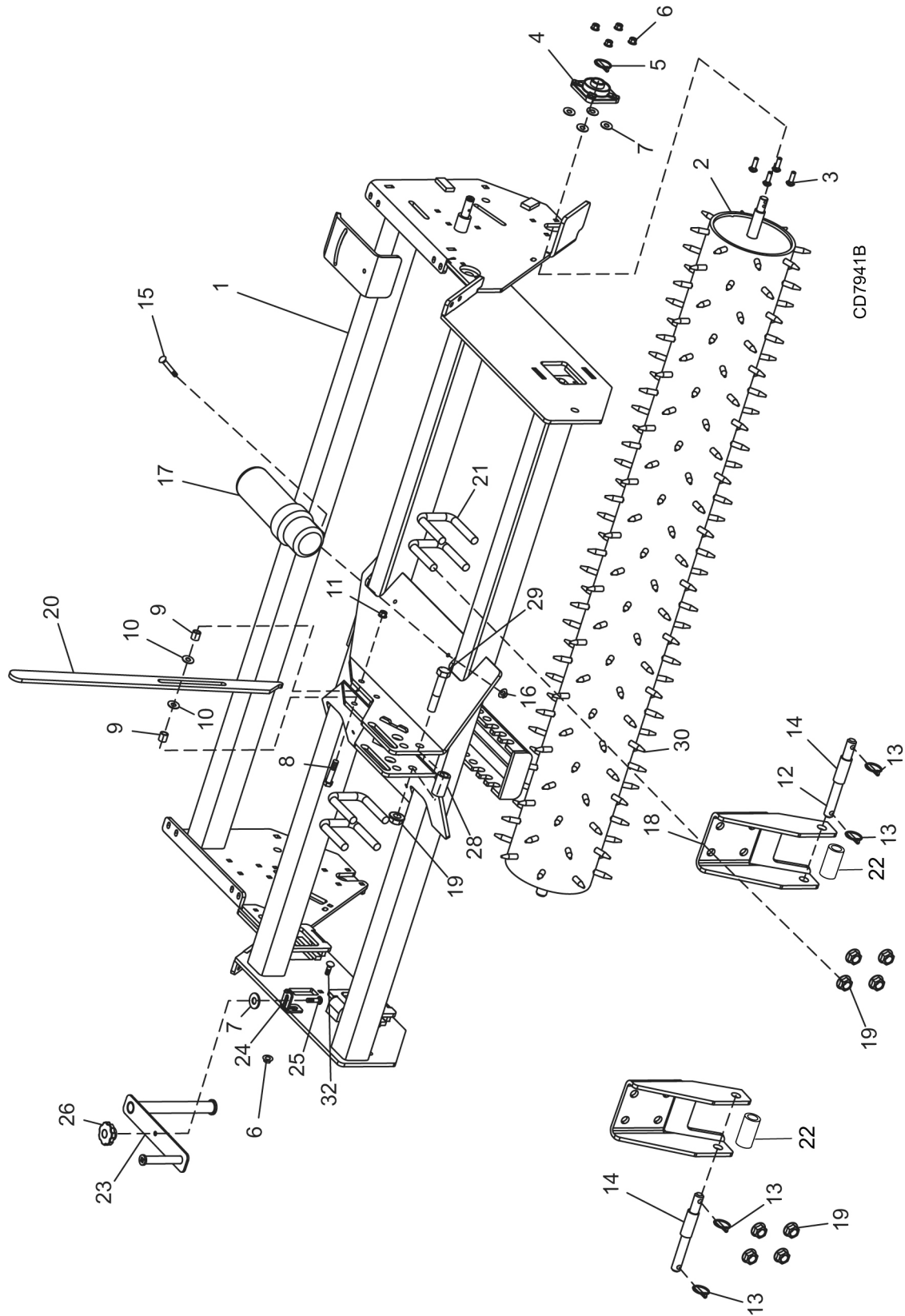

PSS48, PSS60, PSS72, PSS84 MAIN FRAME & ROLLER ASSEMBLY PARTS LIST

REF	PSS48	PSS60	PSS72	PSS84	QTY	DESCRIPTION
1	1	Frame, seeder
2	103877648RP	103877660RP	103877672RP	103877684RP	1	Spiked drive roller
3	W301117*	W301117*	W301117*	W301117*	8	3/8 NC x 1-3/4 carriage bolt ZP
4	20A920	20A920	20A920	20A920	2	1" bearing with housing
5	62043*	62043*	62043*	62043*	1	1/4 x 1-3/4 klik pin
6	14350*	14350*	14350*	14350*	8	3/8 NC flanged lock nut
7	1028375*	1028375*	1028375*	1028375*	8	3/8 push-on nut
8	1637*	1637*	1637*	1637*	1	1/2 NC x 3-1/2 cap screw GR5 ZP
9	1035651RP	1035651RP	1035651RP	1035651RP	2	Sleeve, .56 x .75 x .75
10	3598*	3598*	3598*	3598*	2	1/2 SAE flat washer
11	11900*	11900*	11900*	11900*	1	1/2 NC flanged lock nut
12	HBL233	HBL233	HBL233	HBL233	2	.875 x 6.94 headless pin
13	27542*	27542*	27542*	27542*	4	7/16 x 11/32 klik pin
14	56598	56598	56598	56598	2	Sleeve, .885 x 1.125 x 2.62
15	24409*	24409*	24409*	24409*	2	5/16 NC x 1 carriage bolt ZP
16	14139*	14139*	14139*	14139*	2	5/16 NC flanged lock nut ZP
17	1003828	1003828	1003828	1003828	1	Manual tube
18	1034699RP	1034699RP	1034669RP	1034669RP	2	Mount, hitch seeder
19	W302207*	W302207*	W302207*	W302207*	9	3/4 NC flanged lock nut
20	1035193RP	1035193RP	1035193RP	1035193RP	1	Handle
21	1034668	1034668	1034668	1034668	4	3/4 x 3.81 x 4.31 U-bolt
22	1002012	1002012	1002012	1002012	2	Sleeve, .94 x 1.44 x 2.75
23	1036370	1036370	1036370	1036370	1	Kit, crank, calibration
24	1035232RP	1035232RP	1035232RP	1035232RP	1	Mount, transition tray
25	6697*	6697*	6697*	6697*	1	3/8 NC x 1 carriage bolt GR5 ZP
26	66840	66840	66840	66840	1	3/8 NC knob, 3 prong
28	1002018	1002018	1002018	1002018	1	Sleeve, 81 x 1.25 x 2.12
29	31207	31207	31207	31207	1	3/4 NC x 4 cap screw GR5 ZP
30	1002938	1002938	1002938	1002938	1	Replacement spikes (25 piece set)
32	20973	20973	20973	20973	1	3/8 NC x 1-1/4 carriage bolt ZP

* Standard hardware, obtain locally

PSS48, PSS60, PSS72, PSS84 PRIMARY SEED BOX ASSEMBLY

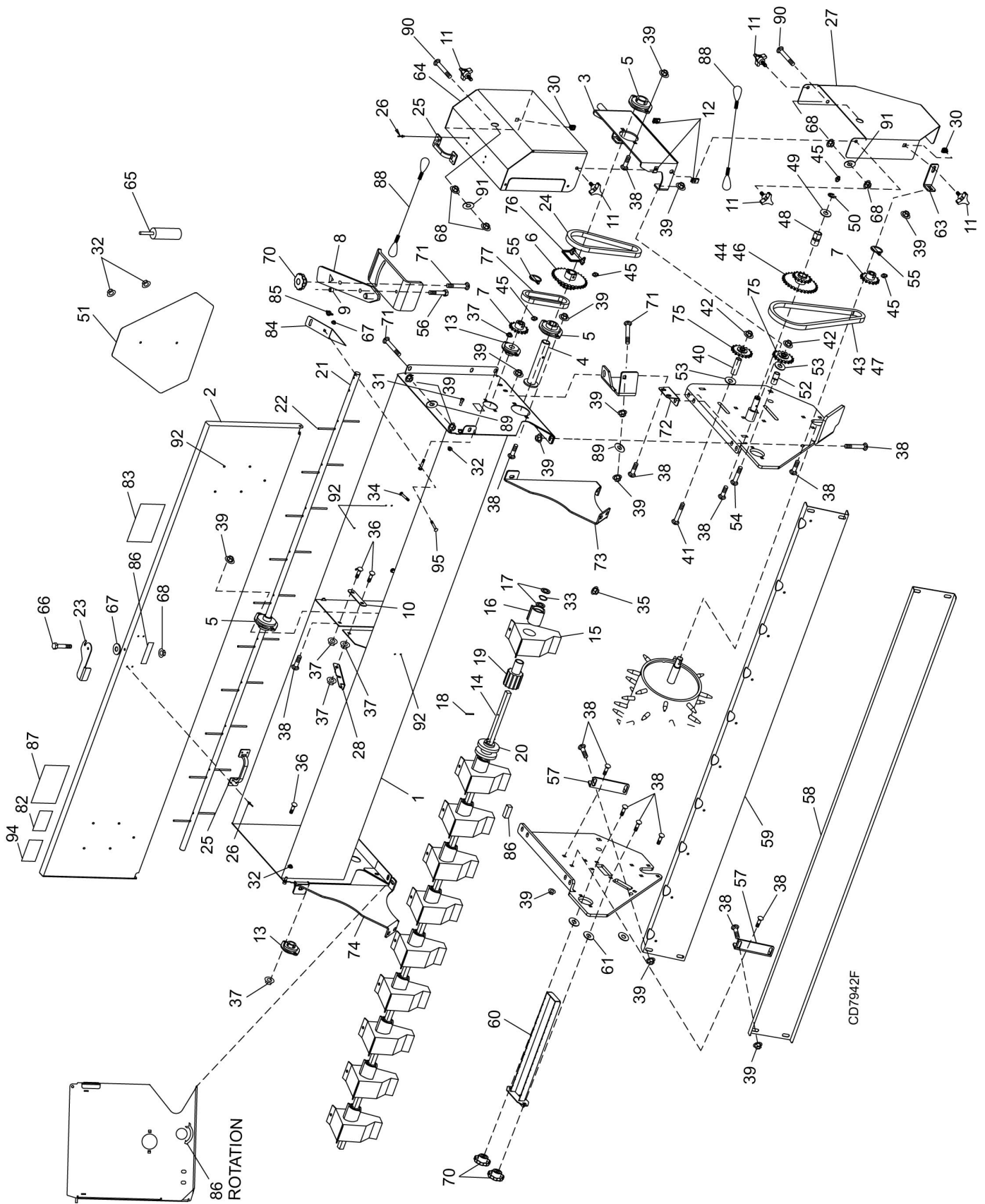

(Rev. 8/27/2021)
MAN0988 (11/5/2012)

Parts 40

PSS48, PSS60, PSS72, PSS84 PRIMARY SEED BOX PARTS LIST

REF	PSS48	PSS60	PSS72	PSS84	QTY	DESCRIPTION
1	103517948RP	103517960RP	103517972RP	103517984RP	1	Seedbox, Primary
2	103569848RP	103569860RP	103569872RP	103569884RP	1	Cover, seedbox Primary, Native
3	1035663RP	1035663RP	1035663RP	1035663RP	1	Mount, bearing Primary
4	1034739RP	1034739RP	1034739RP	1034739RP	1	Tube, transmission
5	1034694	1034694	1034694	1034694	3	1-1/8 bearing, flangette
6	1035207	1035207	1035207	1035207	1	Sprocket weldment
7	1034717	1034717	1034717	1034717	2	Sprocket
8	1035219RP	1035219RP	1035219RP	1035219RP	1	Lever, Primary
9	24516	24516	24516	24516	1	Sleeve, 3/8 x 1/2 x 27/64
10	1035197RP	1035197RP	1035197RP	1035197RP	2	Link
11	1033294	1033294	1033294	1033294	5	3/8 NC x 1.00 knob, 3 prong LG
12	1033293*	1033293*	1033293*	1033293*	3	3/8 - 16 spring nut, u-tapped
13	1034693	1034693	1034693	1034693	2	3/4 bearing, flangette
14	103518448RP	103518460RP	103518472RP	103518484RP	1	Shaft, primary seedcup
15	1034754 (7)	1034754 (8)	1034754 (10)	1034754 (12)		Seedcup, large
16	1034755 (7)	1034755 (8)	1034755 (10)	1034755 (12)		Gate, seedcup, large
17	1034712RP (14)	1034712RP (16)	1034712RP (20)	1034712RP (24)		Washer, primary seedcup
18	1035188 (16)	1035188 (18)	1035188 (22)	1035188 (26)		1/8 x 1-1/4 roll pin
19	1034756 (7)	1034756 (8)	1034756 (10)	1034756 (12)		Feed roll, large
20	1034747RP	1034747RP	1034747RP	1034747RP	1	Spool, shifter Primary
21	103568548RP	103568560RP	103568572RP	103568584RP	1	Shaft, Primary agitator
22	1034692 (14)	1034692 (16)	1034692 (20)	1034692 (24)		3/16 x 3-1/2 roll pin
23	1035672RP	1035672RP	1035672RP	1035672RP	1	Lever, Primary & Native
24	1035199	1035199	1035199	1035199	1	Chain, Primary box, A2040
24A	FA419	FA419	FA419	FA419	1	#40 double pitch conn link
25	20A635	20A635	20A635	20A635	2	Lid handle
26	1001978*	1001978*	1001978*	1001978*	8	3/16 blind rivet, No. 63
27	1035643RP	1035643RP	1035643RP	1035643RP	1	Shield, frame
28	1035694RP	1035694RP	1035694RP	1035694RP	1	Brace, Native Primary
30	1008011*	1008011*	1008011*	1008011*	2	3/8 NC SQ nut w/ retainer
31	1035225	1035225	1035225	1035225	2	1/4 NC x .75 x .31 shoulder bolt
32	W70065*	W70065*	W70065*	W70065*	4	1/4 NC whiz nut
33	1034698 (7)	1034698 (8)	1034698 (10)	1034698 (12)		Spring
34	78285 (14)	78285 (16)	78285 (20)	78285 (24)		5/16 NC x 3/4 YD screw, BTN HD
35	W73163* (14)	W73163* (16)	W73163* (20)	W73163* (24)		5/16 NC flanged whiz nut
36	24409*	24409*	24409*	24409*	6	5/16 NC x 1 carriage bolt, ZP
37	14139*	14139*	14139*	14139*	6	5/16 NC flanged lock nut, HD ZP
38	6697*	6697*	6697*	6697*	23	3/8 NC x 1 carriage bolt, GR5 ZP
39	14350*	14350*	14350*	14350*	45	3/8 NC flanged lock nut
40	1035654RP	1035654RP	1035654RP	1035654RP	1	Sleeve, .56 x .75 x 2.34
41	1007294*	1007294*	1007294*	1007294*	1	1/2 NC x 4-1/2 carriage bolt, GR5 ZP
42	11900*	11900*	11900*	11900*	2	1/2 NC flanged lock nut
43	1035198	1035198	1035198	1035198	1	Chain, seeder main A2040 34 Link
43A	FA418	FA418	FA418	FA418	1	#40 single pitch conn link
44	1034744	1034744	1034744	1034744	1	Sprocket, 15/30
45	12296	12296	12296	12296	4	1/4-28 grease zerk
46	1034746	1034746	1034746	1034746	1	Sprocket, 15/40
47	1034735	1034735	1034735	1034735	1	Chain, seeder main A2040 36 link
47A	FA419	FA419	FA419	FA419	1	#40 double pitch conn link
48	SU910	SU910	SU910	SU910	2	.75 x 1.0 x .75 bearing needle
49	1257*	1257*	1257*	1257*	1	3/4 flat washer, ZP
50	35139	35139	35139	35139	1	.050 x .750 retainer ring
51	24611	24611	24611	24611	1	SMV sign

(Primary Seed Box parts list continued on Page 40)

PSS48, PSS60, PSS72, PSS84 PRIMARY SEED BOX PARTS LIST (CONTINUED)

REF	PSS48	PSS60	PSS72	PSS84	QTY	DESCRIPTION
52	1035651RP	1035651RP	1035651RP	1035651RP	2	Sleeve, .56 x .75 x .75
53	854*	854*	854*	854*	2	1/2 flat washer, ZP
54	27635*	27635*	27635*	27635*	1	1/2 NC x 3-1/2 carriage bolt
55	62043*	62043*	62043*	62043*	2	1/4 x 1-3/4 klik pin
56	976*	976*	976*	976*	1	3/8 NC x 1-1/2 cap screw GR5 ZP
57	1035233RP	1035233RP	1035233RP	1035233RP	4	Link, bent tray mount
58	103563148RP	103563160RP	103563172RP	103563184RP	1	Transition tray, front
59	103523148RP	103523160RP	103523172RP	103523184RP	1	Transition tray, rear
60	1035236RP	1035236RP	1035236RP	1035236RP	1	Calibration tray
61	1028375*	1028375*	1028375*	1028375*	3	3/8 push-on bolt
63	1035677RP	1035677RP	1035677RP	1035677RP	1	Mount, frame shield
64	1035655RP	1035655RP	1035655RP	1035655RP	1	Shield, primary
65	1035669A	1035669A	1035669A	1035669A	1	Sealant, 3M 760 hybrid black
66	W70067	W70067	W70067	W70067	1	.25 - 20 x .5 whiz bolt TRSS
67	5336*	5336*	5336*	5336*	1	1/4 flat washer, ZP
68	62521*	62521*	62521*	62521*	4	1/4 NC flanged lock nut
70	66840	66840	66840	66840	3	3/8 NC knob, 3 prong
71	20973*	20973*	20973*	20973*	20	3/8 NC x 1-1/4 carriage bolt GR5
72	1035690RP	1035690RP	1035690RP	1035690RP	2	Tab, reinforcement rear
73	1035657RP	1035657RP	1035657RP	1035657RP	1	Bracket, Primary only, LH
74	1035656RP	1035656RP	1035656RP	1035656RP	1	Bracket, Primary only, RH
75	1034753	1034753	1034753	1034753	2	Sprocket, idler w/ bearing
76	1035676	1035676	1035676	1035676	1	1/4 x 1-3/4 lock pin
77	1035203	1035203	1035203	1035203	1	Chain, A2040 Primary 17 link
77A	FA418	FA418	FA418	FA418	1	#40 single pitch conn link
77B	1002959	1002959	1002959	1002959	1	#40 single pitch offset link
82	-----	-----	-----	-----	1	Decal, mobile calibration procedure (included in item 86)
83	-----	-----	-----	-----	1	Decal, standard chain drive (included in item 86)
84	1038794RP	1038794RP	1038794RP	1038794RP	1	Pointer, Primary seed box
85	21941*	21941*	21941*	21941*	2	1/4 NC wing nut
86	1037499	1037499	1037499	1037499	1	Decal set, instructional, seeder
87	-----	-----	-----	-----	1	Decal, PSS Primary seed chart (included in item 86)
88	73758	73758	73758	73758	2	Cable, shield
89	565	565	565	565	1	Washer, 3/8 flat
90	10378	10378	10378	10378	2	Bolt 1/4 x 1 GR5
91	4378	4378	4378	4378	2	Washer, 5/16 flat
92	1038744	1038744	1038744	1038744	14	Plug 1/4"
93	602517	602517	602517	602517	2	Plug 3/8"
94	-----	-----	-----	-----	1	Decal, stationary calibration (included in item 86)
95	64812	64812	64812	64812	2	Bolt, crg 1/4 x 1/2

* Standard hardware, obtain locally

PSS48, PSS60, PSS72, PSS84 FRONT SPIKE ROLLER OPTION

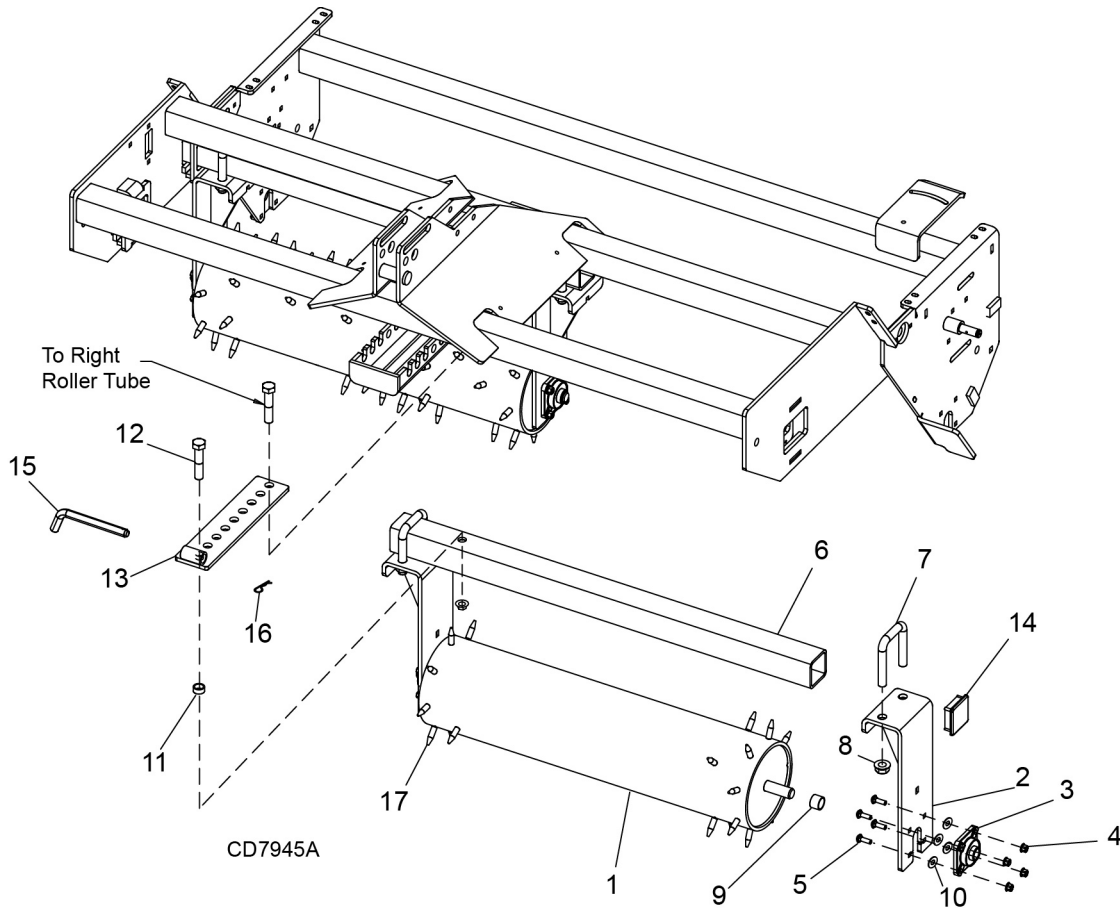

REF	PSS48	PSS60	PSS72	PSS84	QTY	DESCRIPTION
1	103876648RP	103876660RP	103876672RP	103876684RP	2	Front roller
2	1038680RP	1038680RP	1034677RP	1034677RP	4	Mount, bearing
3	20A920	20A920	20A920	20A920	4	1" bearing w/ housing
4	14350*	14350*	14350*	14350*	16	3/8 NC flanged lock nut
5	W301117*	W301117*	W301117*	W301117*	16	3/8 NC x 1-1/2 carriage bolt ZP
6	103866648RP	103866660RP	103468872RP	103468884RP	2	Tube, 3 x 3 x .25 x XX.XX
7	1034668	1034668	1034668	1034668	4	3/4 x 3.81 x 4.31 u - bolt
8	W302207*	W302207*	W302207*	W302207*	10	3/4 NC flanged lock nut
9	1035675RP	1035675RP	1035675RP	1035675RP	4	Sleeve, 1.03 x 1.25 x 0.88
10	1028375*	1028375*	1028375*	1028375*	4	3.8 push-on bolt retainer
11	1002943	1002943	1002943	1002943	2	Sleeve, .82 x 1.06 x .47
12	2376*	2376*	2376*	2376*	2	3/4 NC x 5 cap screw
13	1038740RP	1038740RP	1034690RP	1034690RP	1	Studded roller slide
14	1022507	1022507	1022507	1022507	2	Cap, 3 x 3 black plastic
15	1035646	1035646	1035646	1035646	1	3/4 x 6 pin, bent w/ clip
16	2688*	2688*	2688*	2688*	1	5/32 cotter pin
17	1002938	1002938	1002938	1002938	1	Replacement spikes (25 piece set)

* Standard hardware, obtain locally

PSS48, PSS60, PSS72, PSS84 LEGUME SEED BOX OPTION

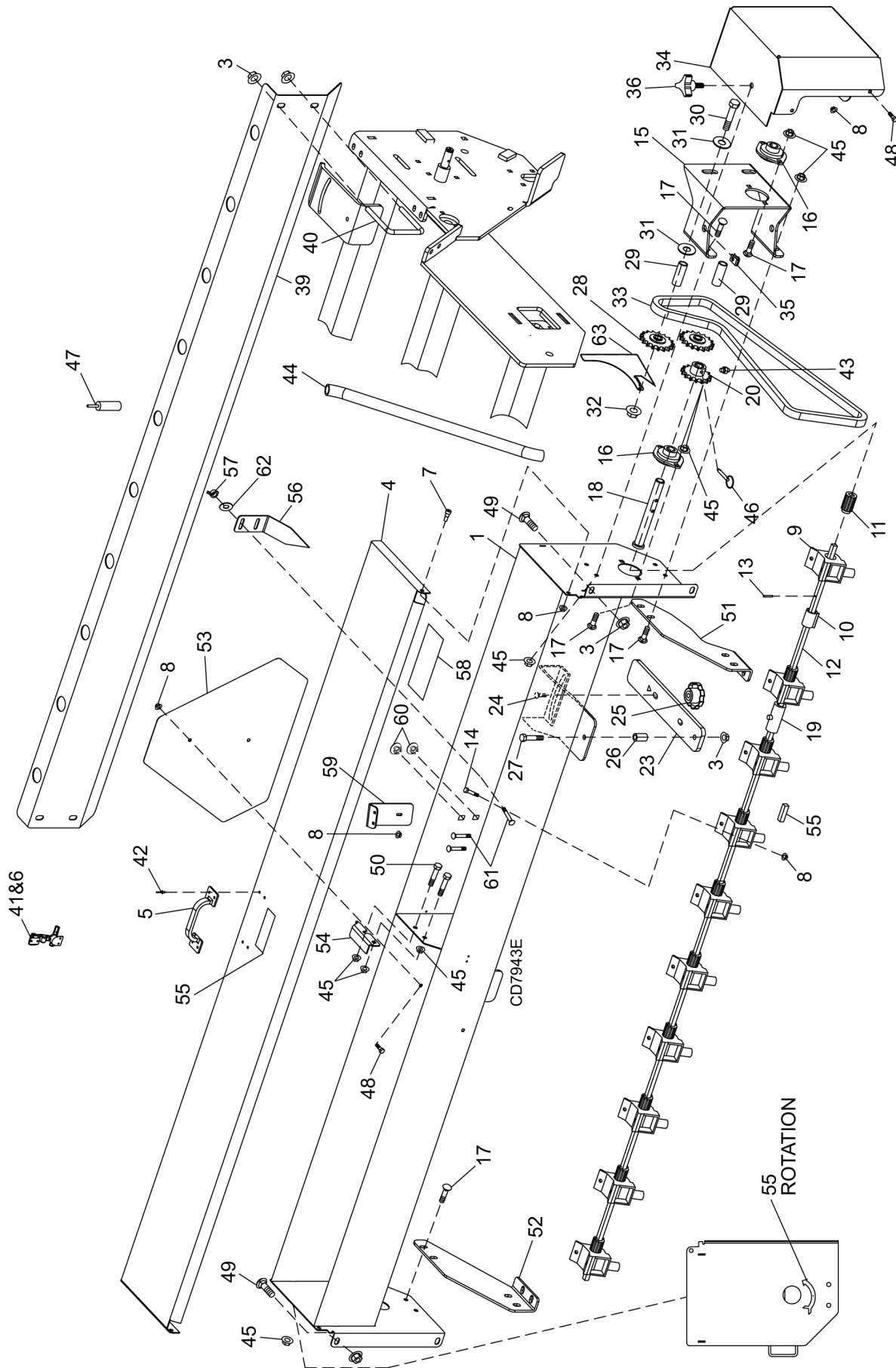

PSS48, PSS60, PSS72, PSS84 LEGUME SEED BOX PARTS LIST

REF	PSS48	PSS60	PSS72	PSS84	QTY	DESCRIPTION
1	103517848RP	103517860RP	103517872RP	103517884RP	1	Seedbox, Legume
3	14350*	14350*	14350*	14350*	9	3/8 NC flanged lock nut
4	103569948RP	103569960RP	103569972RP	103569984RP	1	Cover, Legume seedbox
5	20A635	20A635	20A635	20A635	1	Lid, handle
6	1001994*	1001994*	1001994*	1001994*	4	1/8 No. 43 blind rivet
7	1035225	1035225	1035225	1035225	2	1/4 NC x .75 x .31 shoulder bolt
8	W70065* (18)	W70065* (20)	W70065* (24)	W70065* (28)		1/4 NC whiz nut
9	1034695 (7)	1034695 (8)	1034695 (10)	1034695 (12)		Seedcup, small
10	1034696 (7)	1034696 (8)	1034696 (10)	1034696 (12)		Gate, small
11	1034697 (7)	1034697 (8)	1034697 (10)	1034697 (12)		Feed roll, small
12	103518648RP	103518660RP	103518672RP	103518684RP	1	Shaft, seedcup Legume
13	1035187 (16)	1035187 (18)	1035187 (22)	1035187 (26)		1/8 x 7/8 roll pin
14	W70067 (14)	W70067 (16)	W70067 (20)	W70067 (24)		25-20 x .5 whiz bolt TRSS/MR
15	1035195RP	1035195RP	1035195RP	1035195RP	1	Mount, bearing Legume
16	1034693	1034693	1034693	1034693	2	3/4 bearing, flangette
17	16148*	16148*	16148*	16148*	10	5/16 NC x 3/4 carriage bolt ZP
18	1034727RP	1034727RP	1034727RP	1034727RP	1	Tube, transmission
19	1035625RP	1035625RP	1035625RP	1035625RP	1	Sleeve, shifter
20	1034717	1034717	1034717	1034717	1	Sprocket
23	1035215RP	1035215RP	1035215RP	1035215RP	1	Lever, shifter
24	20973*	20973*	20973*	20973*	1	3/8 NC x 1-1/4 carriage bolt GR5
25	66840	66840	66840	66840	1	3/8 NC knob, 3 prong
26	1035632RP	1035632RP	1035632RP	1035632RP	1	Sleeve, .39 x .63 x 1.06
27	W300157*	W300157*	W300157*	W300157*	1	3/8 NC x 2-1/4 cap screw GR5 ZP
28	1034753	1034753	1034753	1034753	2	Sprocket IDL w/ bearing
29	1035667RP	1035667RP	1035667RP	1035667RP	2	Sleeve, .56 x .75 x 2.00
30	1637*	1637*	1637*	1637*	2	1/2 NC x 3-1/2 cap screw GR5 ZP
31	854*	854*	854*	854*	4	1/2 flat washer ZP
32	11900*	11900*	11900*	11900*	2	1/2 NC flanged lock nut
33	1035200	1035200	1035200	1035200	1	Chain A2040 54 link
33A	FA418	FA418	FA418	FA418	1	#40 single pitch conn link
34	1035641RP	1035641RP	1035641RP	1035641RP	1	Shield, legume
35	1033293*	1033293*	1033293*	1033293*	1	3/8 - 16 spring nut u-tapped
36	1033294	1033294	1033294	1033294	1	3/8 NC x 1.00 knob, 3 prong
39	103565348RP	103565360RP	103565372RP	103565384RP	1	Tray, Legume
40	1035662	1035662	1035662	1035662	2	3/8 x 3.43 x 3.56 u-bolt
41	1001975	1001975	1001975	1001975	1	Flex draw latch
42	1001978*	1001978*	1001978*	1001978*	4	3/16 No. 63 blind rivet
43	12296	12296	12296	12296	1	1/4 28 straight fitting, 15/32L
44	1035665RP (7)	1035665RP (8)	1035665RP (10)	1035665RP (12)		11/16 ID x 19-1/4 PVC tube
45	14139*	14139*	14139*	14139*	13	5/16 NC flanged lock nut HD ZP
46	1035244	1035244	1035244	1035244	1	1/4 x 1-1/5 pin, detent
47	1035669A	1035669A	1035669A	1035669A	1	Sealant, 3M 760 hybrid black
48	5337*	5337*	5337*	5337*	4	1/4 NC x 1/2 cap screw GR5
49	6697*	6697*	6697*	6697*	4	3/8 x 1 carriage bolt GR5 ZP
50	14562*	14562*	14562*	14562*	2	5/16 NC x 1 cap screw GR5
51	1035681RP	1035681RP	1035681RP	1035681RP	1	Brace, Legume LH
52	1035682RP	1035682RP	1035682RP	1035682RP	1	Brace, Legume RH
53	24611	24611	24611	24611	1	SMV sign
54	1035695RP	1035695RP	1035695RP	1035695RP	1	Brace, Legume lid
55	1037499RP	1037499RP	1037499RP	1037499RP	1	Decal set, instructional, seeder
56	1038793RP	1038793RP	1038793RP	1038793RP	1	Pointer, Legume
57	21941*	21941*	21941*	21941*	2	1/4 NC wing nut
58	1037383	1037383	1037383	1037383	1	Decal, PSS Legume seed chart
59	1035229RP	1035229RP	1035229RP	1035229RP	1	SMV bracket
60	602517	602517	602517	602517	2	Plug, 3/8"
61	64812	64812	64812	64812	2	Bolt, crg 1/4 x 1/2
62	5336	5336	5336	5336	2	1/4 flat washer ZP
63	602516RP	602516RP	602516RP	602516RP	1	Shield, chain end

* Standard hardware, obtain locally

PSS48, PSS60, PSS72, PSS84 NATIVE SEED BOX OPTION

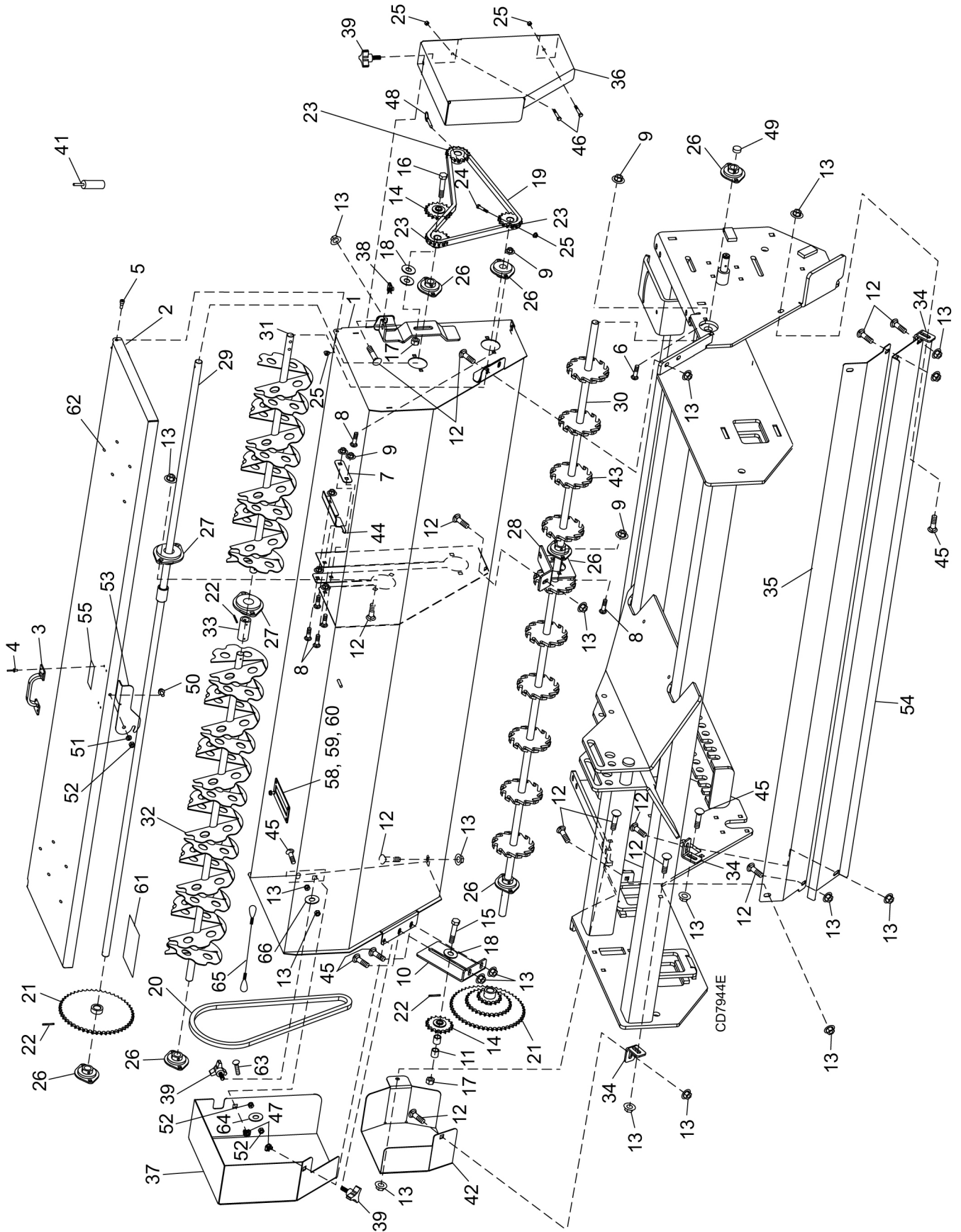

PSS48, PSS60, PSS72, PSS84 NATIVE SEED BOX PARTS LIST

REF	PSS48	PSS60	PSS72	PSS84	QTY	DESCRIPTION
1	103518048RP	103518060RP	103518072RP	103518084RP	1	Seedbox, Native
2	103569848RP	103569860RP	103569872RP	103569884RP	1	Cover, Native Primary seedbox
3	20A635	20A635	20A635	20A635	1	Lid, handle
4	1001978*	1001978*	1001978*	1001978*	4	3/16 No. 63 blind rivet
5	1035225	1035225	1035225	1035225	2	1/4 NC x .75 x .31 shoulder bolt
6	14458*	14458*	14458*	14458*	4	5/16 NC x 1-1/4 carriage bolt
7	1035197RP	1035197RP	1035197RP	1035197RP	2	Link
8	24409*	24409*	24409*	24409*	14	5/16 NC x 1 carriage bolt ZP
9	14139*	14139*	14139*	14139*	19	5/16 NC flanged lock nut HD ZP
10	1035636RP	1035636RP	1035636RP	1035636RP	1	Mount, idler RH
11	1035651RP	1035651RP	1035651RP	1035651RP	2	Sleeve, .56 x .75 x .75
12	6697*	6697*	6697*	6697*	19	3/8 x 1 carriage bolt GR5 ZP
13	14350*	14350*	14350*	14350*	25	3/8 NC flanged lock nut
14	1034753	1034753	1034753	1034753	2	Sprocket idler w/ bearing
15	3489*	3489*	3489*	3489*	1	1/2 NC x 3 cap screw GR5 ZP
16	3379*	3379*	3379*	3379*	1	1/2 NC x 1-1/2 cap screw GR5 ZP
17	11900*	11900*	11900*	11900*	2	1/2 NC flanged lock nut
18	854*	854*	854*	854*	3	1/2 flat washer ZP
19	1035201	1035201	1035201	1035201	1	Chain, A2040 left 46 links
19A	FA419	FA419	FA419	FA419	1	#40 double pitch conn link (not shown)
20	1035202	1035202	1035202	1035202	1	Chain, A2040 left 46 links
20A	FA418	FA418	FA418	FA418	1	#40 single pitch conn link (not shown)
21	1034737	1034737	1034737	1034737	2	Sprocket
22	1035188 (2)	1035188	1035188	1035188	4	1/8 x 1-1/4 roll pin
23	1034717	1034717	1034717	1034717	3	Sprocket RC40
24	62788*	62788*	62788*	62788*	2	1/4 NC x 1-1/2 cap screw GR5
25	6128*	6128*	6128*	6128*	6	1/4 NC lock nut
26	1034693	1034693	1034693	1034693	7	3/4 bearing, flangette
27	1034694 (1)	1034694	1034694	1034694	2	1-1/8 bearing flangette
28	1035245RP	1035245RP	1035245RP	1035245RP	1	3rd picker wheel bearing mount
29	103521748RP	103521760RP	103521772RP	103521784RP	1	Shaft PT
30	103518348RP	103518360RP	103518372RP	103518384RP	1	Shaft picker wheel
31	103467948RP	103467972LRP	103467972LRP	103467984LRP	1	Shaft agitator, LH
32	-----	103467960RRP	103467972RRP	103467972RRP	1	Shaft agitator, RH
33	-----	1035241	1035241	1035241	1	Coupler agitator
34	1035232RP	1035232RP	1035232RP	1035232RP	3	Mount, transition tray
35	103523048RP	103523060RP	103523072RP	103523084RP	1	Transition tray
36	1035644RP	1035644RP	1035644RP	1035644RP	1	Shield, LH
37	1035645RP	1035645RP	1035645RP	1035645RP	1	Shield, RH
38	1033293	1033293	1033293	1033293	1	3/8 - 16 spring nut u-tapped
39	1033294	1033294	1033294	1033294	3	3/8 NC x 1.00 knob, 3 prong
41	1035669A	1035669A	1035669A	1035669A	1	Sealant, 3M 760 hybrid black
42	1035668RP	1035668RP	1035668RP	1035668RP	1	Shield, right bottom
43	1034691 (7)	1034691 (8)	1034691 (10)	1034691 (12)	1	Picker wheel
44	1036386RP	1036386RP	1036386RP	1036386RP	1	Brace, native
45	20973*	20973*	20973*	20973*	5	3/8 NC x 1-1/4 carriage bolt GR5
46	5337*	5337*	5337*	5337*	2	1/4 NC x 1/2 cap screw GR5
47	1008011*	1008011*	1008011*	1008011*	2	3/8 NC SQ nut w/ retainer
48	1035244	1035244	1035244	1035244	1	1/4 x 1-1/5 pin w/ 3/4 ring
49	1035652	1035652	1035652	1035652	1	Cap, vinyl black 3/4 - 13/16 OD 1/2
50	W70067	W70067	W70067	W70067	1	.25-20 x .5 whiz bolt TRSS
51	5336*	5336*	5336*	5336*	1	1/4 flat washer ZP
52	62521*	62521*	62521*	62521*	1	1/4 NC flanged lock nut
53	1035672RP	1035672RP	1035672RP	1035672RP	1	Lever, Primary & Native cover
54	103563148RP	103563160RP	103563172RP	103563184RP	1	Transition tray, front
55	1037499	1037499	1037499	1037499	1	Decal set, instructional, seeder
56	1036397	1036398	1036399	1036400	1	Kit, gasket native seed box (not shown)
58	1036375 (7)	1036375 (8)	1036375 (10)	1036375 (12)	1	Gasket
59	1036374RP (7)	1036374RP (8)	1036374RP (10)	1036374RP (12)	1	Plate, retainer
60	78162 (28)*	78162 (32)*	78162 (40)*	78162 (48)*	1	#10 NC self-tapping screw
61	1037384	1037384	1037384	1037384	1	Decal, PSS Native seed chart

(Native Seed Box parts list continued on Page 46)

PSS48, PSS60, PSS72, PSS84 NATIVE SEED BOX PARTS LIST (CONTINUED)

REF	PSS48	PSS60	PSS72	PSS84	QTY	DESCRIPTION
62	1038744	1038744	1038744	1038744	10	Plug, 1/4"
63	10378	10378	10378	10378	1	Bolt, 1/4 x 1
64	4378	4378	4378	4378	1	Washer, 5/16 flat
65	73758	73758	73758	73758	1	Cable, shield
66	565	565	565	565	1	Washer, 3/8 flat
					*	Standard hardware, obtain locally

PSS48, PSS60, PSS72, PSS84 FRONT DISC OPTION (SERIAL NO. 1285001 & ABOVE)

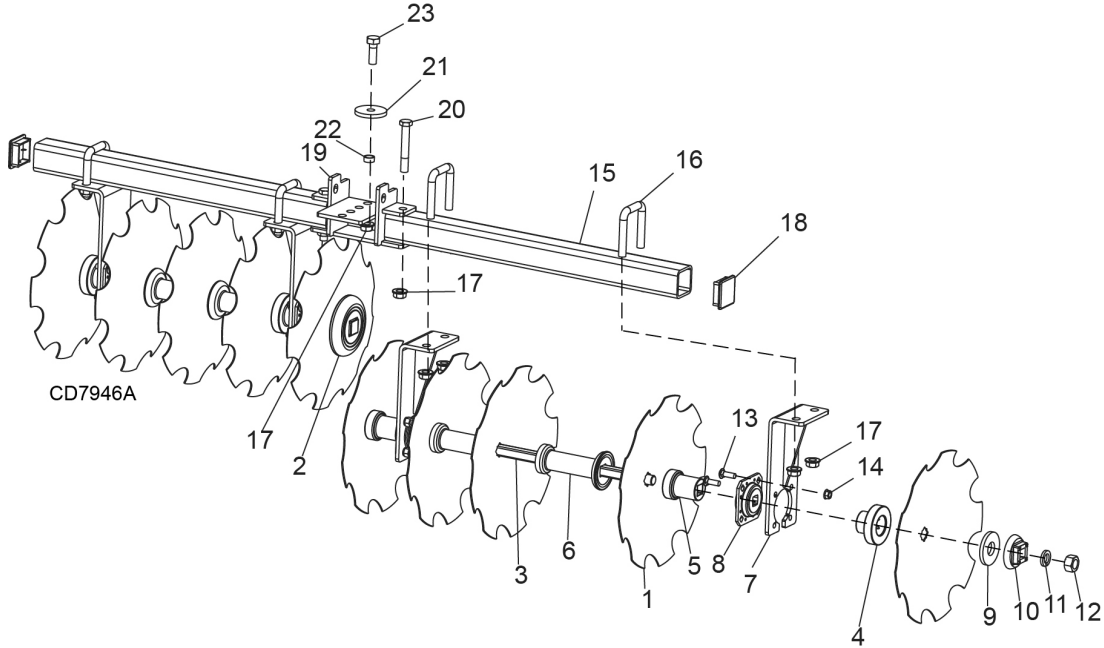

REF	PSS48	PSS60	PSS72	PSS84	QTY	DESCRIPTION
1	1038696 (8)	1038696 (8)	-----	-----		16" notched blade (for PSS48 & PSS60)
1	-----	-----	1011274 (10)	1011274 (12)		18" notched blade (for PSS72 & PSS84)
2	1011322	1011322	1011322	1011322	2	Washer, disc bumper
3	1011299	1011299	1011277	1011279	2	Axle, disc
4	1034764	1034764	1011324	1034764	4	Spool, spacer, 2-3/8 or 2
5	1034763	1034763	1011323	1034763	4	Spool, spacer, 3-5/8 or 3-1/4
6	1011349 (2)	1011349 (2)	1011349 (4)	1011349 (6)	6	Spool, spacer 7-3/8
7	1038674RP	1038674RP	1034674RP	1034674RP	4	Disc mount bearing
8	1022500	1022500	1022500	1022500	4	1 SQ flanged bearing assembly
9			1022544RP (2)	1022544RP (8)		1.41 x 3.50 x .375 flat washer
10	1022501	1022501	1022501	1022501	2	End cap washer, disc
11	3689*	3689*	3689*	3689*	2	1" standard lock washer
12	3132*	3132*	3132*	3132*	2	1 NC hex nut ZP
13	29893*	29893*	29893*	29893*	16	1/2 NC x 1-1/2 carriage bolt HT
14	11900*	11900*	11900*	11900*	16	1/2 NC flanged lock nut
15	103869748RP	103869760RP	103467172RP	103467184RP	2	Tube, 3 x 3 x .25 x XX.XX
16	1034668	1034668	1034668	1034668	4	3/4 x 3.81 x 4.31 u-bolt
17	W302207	W302207	W302207	W302207	11	3/4 NC flanged lock nut
18	1022507	1022507	1022507	1022507	2	3 x 3 cap, black plastic
19	1034701RP	1034701RP	1034701RP	1034701RP	1	Disc slide
20	12558*	12558*	-----	-----	2	3/4 NC x 4-1/2 cap screw (for PSS48 & PSS60)
20	-----	-----	2376*	2376*	2	3/4 NC x 5 cap screw (for PSS72 & PSS84)
21	1035673RP	1035673RP	1035673RP	1035673RP	1	.78 x 3.25 x .38 washer
22	1002943	1002943	1002943	1002943	1	Sleeve, .82 x 1.06 x .47
23	13759*	13759*	13759*	13759*	1	3/4 NC x 2-1/4 cap screw GR5 ZP
					*	Standard hardware, obtain locally

PSS48, PSS60, PSS72, PSS84 FRONT DISC OPTION (SERIAL NO. 1285000 & BELOW)

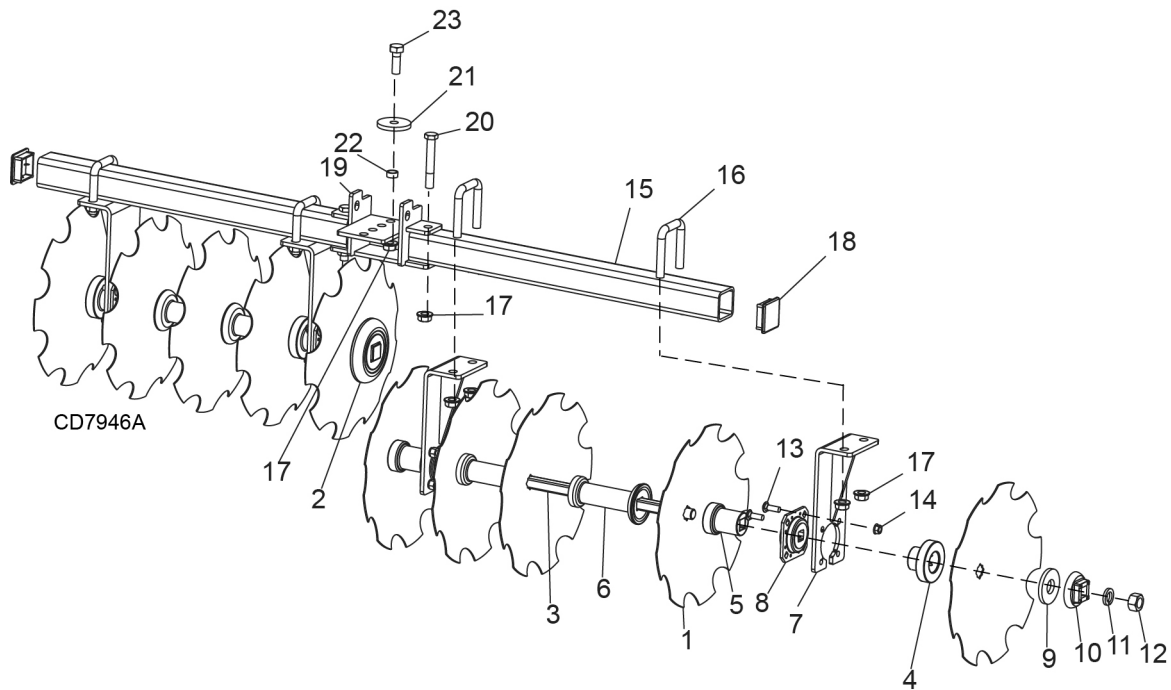

REF	PSS48	PSS60	PSS72	PSS84	QTY	DESCRIPTION
1	1011274 (6)	1011274 (8)	1011274 (10)	1011274 (12)		18" notched blade
2	1011322	1011322	1011322	1011322	2	Washer, disc bumper
3	1035248	1011299	1011277	1011279	2	Axle, disc
4	1011324	1011324	1011324	1034764	4	Spool, spacer, 2-3/8 or 2
5	1011323	1011323	1011323	1034763	4	Spool, spacer, 3-5/8 or 3-1/4
6	1011349	1011349	1011349	1011349	6	Spool, spacer 7-3/8
7	1034674RP	1034674RP	1034674RP	1034674RP	4	Disc mount bearing
8	1022500	1022500	1022500	1022500	4	1 SQ flanged bearing assembly
9			1022544 (2)	1022544 (8)		1.41 x 3.50 x .375 flat washer
10	1022501	1022501	1022501	1022501	2	End cap washer, disc
11	3689*	3689*	3689*	3689*	2	1" standard lock washer
12	3132*	3132*	3132*	3132*	2	1 NC hex nut ZP
13	29893*	29893*	29893*	29893*	16	1/2 NC x 1-1/2 carriage bolt HT
14	11900*	11900*	11900*	11900*	16	1/2 NC flanged lock nut
15	103467148	103467160	103467172RP	103467184RP	2	Tube, 3 x 3 x .25 x XX.XX
16	1034668	1034668	1034668	1034668	4	3/4 x 3.81 x 4.31 u-bolt
17	W302207	W302207	W302207	W302207	11	3/4 NC flanged lock nut
18	1022507	1022507	1022507	1022507	2	3 x 3 cap, black plastic
19	1034701RP	1034701RP	1034701RP	1034701RP	1	Disc slide
20	2376*	2376*	2376*	2376*	2	3/4 NC x 5 cap screw
21	1035673RP	1035673RP	1035673RP	1035673RP	1	.78 x 3.25 x .38 washer
22	1002943	1002943	1002943	1002943	1	Sleeve, .82 x 1.06 x .47
23	13759*	13759*	13759*	13759*	1	3/4 NC x 2-1/4 cap screw GR5 ZP

* Standard hardware, obtain locally

PSS48, PSS60, PSS72, PSS84 CAST IRON CULTIPACKER OPTION

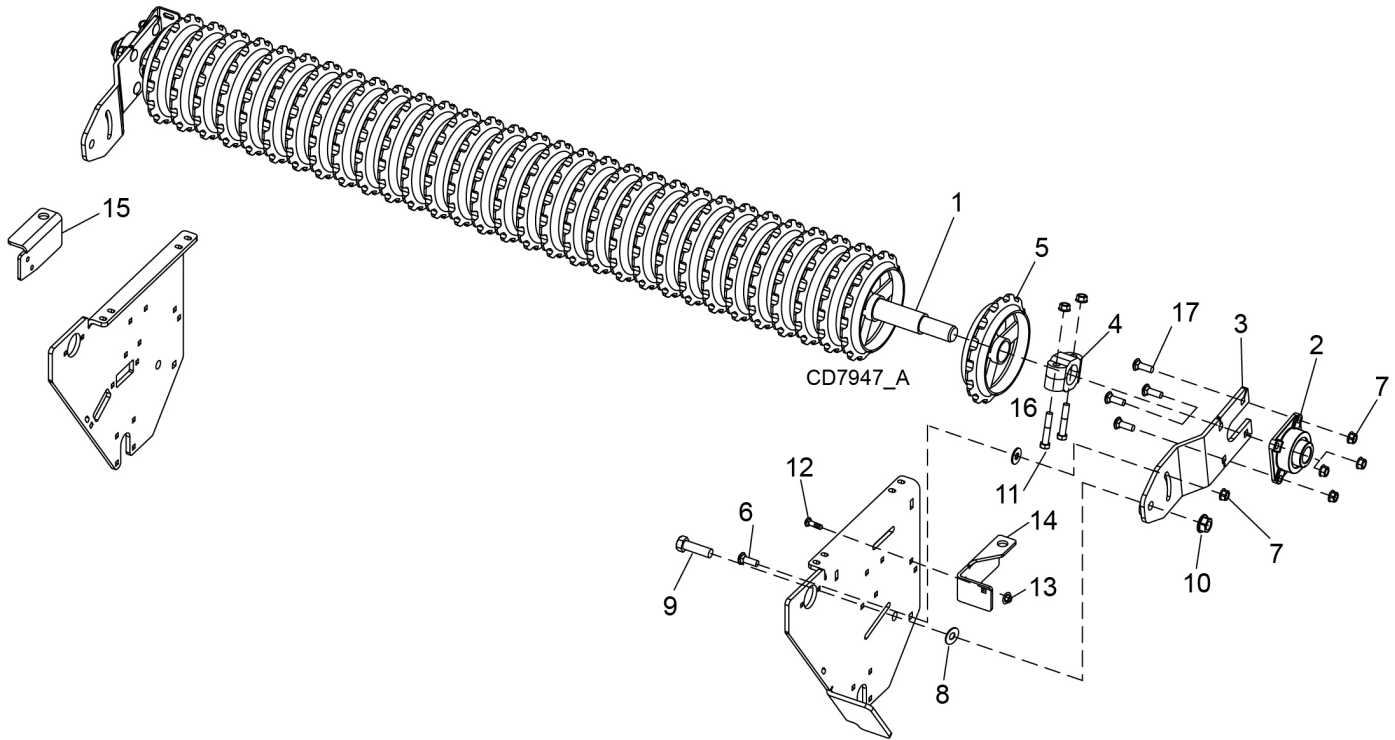

REF	PSS48	PSS60	PSS72	PSS84	QTY	DESCRIPTION
1	103465048RP	103465060RP	103465072RP	103465084RP	1	Shaft, cultipacker
2	1033740	1033740	1033740	1033740	2	1.38 flanged 4 bolt bearing
3	1035210RP	1035210RP	1035210RP	1035210RP	2	Mount, cultipacker
4	1034676	1034676	1034676	1034676	4	1-3/4 clamp
5	1034651 (22)	1034651 (26)	1034651 (32)	1034651 (37)		Wheel
6	12735*	12735*	12735*	12735*	2	1/2 NC x 1-3/4 carriage bolt HT
7	11900*	11900*	11900*	11900*	14	1/2 NC flanged lock nut
8	1257*	1257*	1257*	1257*	2	3/4 flat washer ZP
9	735*	735*	735*	735*	2	3/4 NC x 2 cap screw GR5
10	W302207*	W302207*	W302207*	W302207*	2	3/4 NC flanged lock nut
11	3489*	3489*	3489*	3489*	4	1/2 NC x 3 cap screw GR5
12	20973*	20973*	20973*	20973*	2	3/8 NC x 1-1/4 carriage bolt
13	14350*	14350*	14350*	14350*	4	3/8 NC flanged lock nut
14	103869225RP	103869225RP	103869225RP	103869225RP	1	Mount, cultipacker stop, LH
15	1038693RP	1038693RP	1038693RP	1038693RP	1	Mount, cultipacker stop, RH
16	854*	854*	854*	854*	2	1/2 std flat washer
17	10284	10284	10284	10284	8	1/2 NC x 2 carriage bolt GR5 ZP

* Standard hardware, obtain locally

PSS48, PSS60, PSS72, PSS84 NYLON CULTIPACKER OPTION

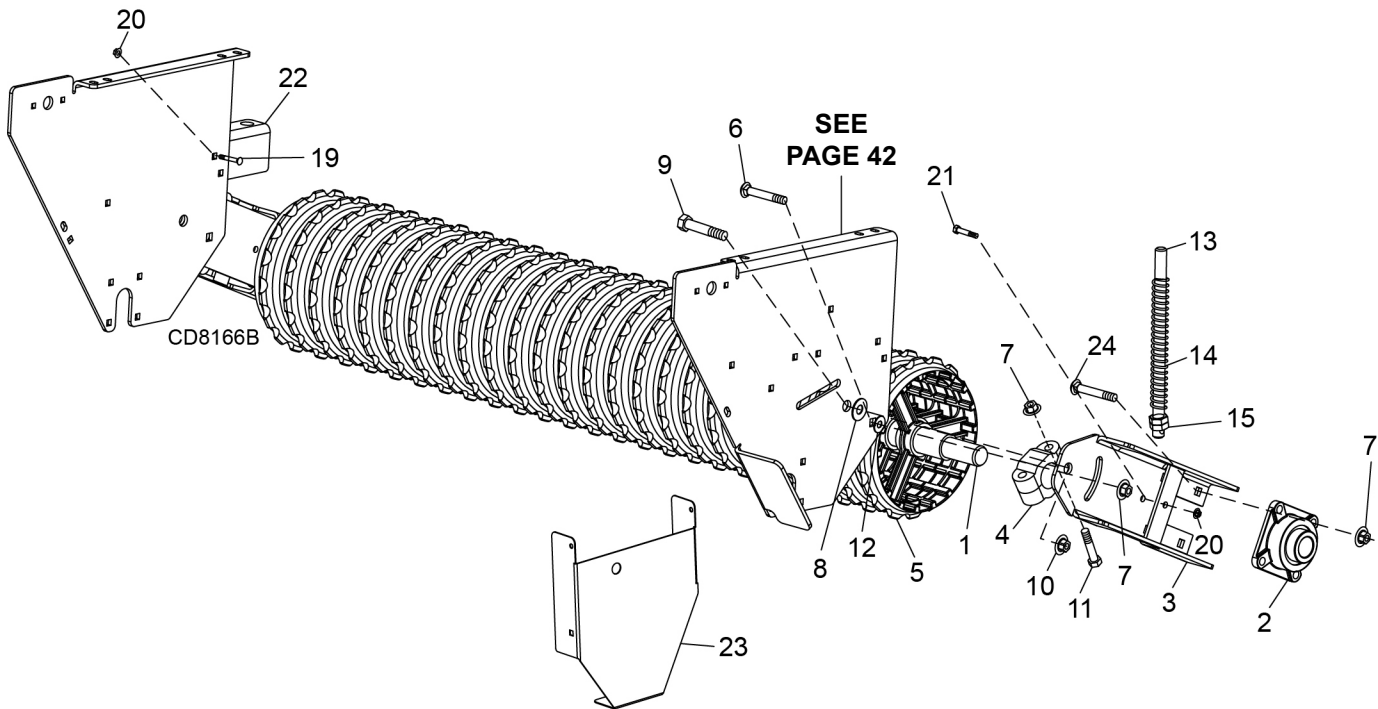

REF	PSS48	PSS60	PSS72	PSS84	QTY	DESCRIPTION
1	103878048RP	103878060RP	103878072RP	103878084RP	1	Shaft, cultipacker
2	1033740	1033740	1033740	1033740	2	1.38 flanged 4 bolt bearing
3	1038699RP	1038699RP	1038699RP	1038699RP	2	Arm, cultipacker
4	1034676	1034676	1034676	1034676	4	1-3/4 clamp
5	1038781P (20)	1038781P (25)	1038781P (30)	1038781P (35)		Cultipacker, plastic
6	12735*	12735*	12735*	12735*	2	1/2 NC x 1-3/4 carriage bolt HT
7	11900*	11900*	11900*	11900*	14	1/2 NC flanged lock nut
8	1257*	1257*	1257*	1257*	2	3/4 flat washer ZP
9	735*	735*	735*	735*	2	3/4 NC x 2 cap screw GR5
10	W302207*	W302207*	W302207*	W302207*	2	3/4 NC flanged lock nut
11	3489*	3489*	3489*	3489*	4	1/2 NC x 3 cap screw GR5
12	854*	854*	854*	854*	2	1/2 flat washer, ZP
13	20A111	20A111	20A111	20A111	2	Stud, spring
14	20A125	20A125	20A125	20A125	2	Spring
15	29485*	29485*	29485*	29485*	4	3/4 NC jam nut ZP
19	20973*	20973*	20973*	20973*	2	3/8 NC x 1-1/4 carriage bolt GR5 ZP
20	14350*	14350*	14350*	14350*	4	3/8 NC flanged lock nut
21	7747*	7747*	7747*	7747*	2	3/8 NC x 3 cap screw GR5
22	1038693RP	1038693RP	1038693RP	1038693RP	1	Mount, cultipacker stop RH
23	1036411RP	1036411RP	1036411RP	1036411RP	1	Shield, chain
24	10284	10284	10284	10284	8	1/2 NC x 2 carriage bolt GR5 ZP

* Standard hardware, obtain locally

PSS48, PSS60, PSS72, PSS84 SCRAPERS SPIKED ROLLER OPTION

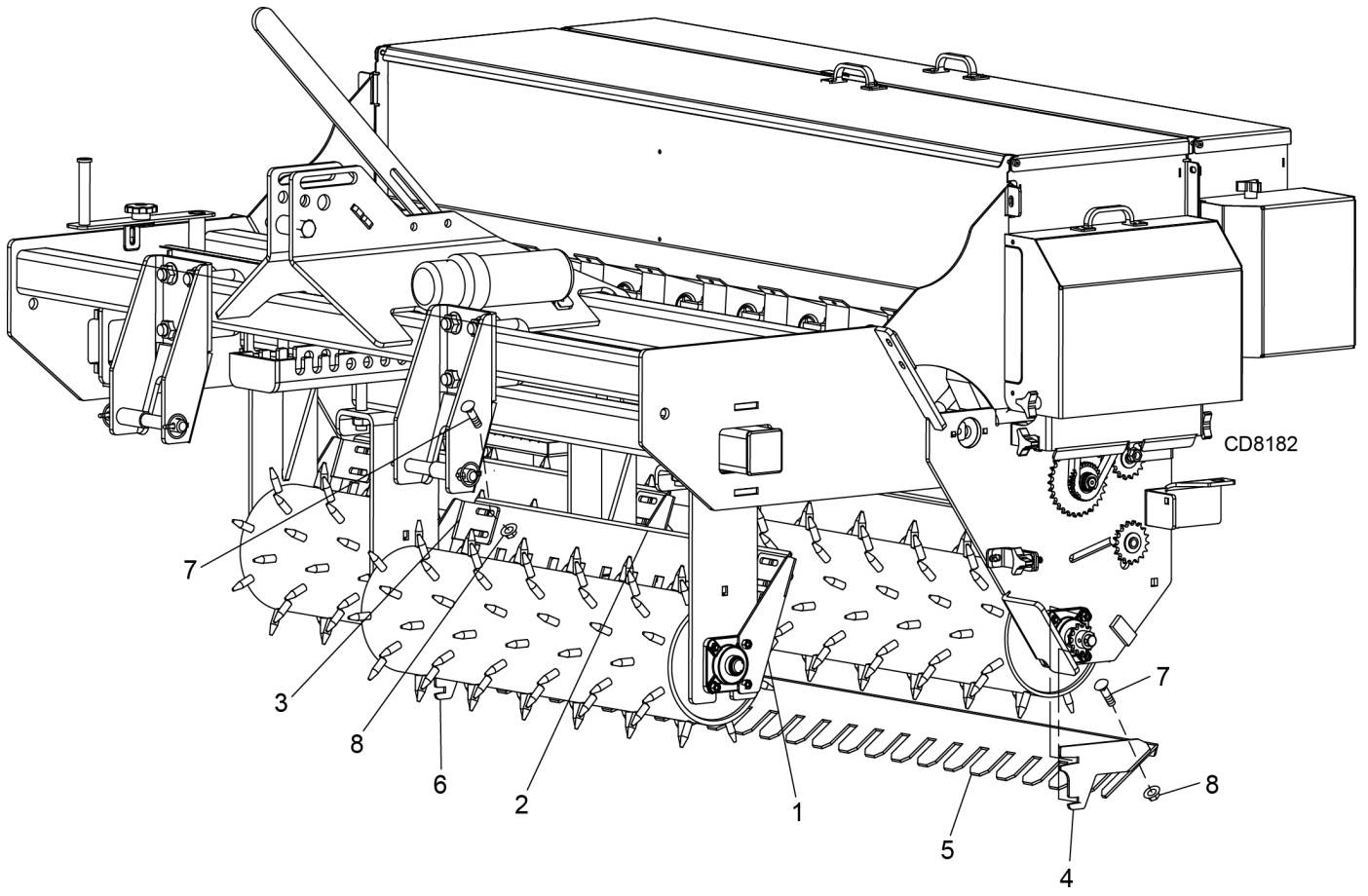

REF	PSS48	PSS60	PSS72	PSS84	QTY	DESCRIPTION
1	1036465RP	1036465RP	1036465RP	1036465RP	2	Scraper, mount, spiked front, LH
2	103642948RP	103642960RP	103642972RP	103642984RP	2	Scraper, spiked front
3	1036464RP	1036464RP	1036464RP	1036464RP	2	Scraper, mount, spiked front, RH
4	1036455RP	1036455RP	1036455RP	1036455RP	1	Scraper, mount, middle LH
5	103642548RP	103642560RP	103642572RP	103642584RP	1	Scraper, spiked drive roller
6	1036454RP	1036454RP	1036454RP	1036454RP	1	Scraper, mount, middle RH
7	14350*	14350*	14350*	14350*	12	3/8 NC flanged lock nut
8	6697*	6697*	6697*	6697*	12	3/8 NC x 1 carriage bolt GR5

* Standard hardware, obtain locally

PSS48, PSS60, PSS72, PSS84 SCRAPERS - DISC & SPIKED DRIVE ROLLER OPTION

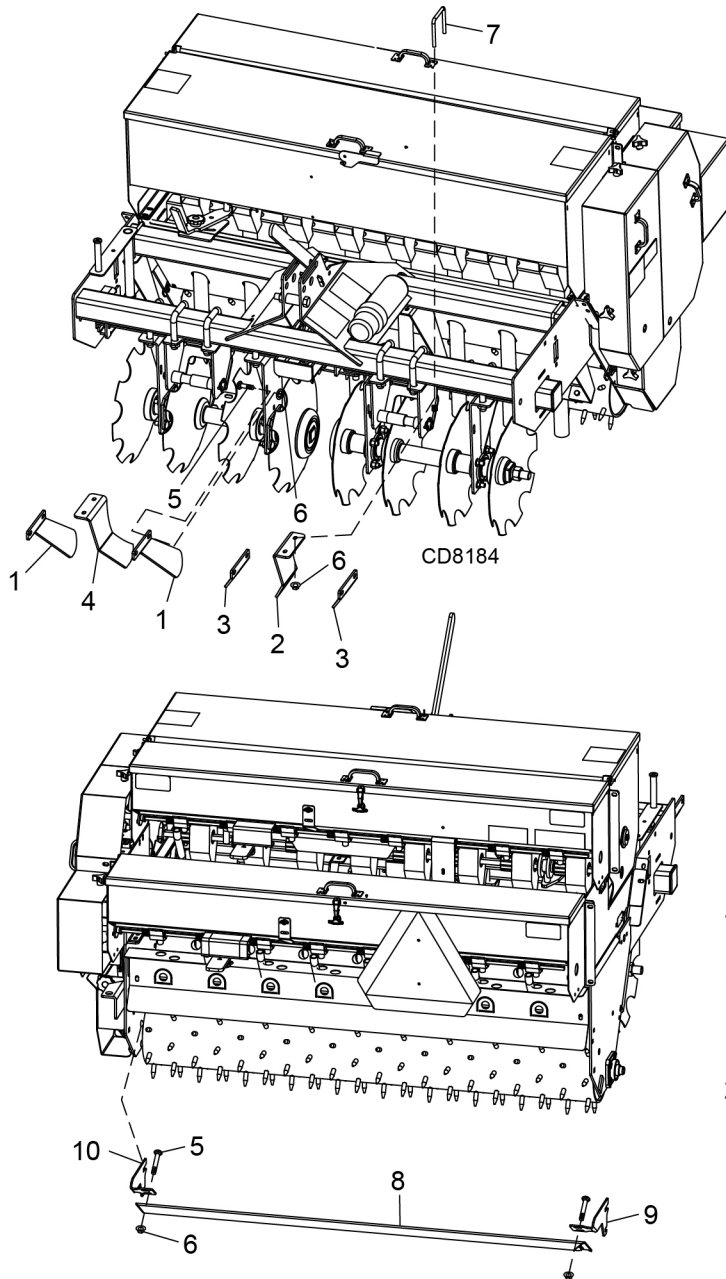

SCRAPER MOUNTS ATTACH TO MIDDLE BEARING CARRIAGE BOLTS ON INSIDE OF FRAME

1. LOOSEN NUTS AND TAP CARRIAGE BOLTS IN PLACING MOUNT UNDERNEATH BOLT HEAD
2. RETIGHTEN BOLTS AFTER INSTALLATION

REF	PSS48	PSS60	PSS72	PSS84	QTY	DESCRIPTION
1	1038754RP	1038754RP	1038754RP	1038754RP	2	Scraper, disc mount, RH
2	1038752RP (1)	1038752RP(1)	1038752RP (2)	1038752RP (3)		Scraper, disc link, LH
3	1038751RP	1038751RP	1038751RP	1038751RP	2	Scraper, disc mount, LH
4	1038753RP (1)	1038753RP (1)	1038753RP (2)	1038753RP (3)		Scraper, disc link, RH
5	6697*	6697*	6697*	6697*	12	3/8 NC x 1 carriage bolt, GR5
6	14350* (16)	14350* (16)	14350* (20)	14350* (24)		3/8 NC flanged lock nut
7	1035662 (2)	1035662 (2)	1035662 (4)	1035662 (6)		U-bolt, 3/8 NC x 3-7/16 x 3-5/8
8	103642548RP	103642560RP	103642572RP	103642584RP	1	Scraper, spiked drive roller
9	1036454RP	1036454RP	1036454RP	1036454RP	1	Mount, scraper drive roller, RH
10	1036455RP	1036455RP	1036455RP	1036455RP	1	Mount, scraper drive roller, LH

* Standard hardware, obtain locally

PSS48, PSS60, PSS72, PSS84 SCRAPERS - CAST IRON CULTIPACKER OPTION

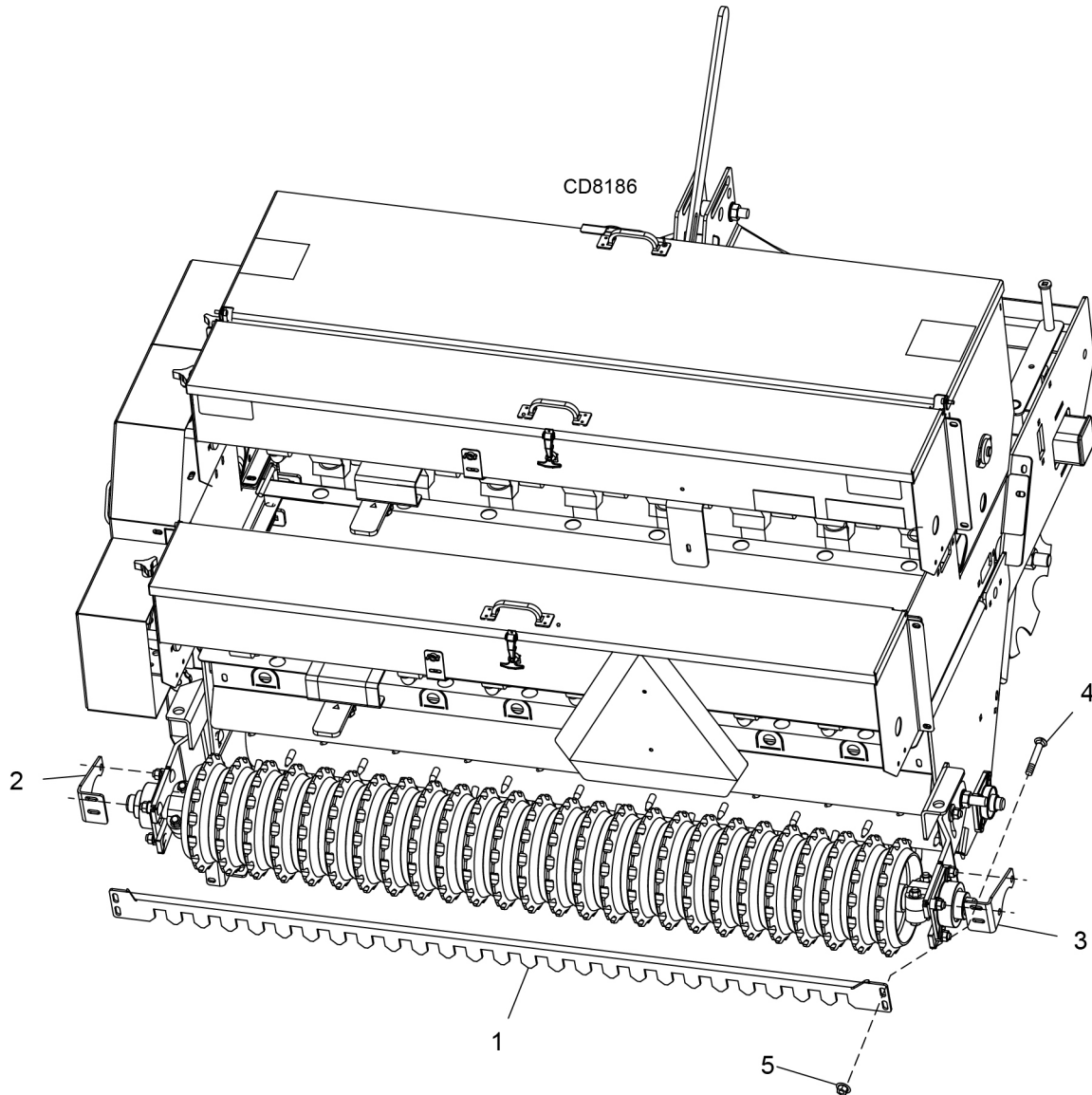

REF	PSS48	PSS60	PSS72	PSS84	QTY	DESCRIPTION
1	103642648RP	103642660RP	103642672RP	103642684RP	1	Scraper, cultipacker, cast iron
2	1036427RP	1036427RP	1036427RP	1036427RP	1	Mount, scraper, cultipacker, cast iron, LH
3	1036428RP	1036428RP	1036428RP	1036428RP	1	Mount, scraper, cultipacker, cast iron, RH
4	6697*	6697*	6697*	6697*	4	3/8 NC x 1 carriage bolt, GR5
5	14350*	14350*	14350*	14350*	4	3/8 NC flanged lock nut

* Standard hardware, obtain locally

PSS48, PSS60, PSS72, PSS84 SCRAPER - NYLON CULTIPACKER OPTION

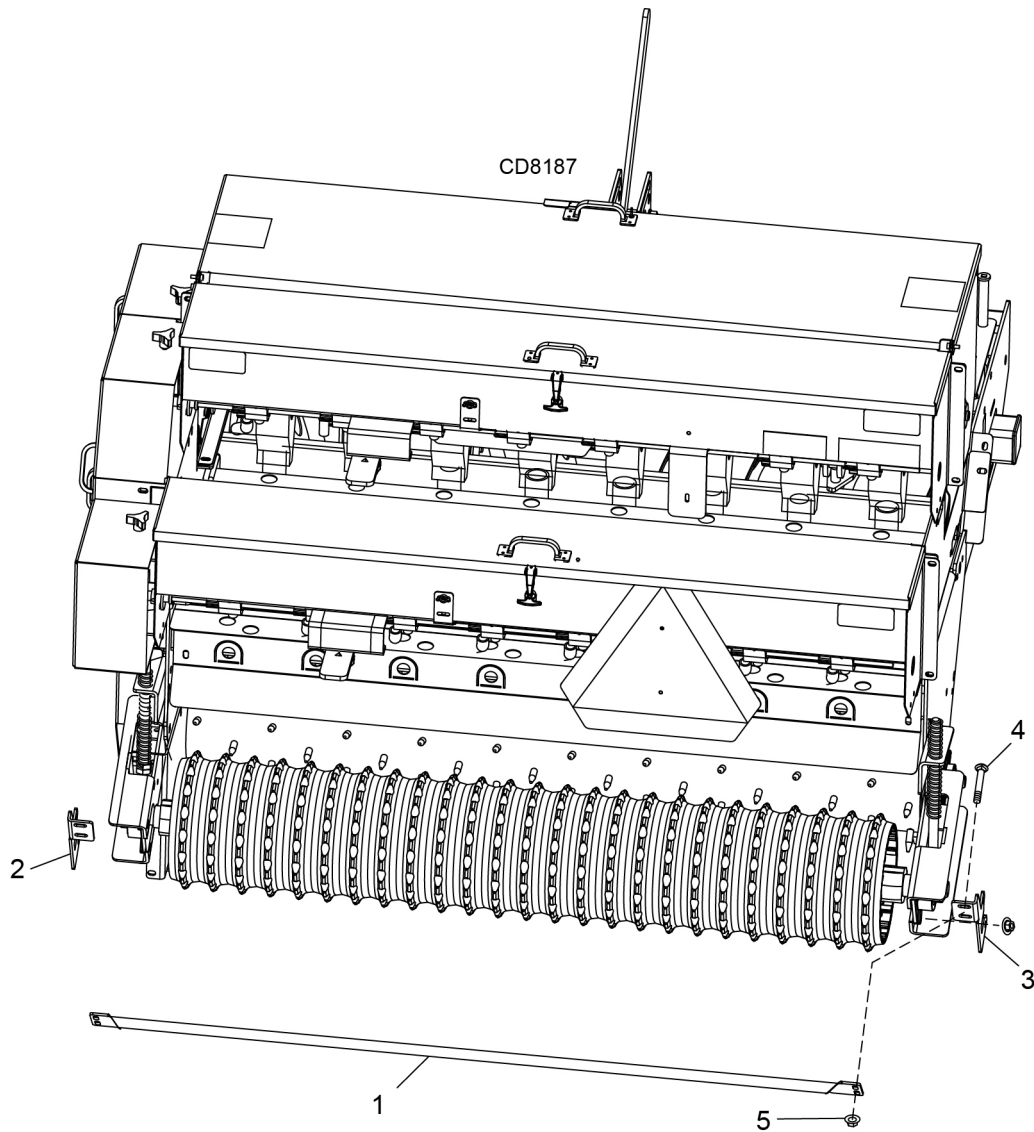

REF	PSS48	PSS60	PSS72	PSS84	QTY	DESCRIPTION
1	103879248RP	103879260RP	103879272RP	103879284RP	1	Scraper, cultipacker, nylon - rear
2	1038797RP	1038797RP	1038797RP	1038797RP	1	Mount, scraper, cultipacker, nylon LH
3	1038798RP	1038798RP	1038798RP	1038798RP	1	Mount, scraper, cultipacker, nylon RH
4	6697*	6697*	6697*	6697*	4	3/8 NC x 1 carriage bolt, GR5
5	14350*	14350*	14350*	14350*	4	3/8 NC flanged lock nut

* Standard hardware, obtain locally

PSS48, PSS60, PSS72, PSS84 ROW UNITS

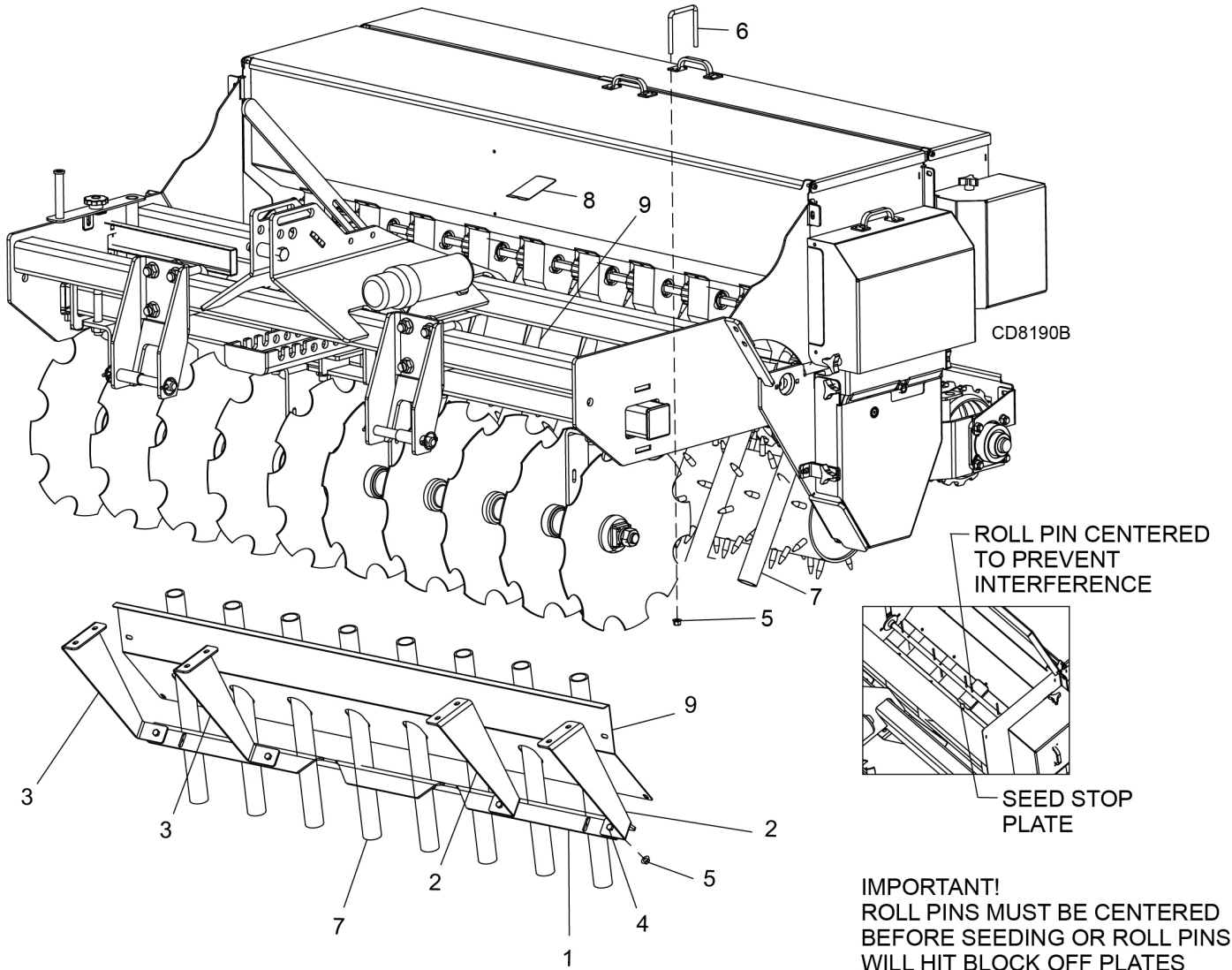

REF	PSS48	PSS60	PSS72	PSS84	QTY	DESCRIPTION
1	103877148RP	103877160RP	103877172RP	103877184RP	1	Guide, row unit
2	1038769RP (1)	1038769RP (1)	1038769RP (2)	1038769RP (2)		Mount, row guide, LH
3	1038768RP (1)	1038768RP (1)	1038768RP (2)	1038768RP (2)		Mount, row guide, RH
4	839* (2)	839* (2)	839* (4)	839* (4)		3/8 NC x 1 cap screw, GR5
5	14350* (6)	14350* (6)	14350* (12)	14350* (12)		3/8 NC flanged lock nut
6	1035662 (2)	1035662 (2)	1035662 (4)	1035662 (4)		U-bolt, 3/8 NC x 3-7/16 x 3-5/8
7	1038775RP (7)	1038775RP (8)	1038775RP (10)	1038775RP (12)		Tube, PVC, 1-1/2 x 23
8	1038658	1038658	1038658	1038658		Seed stop, 12 pack
9	103635748RP	103635760RP	103635772RP	103635784RP	1	Transition tray, front w/ slots

* Standard hardware, obtain locally

1036395 SLOW CHAIN DRIVE ACCESSORY PARTS
(see Figure 28 in OPERATION)

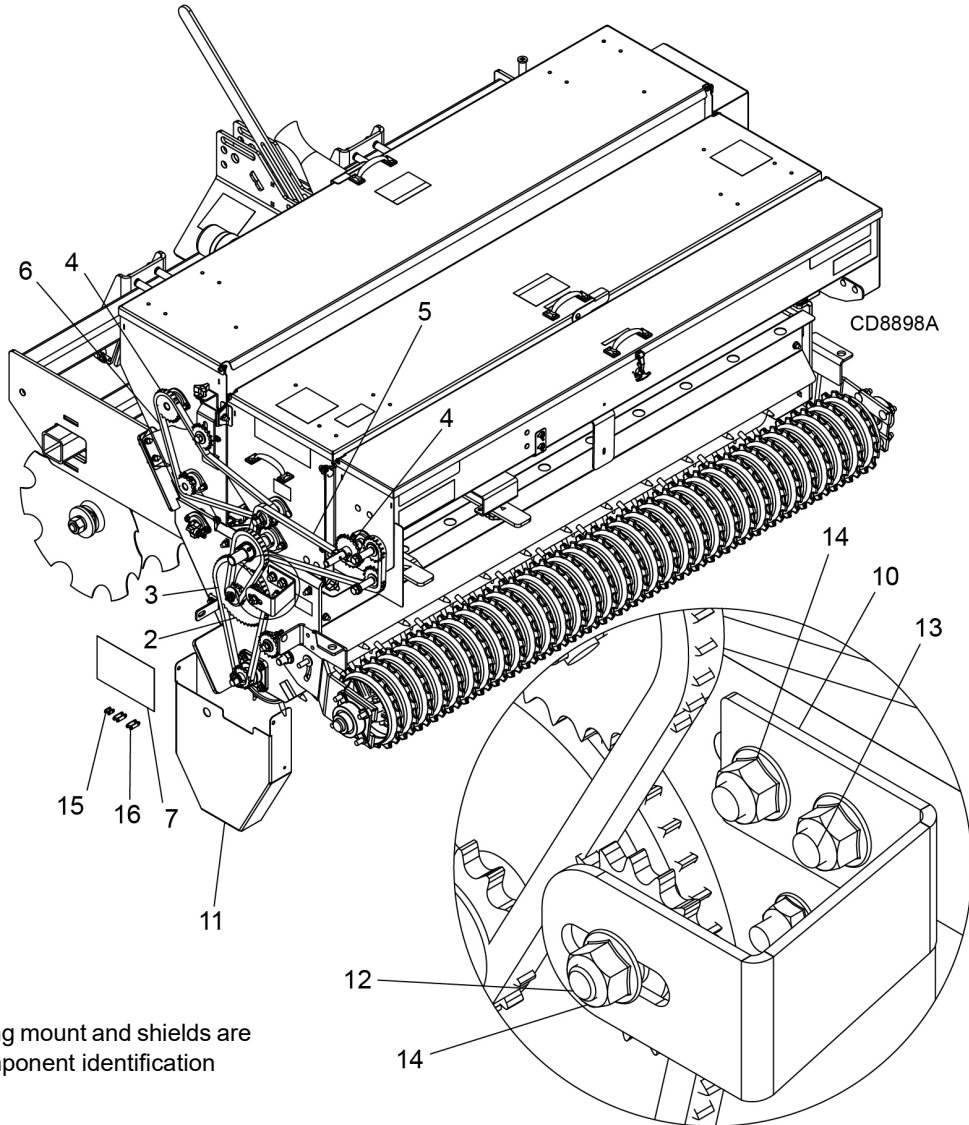

NOTE: Bearing mount and shields are hidden for component identification

REF	PART	QTY	DESCRIPTION
2	1036379	1	WA, sprocket RC40 15-50 in. bore
3	1036402	1	Chain, seeder main A2040 40 link
4	1036422	2	Sprocket, RC40 22th 3/4 bore
5	1036404	1	Chain, Legume box A2040 54 links
6	1036405	1	Chain, A2040 Native left 48 link
7	1036388	1	Dcl, slow chain drive PSS
9	SU910	2	Bearing, needle .75 x 1.0 x .75 (Not shown; in item 2)
10	1037468RP	1	Channel, super slow kit Idler
11	1038756RP	1	Shield, frame notched
12	3379	1	HHCS 1/2 NC x 1-1/2 GR5 ZP
13	2615	2	Bolt crg 1/2 NC x 1-1/4 GR5
14	11900	3	Nut lock 1/2 NC flange
15	FA418	1	Link, RLR chain #40 single conn link
16	FA419	2	Link, RLR chain #2040 double pitch conn

1036396 SUPER SLOW CHAIN DRIVE ACCESSORY PARTS
(see Figure 29 in OPERATION)

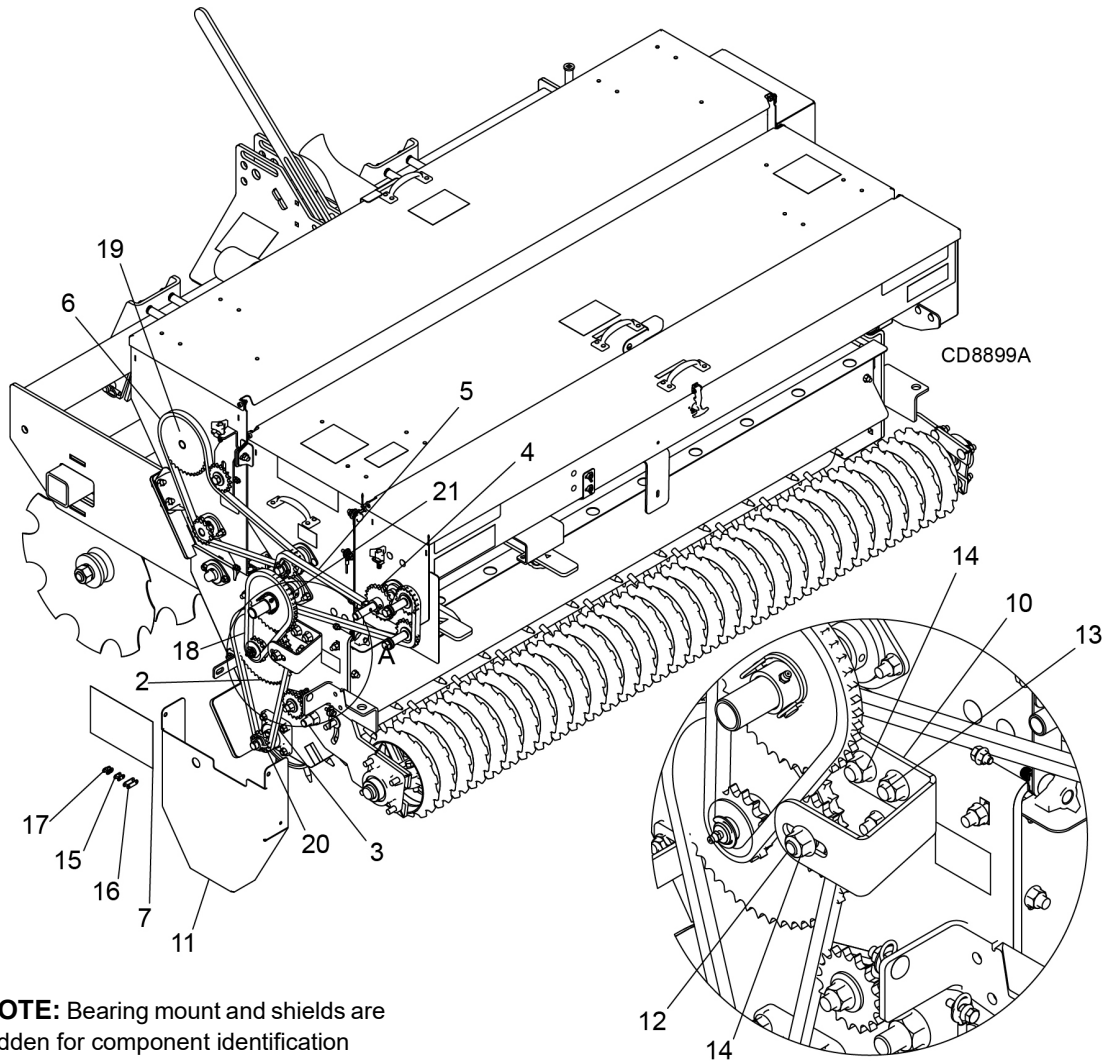

NOTE: Bearing mount and shields are hidden for component identification

REF	PART	QTY	DESCRIPTION
2	1036376	1	WA, sprocket RC40 15-50 1 in. bore
3	1036401	1	Chain, seeder main A2040 38 link
4	1036422	1	Sprocket, RC40 22th 3/4 bore
5	1036404	1	Chain, Legume box A2040 54 links
6	1036406	1	Chain, A2040 Native left 52 link
7	1036389	1	Dcl, super slow chain drive PSS
9	SU910	2	Bearing, needle .75 x 1.0 x .75 (Not shown; in item 2)
10	1037468RP	1	Channel, super slow kit idler
11	1038756RP	1	Shield, frame notched
12	3379	1	HHCS 1/2 NC x 1-1/2 GR5 ZP
13	2615	2	Bolt, crg 1/2 NC x 1-1/2 GR5 ZP
14	11900	3	Nut lock 1/2 NC flange
15	FA418	1	Link, RLR chain #40 SGL conn link
16	FA419	1	Link, RLR chain #2040 DBL pitch conn
17	1002959	1	Link, RLR chain #40 SGL offset pitch
18	1036403	1	Chain, Primary box A2040 29 links
19	1036383	1	Sprocket, RC40 40th 3/4 bore
20	1036412	1	Sprocket, RC40 12th 3/7 bore
21	1036407	1	WA, sprocket RC40 15-40 1-1/8 bore

PLATFORM ACCESSORY

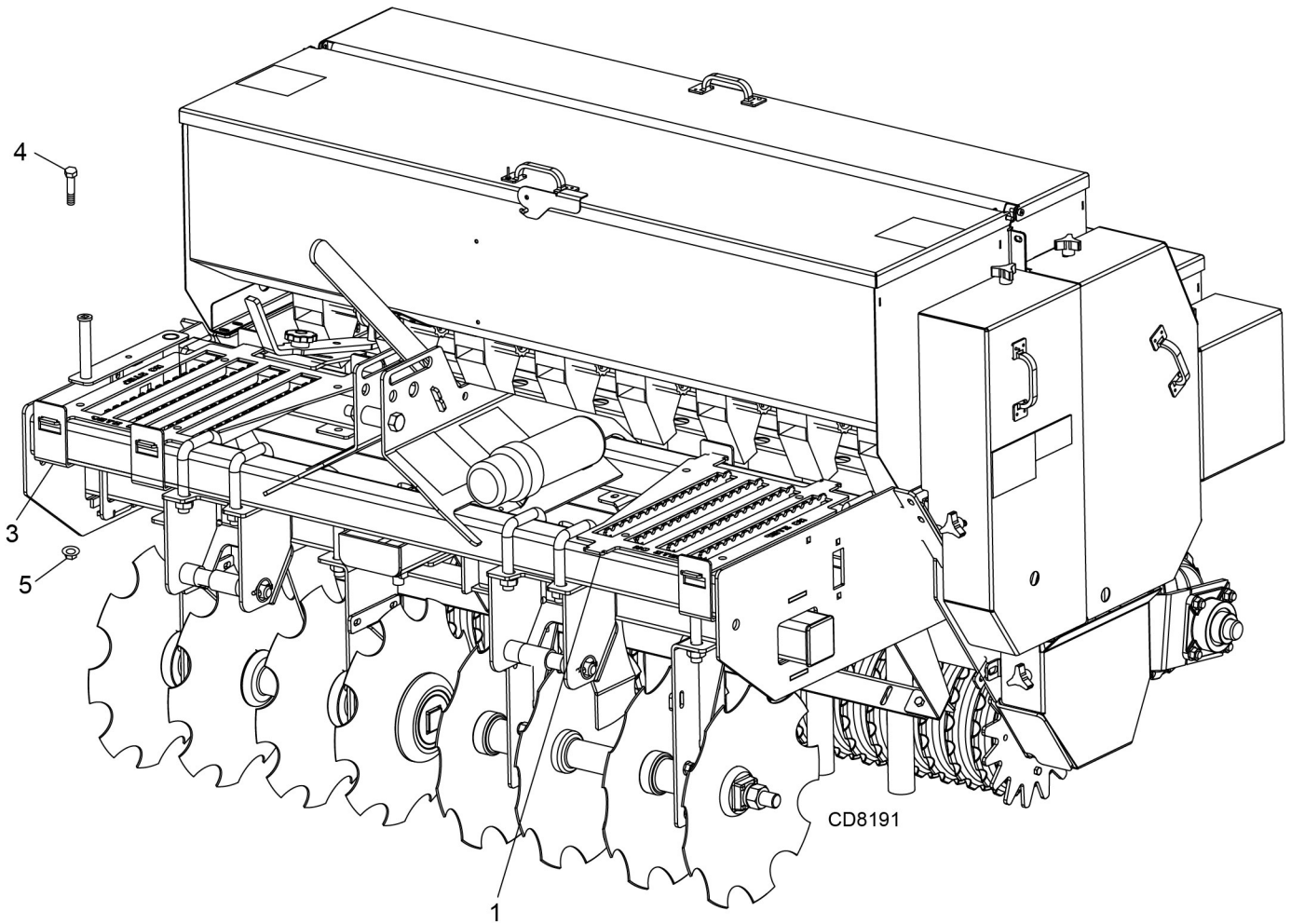

REF	PSS48	PSS60	PSS72	PSS84	QTY	DESCRIPTION
1	-----	1038757RP	1038757RP	1038757RP	2	Platform, seeder
3	-----	1038762RP	1038762RP	1038762RP	8	Clamp, platform
4	-----	10380*	10380*	10380*	8	1/2 NC x 4 HHCS, GR5
5	-----	11900*	11900*	11900*	8	1/2 NC flanged lock nut

HHCS - Hex Head Cap Screw

* Standard Hardware, Obtain Locally

604387 LIGHT KIT OPTION

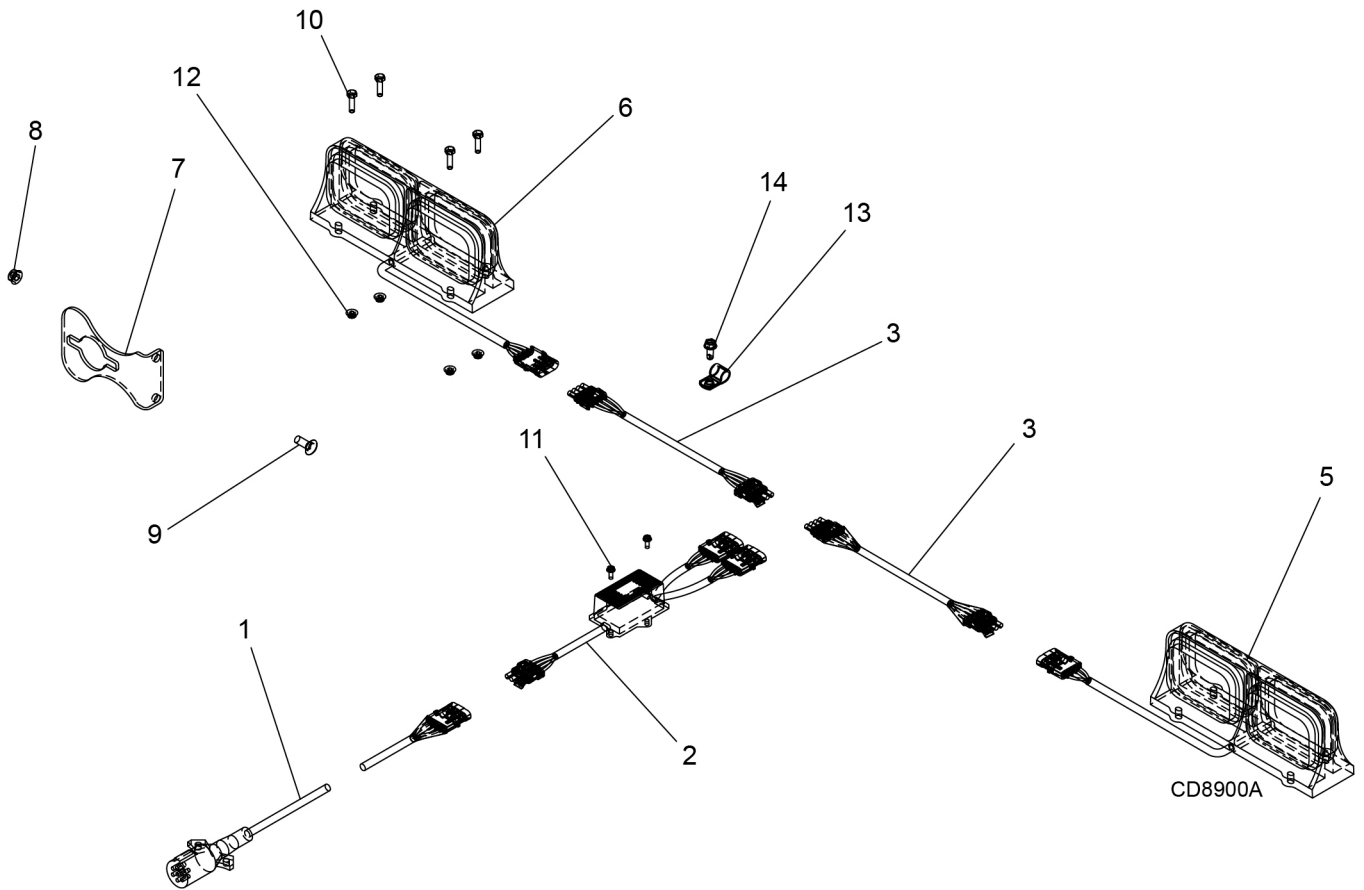

REF	PART	QTY	DESCRIPTION
1	599771	1	Main harness, 4 ft
2	1040277	1	AG enhancer module
3	599772	2	Rear harness, 6 ft RH
5	1040275	1	LED AG combo lamp LH
6	1040276	1	LED AG combo lamp RH
7	602513RP	1	Angle, plug holder, 7 pin
8	14350	1	Nut lock 3/8 NC flange
9	6697	1	Bolt crg 3/8 NC x GR5 ZP
10	10378	8	1/4 NC x 1 HHCS, GR5
11	73542	2	#10 NC x 1/2 self tap screw
12	W70065	8	1/4 NC whiz nut
13	35249	4	.50 dia p-clip
14	W30036	4	5/16 NC x 3/4 self tap screw

PSS48, PSS60, PSS72, PSS84 TOW KIT OPTION
(CONTINUED ON PAGE 62)

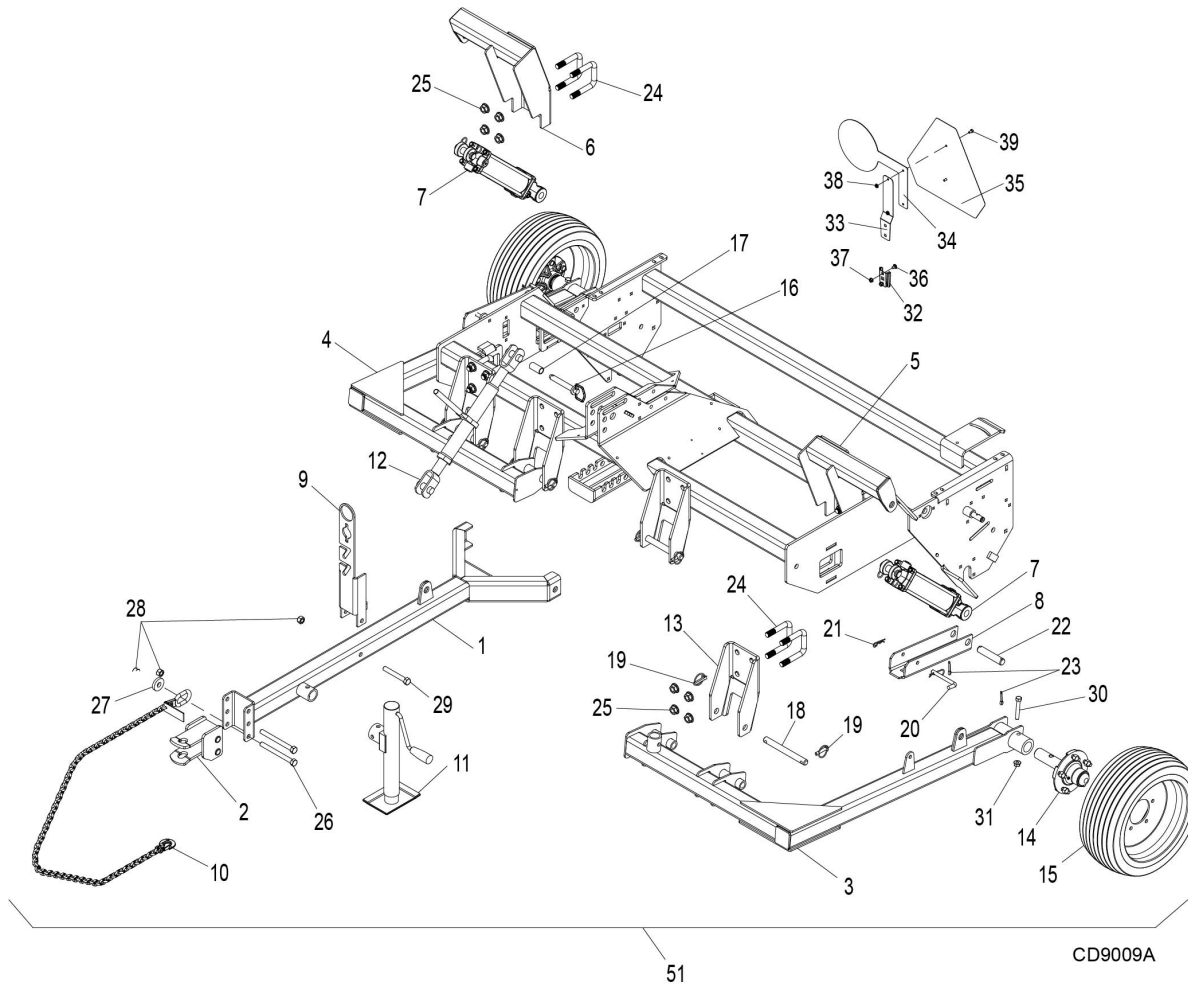

REF	GS1148	GS1160	GS1172	GS1184	QTY	DESCRIPTION
1	609306RP	609306RP	609306RP	609306RP	1	Tow tongue GS
2	609708	609708	609708	609708	1	Tow hitch
3	6110148RP	6110160RP	6110172RP	6110184RP	1	Tow carrier LH
4	6110248RP	6110260RP	6110272RP	6110284RP	1	Tow carrier RH
5	611103RP	611103RP	611103RP	611103RP	1	Hanger GS LH
6	611104RP	611104RP	611104RP	611104RP	1	Hanger GS RH
7	597269	597269	597269	597269	2	Cylinder, 3.0 x 1.25 x 10.0 NPT8
8	611699RP	611699RP	611699RP	611699RP	2	Transport lock
9	609707RP	609707RP	609707RP	609707RP	1	Hose holder
10	19407	19407	19407	19407	1	Safety chain, 10,000 lb
11	23790	23790	23790	23790	1	Swivel parking jack
12	20020705	20020705	20020705	20020705	1	Ratchet jack
13	1034669RP	1034669RP	1034669RP	1034669RP	2	Hitch mount seeder
14	1017050	1017050	1017050	1017050	2	Wheel, hub, 5 bolt
15	609309GRP	609309GRP	609309GRP	609309GRP	2	Wheel, 20.5 x 6.75 - 10 Gray
16	1025163	1025163	1025163	1025163	1	Hitch pin 3/4 x 4-1/4
17	1000654RP	1000654RP	1000654RP	1000654RP	1	Sleeve .78 x 1.00 x 2.00
18	HBL233	HBL233	HBL233	HBL233	2	Pin headless .875 x 6.94
19	27542	27542	27542	27542 *	4	7/16 x 11/32 klik pin
20	W100181	W100181	W100181	W100181	2	Pin bent .50 x 4.5 w/ clip
21	2688	2688	2688	2688 *	2	1/8 hair pin
22	8345	8345	8345	8345	2	Pin headless 1.00 x 4.08
23	1285	1285	1285	1285 *	4	1/4 x 1-1/2 cotter pin
24	1034668	1034668	1034668	1034668	8	U-bolt 3/4 x 3.81 x 4.31
25	W302207	W302207	W302207	W302207 *	16	Nut lock 3/4 NC - flange head
26	78193	78193	78193	78193 *	2	HHCS 5/8 NC x 6-1/2 GR5 YD

REF	GS1148	GS1160	GS1172	GS1184	QTY	DESCRIPTION
27	W8424	W8424	W8424	W8424	1	Washer 5/8 ID 2OD 3/8 thick ZP
28	6239	6239	6239	6239	*	3 Nut lock 5/8 NC
29	3097	3097	3097	3097	*	1 HHCS 5/8 NC x 4-1/2 GR5 ZP
30	14069	14069	14069	14069	*	2 HHCS 1/2 NC x 3-1/4
31	11900	11900	11900	11900	*	2 Nut lock 1/2 NC flange
32	62484	62484	62484	62484	1	Socket, SMV emblem
33	1004251	1004251	1004251	1004251	1	SMV Bracket
34	611525	611525	611525	611525	1	Bracket, SMV SIS
35	24611	24611	24611	24611	1	Sign (SMV), slow moving vehicle
36	62532	62532	62532	62532	*	2 Bolt, crg 5/16 NC x .50 GR5
37	W73163	W73163	W73163	W73163	*	2 Nut, whiz 5/16 NC flanged YD
38	W70065	W70065	W70065	W70065	*	2 Nut, hex flange 1/4 NC SRTD
39	5337	5337	5337	5337	*	2 HHCS 1/4 NC x 1/2 GR5

* Standard hardware, obtain locally

PSS48, PSS60, PSS72, PSS84 TOW KIT HOSE ROUTING (CONTINUED FROM PAGE 61)

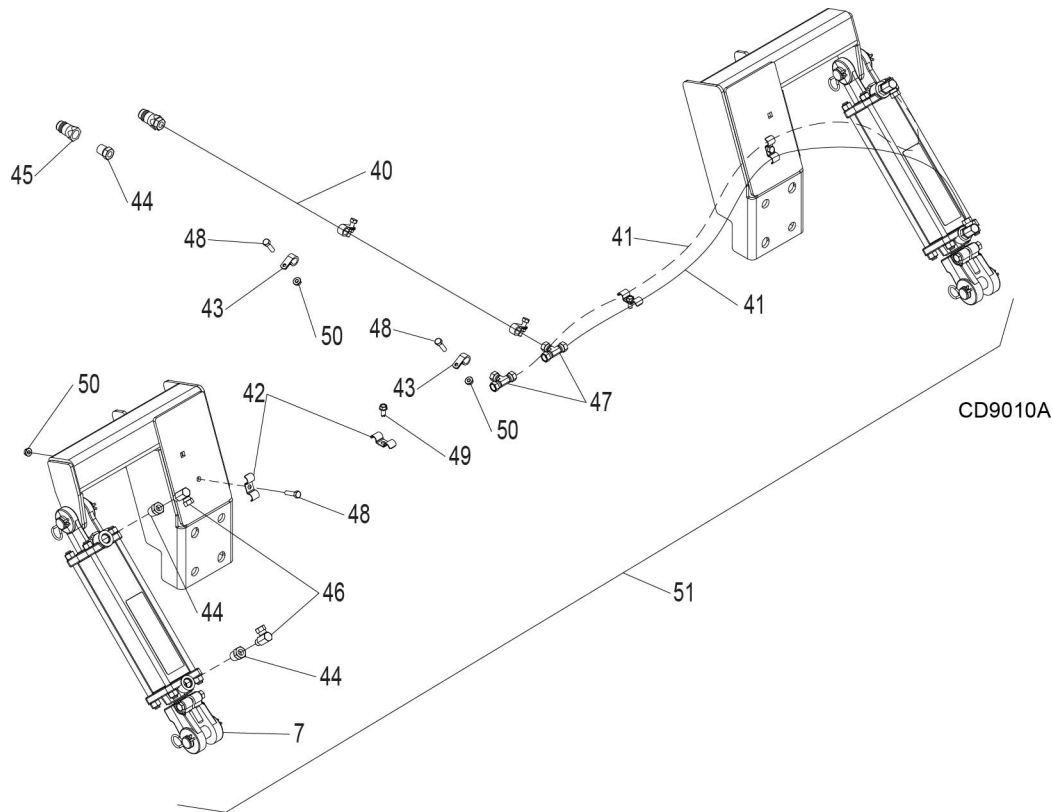

REF	GS1148	GS1160	GS1172	GS1184	QTY	DESCRIPTION
40	17628	17628	17628	17628	2	1/4 NPT x 108 hose
41	-	-	34221	34221	4	1/4 NPT x 65 hose (PSS72 / 84 only)
41	31237	31237	-	-	4	1/4 NPT x 47 hose (PSS48 / 60 only)
42	258	258	258	258	4	Feedline clamp
43	74058	74058	74058	74058	4	Clamp steel cushion
44	11893	11893	11893	11893	6	Adapter 1/4 NPTF 1/2 NPTM
45	66511	66511	66511	66511	2	Male quick coupler 1/2 NPT
46	8572	8572	8572	8572	4	1/4 x 1/4 90° elbow
47	31239	31239	31239	31239	2	1/4 swivel union tee
48	6250	6250	6250	6250	*	6 HHCS 5/16 NC x 1-1/4 GR5 ZP
49	W30036	W30036	W30036	W30036	*	2 5/16 NC x 3/4 self tap screw
50	W73163	W73163	W73163	W73163	*	6 Nut whiz 5/16 NC flange
51	60435248	60435260	60435272	60435284	1	Tow kit, complete

* Standard hardware, obtain locally

BOLT TORQUE CHART

Always tighten hardware to these values unless a different torque value or tightening procedure is listed for a specific application.

Fasteners must always be replaced with the same grade as specified in the manual parts list.

Always use the proper tool for tightening hardware: SAE for SAE hardware and Metric for metric hardware.

Make sure fastener threads are clean and you start thread engagement properly.

All torque values are given to specifications used on hardware defined by SAE J1701 MAR 99 & J1701M JUL 96.

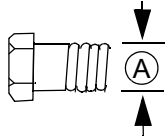

SAE SERIES TORQUE CHART



SAE Grade 2
(No Dashes)

SAE Bolt Head Identification



SAE Grade 5
(3 Radial Dashes)



SAE Grade 8
(6 Radial Dashes)

Ⓐ Diameter (Inches)	Wrench Size	MARKING ON HEAD					
		SAE 2		SAE 5		SAE 8	
		lbs-ft	N-m	lbs-ft	N-m	lbs-ft	N-m
1/4"	7/16"	6	8	10	13	14	18
5/16"	1/2"	12	17	19	26	27	37
3/8"	9/16"	23	31	35	47	49	67
7/16"	5/8"	36	48	55	75	78	106
1/2"	3/4"	55	75	85	115	120	163
9/16"	13/16"	78	106	121	164	171	232
5/8"	15/16"	110	149	170	230	240	325
3/4"	1-1/8"	192	261	297	403	420	569
7/8"	1-5/16"	306	416	474	642	669	907
1"	1-1/2"	467	634	722	979	1020	1383

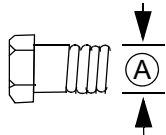

METRIC SERIES TORQUE CHART



Metric
Grade 8.8

Metric Bolt Head Identification



Metric
Grade 10.9

Ⓐ Diameter & Thread Pitch (Millimeters)	Wrench Size	Coarse Thread				Fine Thread				Ⓐ Diameter & Thread Pitch (Millimeters)
		Marking on Head				Marking on Head				
		Metric 8.8		Metric 10.9		Metric 8.8		Metric 10.9		
		N-m	lbs-ft	N-m	lbs-ft	N-m	lbs-ft	N-m	lbs-ft	
6 x 1.0	10 mm	8	6	11	8	8	6	11	8	6 x 1.0
8 x 1.25	13 mm	20	15	27	20	21	16	29	22	8 x 1.0
10 x 1.5	16 mm	39	29	54	40	41	30	57	42	10 x 1.25
12 x 1.75	18 mm	68	50	94	70	75	55	103	76	12 x 1.25
14 x 2.0	21 mm	109	80	151	111	118	87	163	120	14 x 1.5
16 x 2.0	24 mm	169	125	234	173	181	133	250	184	16 x 1.5
18 x 2.5	27 mm	234	172	323	239	263	194	363	268	18 x 1.5
20 x 2.5	30 mm	330	244	457	337	367	270	507	374	20 x 1.5
22 x 2.5	34 mm	451	332	623	460	495	365	684	505	22 x 1.5
24 x 3.0	36 mm	571	421	790	583	623	459	861	635	24 x 2.0
30 x 3.0	46 mm	1175	867	1626	1199	1258	928	1740	1283	30 x 2.0

Typical Washer Installations

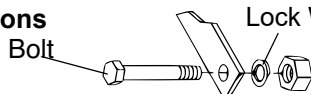

Lock Washer

Flat Washer

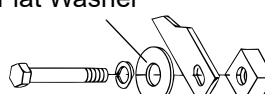

8/9/00

BOLT SIZE CHART

NOTE: Chart shows bolt thread sizes and corresponding head (wrench) sizes for standard SAE and metric bolts.

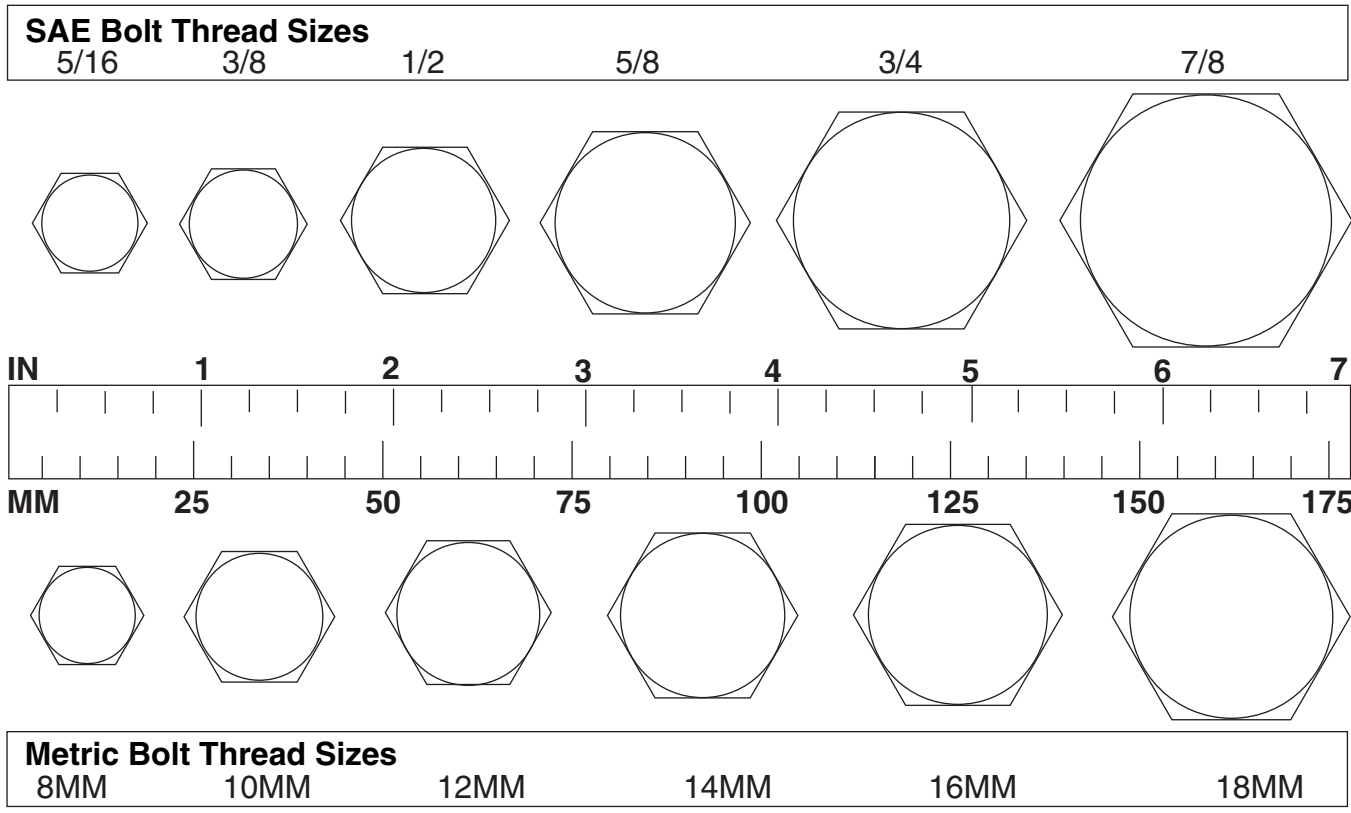

ABBREVIATIONS

AG Agriculture
 ASABE American Society of Agricultural & Biological Engineers (formerly ASAE)
 ASAE..... American Society of Agricultural Engineers
 ATF..... Automatic Transmission Fluid
 BSPP..... British Standard Pipe Parallel
 BSPTM..... British Standard Pipe Tapered Male
 CV Constant Velocity
 CCW..... Counter-Clockwise
 CW Clockwise
 F Female
 FT..... Full Thread
 GA Gauge
 GR (5, etc.)..... Grade (5, etc.)
 HHCS Hex Head Cap Screw
 HT..... Heat-Treated
 JIC..... Joint Industry Council 37° Degree Flare
 LH..... Left Hand
 LT Left
 m Meter
 mm Millimeter
 M Male

MPa Mega Pascal
 N Newton
 NC..... National Coarse
 NF National Fine
 NPSM National Pipe Straight Mechanical
 NPT..... National Pipe Tapered
 NPT SWF..... National Pipe Tapered Swivel Female
 ORBM O-Ring Boss - Male
 P Pitch
 PBY..... Power-Beyond
 psi Pounds per Square Inch
 PTO..... Power Take Off
 QD Quick Disconnect
 RH..... Right Hand
 ROPS..... Roll-Over Protective Structure
 RPM..... Revolutions Per Minute
 RT Right
 SAE..... Society of Automotive Engineers
 UNC Unified Coarse
 UNF Unified Fine
 UNS Unified Special

INDEX

ASSEMBLY

- Dealer Set-Up Instructions 31
- Optional Accessories 31
 - Cultipacker 32
 - Front Disc 31
 - Front Spike Roller 31
 - Legume Seed Box 32
 - Native Seed Box 31
 - Tow Kit 32

GENERAL

- Abbreviations 64
- Bolt Size Chart 64
- Bolt Torque Chart 63
- General Information 4
- Introduction 2
- Obtaining Replacement Manuals 2
- Specifications 4
- Table of Contents 3
- Warranty
 - Product - Inside Back Cover
 - Replacement Parts 66

OPERATION

- Adjust Front Disc Angle 16
- Adjust Front Roller Angle 16
- Attaching PSS to Tractor 13
- Calibration Formula 26
- Chain Drive Disconnect 12
- Front Disc 12
- Front Rollers 11
- Hitching PSS to Tractor 14
- Operation 11
- Pre-Operation Check List-(Owner's Responsibility) 27
- PSS Attitude Adjustment 15
- PSS Ground Tool Operation 11

- Rear Roller 12
- Seed Box/Types of Seeds 17
- Seeding Operation 17
 - Calibration Tray 25
 - Cultipacker 25
 - Filling the Seed Box 18
 - Legume Seed Cup 22
 - Primary Seed Cup Concave Lever Adjustment 22
 - Sample Seed Rate Chart 19
 - Seed Rate 21
 - Seed Rate Adjustment 21
- Stationary Calibration Procedure 25
 - Equipment 25
 - Procedure 25
- Tractor Stability 12
- Mobile Calibration Procedure 25
 - Equipment 25
 - Procedure 25
- Transportation 27

OWNER SERVICE

- Cleaning 30
 - After Each Use 30
 - Periodically or Before Extended Storage 30
- Lubrication Information 28

PARTS

- Index to Parts Lists 37

SAFETY

- Check Lists
 - Pre-Operation (Owner's Responsibility) 27
 - Pre-Delivery (Dealer's Responsibility) 36
 - Deliver (Dealer's Responsibility) 36
- Safety & Instructional Decals 8, 9, 10
- Safety Rules 5, 6, 7
- Safety Symbols Explained 2

WARRANTY

(Replacement Parts For All Models Except Zero-Turn Mowers)

Woods Equipment Company (“WOODS”) warrants this product to be free from defect in material and workmanship for a period of ninety (90) days from the date of delivery of the product to the original purchaser with the exception of V-belts, which will be free of defect in material and workmanship for a period of 12 months.

Under no circumstances will this Warranty apply in the event that the product, in the good faith opinion of WOODS, has been subjected to improper operation, improper maintenance, misuse, or an accident. This Warranty does not cover normal wear or tear, or normal maintenance items.

This Warranty is extended solely to the original purchaser of the product. Should the original purchaser sell or otherwise transfer this product to a third party, this Warranty does not transfer to the third party purchaser in any way. There are no third party beneficiaries of this Warranty.

WOODS’ obligation under this Warranty is limited to, at WOODS’ option, the repair or replacement, free of charge, of the product if WOODS, in its sole discretion, deems it to be defective or in noncompliance with this Warranty. **The product must be returned to WOODS with proof of purchase within thirty (30) days after such defect or noncompliance is discovered or should have been discovered, routed through the dealer and distributor from whom the purchase was made, transportation charges prepaid.** WOODS shall complete such repair or replacement within a reasonable time after WOODS receives the product. THERE ARE NO OTHER REMEDIES UNDER THIS WARRANTY. THE REMEDY OF REPAIR OR REPLACEMENT IS THE SOLE AND EXCLUSIVE REMEDY UNDER THIS WARRANTY.

THERE ARE NO WARRANTIES WHICH EXTEND BEYOND THE DESCRIPTION ON THE FACE OF THIS WARRANTY. WOODS MAKES NO OTHER WARRANTY, EXPRESS OR IMPLIED, AND WOODS SPECIFICALLY DISCLAIMS ANY IMPLIED WARRANTY OF MERCHANTABILITY AND/OR ANY IMPLIED WARRANTY OF FITNESS FOR A PARTICULAR PURPOSE.

WOODS shall not be liable for any incidental or consequential losses, damages or expenses, arising directly or indirectly from the product, whether such claim is based upon breach of contract, breach of warranty, negligence, strict liability in tort or any other legal theory. Without limiting the generality of the foregoing, Woods specifically disclaims any damages relating to (i) lost profits, business, revenues or goodwill; (ii) loss of crops; (iii) loss because of delay in harvesting; (iv) any expense or loss incurred for labor, supplies, substitute machinery or rental; or (v) any other type of damage to property or economic loss.

This Warranty is subject to any existing conditions of supply which may directly affect WOODS’ ability to obtain materials or manufacture replacement parts.

No agent, representative, dealer, distributor, service person, salesperson, or employee of any company, including without limitation, WOODS, its authorized dealers, distributors, and service centers, is authorized to alter, modify, or enlarge this Warranty.

Answers to any questions regarding warranty service and locations may be obtained by contacting:

ALITEC™
CENTRAL FABRICATORS®
GANNON®
WAIN-ROY®
WOODS®

WOODS®

WOODS® | A Blount International Brand
2606 South Illinois Route 2
Post Office Box 1000
Oregon, Illinois 61061 USA
800-319-6637 tel
800-399-6637 fax
woodsequipment.com

WARRANTY

All Models Except Zero-Turn Mowers

Please Enter Information Below and Save for Future Reference.

Date Purchased: _____ From (Dealer): _____

Model Number: _____ Serial Number: _____

Woods Equipment Company ("WOODS") warrants this product to be free from defect in material and workmanship. Except as otherwise set forth below, the duration of this Warranty shall be for TWELVE (12) MONTHS COMMENCING ON THE DATE OF DELIVERY OF THE PRODUCT TO THE ORIGINAL PURCHASER.

All current model backhoes, loaders and mounts (except 3-pt. SAF-T-LOK® mounts) are warranted for two (2) years from the date of delivery to the original purchaser. The limited warranty covers any defects in the material and/or workmanship. Following the proper, recommended installation by an authorized Woods Dealer and normal use of a Woods mounting and backhoe or loader, if a tractor incurs damage resulting from the attachment, Woods will cover the existing tractor warranty in the event the manufacturer voids its tractor warranty because of the attachment. Warranty does not cover any misuse or abusive conditions that could cause premature wear or damage to attachment or tractor.

The warranty periods for specific parts or conditions are listed below:

Part or Condition Warranted	Model Number	Duration (from date of delivery to the original purchaser)
	All units invoiced after 4/30/2012	
Gearbox components	BB48.30, BB60.30, BB72.30, BB84.40, BB60.50, BB72.50, BB60.60, BB72.60, BB84.60, BB84.50, DS8.30, DS10.40, DS8.50, DSO8.50, DS10.50, DSO10.50, DBH5.31, DBH6.31	6 years
	BW12, BW10.50, BW10.50Q, BW15.50, BW15.50Q, BW10.60, BW10.60Q, BW13.70, BW13.70Q, BW13.70QREV, BW15.60, BW15.60Q, BW10.70, BW10.70Q, BW15.70, BW15.70Q, BW20.50, BW20.50Q, BW20.60, BW20.60Q, BW20.70, BW20.70Q, BW20.51, BW20.51Q, BW20.61, BW20.61Q, BW20.71, BW20.71Q, BW13.71, BW13.71Q, BW13.71QREV	
	BW240X, BW240XHD, BW1620X, BW2400X	
	RD990X, PRD6000, PRD7200, PRD8400, S15CD, S20CD, S22CD, S25CD, S27CD, S30CD, TC/R74, TC/R68, TC/R60, TBW144, TBW180, TBW204, TSG50, S12ED, S15ED, S18ED, S20ED	
	FM60.20, FM72.20, TBW150C, RT/R42.30, RT/R48.30, RT/R60.40, RT/R72.40, RC3.5, RC4, RC5, RC6	3 years (1 year if used in rental or commercial applications)
Blade spindles	RD990X, PRD6000, PRD7200, PRD8400, TBW144, TBW180, TBW204	3 years

Under no circumstances will this Warranty apply in the event that the product, in the good faith opinion of WOODS, has been subjected to improper operation, improper maintenance, misuse, or an accident. This Warranty does not apply in the event that the product has been materially modified or repaired by someone other than WOODS, a WOODS authorized dealer or distributor, and/or a WOODS authorized service center. This Warranty does not cover normal wear or tear, or normal maintenance items. This Warranty also does not cover repairs made with parts other than those obtainable through WOODS.

This Warranty is extended solely to the original purchaser of the product. Should the original purchaser sell or otherwise transfer this product to a third party, this Warranty does not transfer to the third party purchaser in any way. There are no third party beneficiaries of this Warranty.

WOODS makes no warranty, express or implied, with respect to engines, batteries, tires or other parts or accessories not manufactured by WOODS. Warranties for these items, if any, are provided separately by their respective manufacturers.

WOODS' obligation under this Warranty is limited to, at WOODS' option, the repair or replacement, free of charge, of the product if WOODS, in its sole discretion, deems it to be defective or in noncompliance with this Warranty. **The product must be returned to WOODS with proof of purchase within thirty (30) days after such defect or noncompliance is discovered or should have been discovered, routed through the dealer and distributor from whom the purchase was made, transportation charges prepaid.** WOODS shall complete such repair or replacement within a reasonable time after WOODS receives the product. **THERE ARE NO OTHER REMEDIES UNDER THIS WARRANTY. THE REMEDY OF REPAIR OR REPLACEMENT IS THE SOLE AND EXCLUSIVE REMEDY UNDER THIS WARRANTY.**

THERE ARE NO WARRANTIES WHICH EXTEND BEYOND THE DESCRIPTION ON THE FACE OF THIS WARRANTY. WOODS MAKES NO OTHER WARRANTY, EXPRESS OR IMPLIED, AND WOODS SPECIFICALLY DISCLAIMS ANY IMPLIED WARRANTY OF MERCHANTABILITY AND/OR ANY IMPLIED WARRANTY OF FITNESS FOR A PARTICULAR PURPOSE.

WOODS shall not be liable for any incidental or consequential losses, damages or expenses, arising directly or indirectly from the product, whether such claim is based upon breach of contract, breach of warranty, negligence, strict liability in tort or any other legal theory. Without limiting the generality of the foregoing, Woods specifically disclaims any damages relating to (i) lost profits, business, revenues or goodwill; (ii) loss of crops; (iii) loss because of delay in harvesting; (iv) any expense or loss incurred for labor, supplies, substitute machinery or rental; or (v) any other type of damage to property or economic loss.

This Warranty is subject to any existing conditions of supply which may directly affect WOODS' ability to obtain materials or manufacture replacement parts.

No agent, representative, dealer, distributor, serviceperson, salesperson, or employee of any company, including without limitation, WOODS, its authorized dealers, distributors, and service centers, is authorized to alter, modify, or enlarge this Warranty. Answers to any questions regarding warranty service and locations may be obtained by contacting:

WOODS® | A Blount International Brand

2606 South Illinois Route 2
Post Office Box 1000
Oregon, Illinois 61061 USA

800-319-6637 tel
800-399-6637 fax
woodsequipment.com



ALITEC™
CENTRAL FABRICATORS®
GANNON®
WAIN-ROY®
WOODS®

PART NO.
MAN0988

WOODS® | A Blount International Brand

2606 South Illinois Route 2
Post Office Box 1000
Oregon, Illinois 61061 USA

800-319-6637 tel
800-399-6637 fax
woodsequipment.com

WOODS®

© 2020 Woods Equipment Company. All rights reserved. Woods® and the Woods logo are trademarks of Woods Equipment Company. All other trademarks, trade names, or service marks not owned by Woods Equipment Company that appear in this manual are the property of their respective companies or mark holders. Specifications subject to change without notice.