

# PALLET FORK

PF1242S2

PFW2242S2

PFW4442S2

PFW4448S2

PF4448S2

PFW6648S2

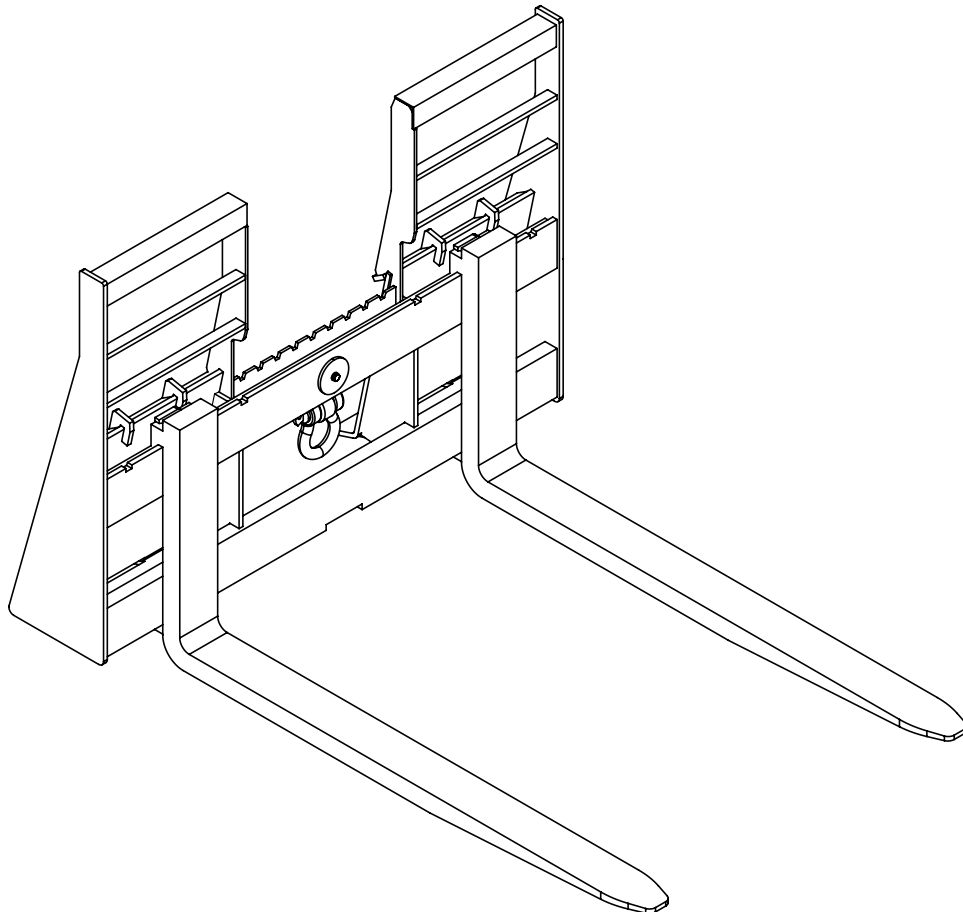

**MAN1354**  
(Rev 04/29/2026)

**WOODS**<sup>®</sup>

OPERATOR'S MANUAL

## TO THE DEALER:

Assembly and proper installation of this product is the responsibility of the Woods® dealer. Read manual instructions and safety rules. Make sure all items on the Dealer's Pre-Delivery and Delivery Checklists in the Operator's Manual are completed before releasing equipment to the owner.

**The dealer must complete the online Product Registration form at the Woods Dealer Website** which certifies that all Dealer Checklist items have been completed. Dealers can register all Woods product at [dealer.WoodsEquipment.com](http://dealer.WoodsEquipment.com) under Product Registration.

**Failure to register the product does not diminish customer's warranty rights.**

## TO THE OWNER:

Read this manual before operating your Woods equipment. The information presented will prepare you to do a better and safer job. Keep this manual handy for ready reference. Require all operators to read this manual carefully and become acquainted with all adjustment and operating procedures before attempting to operate. Replacement manuals can be obtained from your dealer. To obtain complete warranty details, visit [WoodsEquipment.com/warranty](http://WoodsEquipment.com/warranty). You may also request a hard copy by calling 1-800-319-6637 or mail your request to: Woods Equipment Company, Attn: Warranty Dept. 2606 South Illinois Route 2, Oregon, IL 61061. To locate your nearest dealer, check the Dealer Locator at [www.WoodsEquipment.com](http://www.WoodsEquipment.com), or in the United States and Canada call 1-800-319-6637.

The equipment you have purchased has been carefully engineered and manufactured to provide dependable and satisfactory use. Like all mechanical products, it will require cleaning and upkeep. Lubricate the unit as specified. Observe all safety information in this manual and safety decals on the equipment.

For service, your authorized Woods dealer has trained mechanics, genuine Woods service parts, and the necessary tools and equipment to handle all your needs.

Use only genuine Woods service parts. Substitute parts will void the warranty and may not meet standards required for safe and satisfactory operation. Record the model number and serial number of your equipment in the spaces provided:

**Model:** \_\_\_\_\_ **Date of Purchase:** \_\_\_\_\_

**Serial Number:** (see Safety Decal section for location) \_\_\_\_\_

Provide this information to your dealer to obtain correct repair parts.

Throughout this manual, the term **NOTICE** is used to indicate that failure to observe can cause damage to equipment. The terms **CAUTION**, **WARNING**, and **DANGER** are used in conjunction with the Safety-Alert Symbol (a triangle with an exclamation mark) to indicate the degree of hazard for items of personal safety.



This is the safety alert symbol. It is used to alert you to potential physical injury hazards. Obey all safety messages that follow this symbol to avoid possible injury or death.



Indicates a hazardous situation that, if not avoided, will result in death or serious injury.



Indicates a hazardous situation that, if not avoided, could result in death or serious injury.



Indicates a hazardous situation that, if not avoided, could result in minor or moderate injury.

**IMPORTANT  
or NOTICE**

Is used to address practices not related to physical injury.

**NOTE**

Indicates helpful information.

## 2 Introduction

MAN1354  
(04/29/2026)

# TABLE OF CONTENTS

<b>INTRODUCTION</b> . . . . .	<b>2</b>
SPECIFICATIONS . . . . .	4
GENERAL INFORMATION . . . . .	4
<b>SAFETY</b> . . . . .	<b>5</b>
SAFETY RULES . . . . .	5
TRAINING . . . . .	5
PREPARATION . . . . .	5
OPERATION . . . . .	5
MAINTENANCE . . . . .	6
STORAGE . . . . .	7
SAFETY & INSTRUCTIONAL DECALS . . . . .	8
<b>OPERATION</b> . . . . .	<b>10</b>
OPERATION . . . . .	10
ATTACHING PALLET FORK TO LOADER . . . . .	10
OPERATING LOADER . . . . .	11
ADJUSTING FORK SPACING . . . . .	11
LOCK LEVER . . . . .	12
REMOVING FROM LOADER . . . . .	12
STORAGE . . . . .	12
PRE-OPERATION CHECKLIST . . . . .	12
<b>OWNER SERVICE</b> . . . . .	<b>13</b>
OWNER SERVICE . . . . .	13
DAILY SERVICE . . . . .	13
FORK REMOVAL . . . . .	13
FORK INSTALLATION . . . . .	14
CLEANING . . . . .	14
<b>ASSEMBLY</b> . . . . .	<b>15</b>
ASSEMBLY . . . . .	15
DEALER SET-UP INSTRUCTIONS . . . . .	15
<b>DEALER CHECKLISTS</b> . . . . .	<b>16</b>
<b>PARTS</b> . . . . .	<b>17</b>
<b>APPENDIX</b> . . . . .	<b>19</b>
BOLT TORQUE CHART . . . . .	19
BOLT SIZE CHART & ABBREVIATIONS . . . . .	20
<b>INDEX</b> . . . . .	<b>21</b>



**¡LEA EL INSTRUCTIVO!**  
 Si no lee Ingles, pida ayuda a alguien que si lo lee para que le traduzca las medidas de seguridad.



**This Operator’s Manual should be regarded as part of the machine. Suppliers of both new and second-hand machines must make sure that this manual is provided with the machine.**

# SPECIFICATIONS

## MODELS

SPECIFICATION	PF1242S2	PFW2242S2	PFW4442S2	PFW4448S2	PF4448S2	PFW6648S2
Weight (lbs)	232	295	383	400	410	556
Fork Spread	Maximum width 45 inches (six inch increments)	Maximum width 46.75 inches (six inch increments)				
Brick Guard	Yes					
Double Hook Lock Down	Yes					
Maximum Carry Load (in lbs) at 19.7" load center of forks	1200	2200	4400	4400	4400	6600
Fork Cross Section	1.0 x 3.0	1.2 x 3.2	1.4 x 3.9	1.4 x 3.9	1.4 x 3.9	1.8 x 3.9

## GENERAL INFORMATION

### WARNING

- Some illustrations in this manual show the Pallet Fork with the lock plate removed to provide a better view. The Pallet Fork should never be operated with the lock plate removed.

The purpose of this manual is to assist you in operating and maintaining your Pallet Fork. Read it carefully. It furnishes information and instructions that will help you achieve years of dependable performance. These instructions have been compiled from extensive field experience and engineering data. Some information may be general in nature due to unknown and varying

operating conditions. However, through experience and these instructions, you should be able to develop procedures suitable to your particular situation.

The illustrations and data used in this manual were current at the time of printing, but due to possible inline production changes, your machine may vary slightly in detail. We reserve the right to redesign and change the machines as may be necessary without notification.

Throughout this manual, references are made to right and left directions. These are determined by standing behind the equipment facing the direction of forward travel.

# SAFETY RULES



**ATTENTION! BECOME ALERT! YOUR SAFETY IS INVOLVED!**



Safety is a primary concern in the design and manufacture of our products. Unfortunately, our efforts to provide safe equipment can be wiped out by an operator's single careless act.

In addition to the design and configuration of equipment, hazard control and accident prevention are dependent upon the awareness, concern, judgement, and proper training of personnel involved in the operation, transport, maintenance, and storage of equipment.

It has been said, "The best safety device is an informed, careful operator." We ask you to be that kind of operator.

## TRAINING

- Safety instructions are important! Read all attachment and power unit manuals; follow all safety rules and safety decal information. (Replacement manuals and safety decals are available from your dealer. To locate your nearest dealer, check the Dealer Locator at [www.WoodsEquipment.com](http://www.WoodsEquipment.com), or in the United States and Canada call 1-800-319-6637.) Failure to follow instructions or safety rules can result in serious injury or death.
- If you do not understand any part of this manual and need assistance, see your dealer.
- Know your controls and how to stop engine and attachment quickly in an emergency.
- Operators must be instructed in and be capable of the safe operation of the equipment, its attachments, and all controls. Do not allow anyone to operate this equipment without proper instructions.
- Never allow children or untrained persons to operate equipment.

## PREPARATION

- Check that all hardware is properly installed. Always tighten to torque chart specifications unless instructed otherwise in this manual.
- Counterweight ballast may be required for machine stability. Check your power unit manual or contact your dealer.
- Power unit must be equipped with ROPS and seat belt/operator restraint. Keep seat belt/operator restraint securely fastened/engaged. Falling off power unit can result in death from being run over or crushed. Keep ROPS systems in place at all times.

- Air in hydraulic systems can cause erratic operation and allows loads or equipment components to drop unexpectedly. When connecting equipment or hoses or performing any hydraulic maintenance, purge any air in hydraulic system by operating all hydraulic functions several times. Do this before putting into service or allowing anyone to approach the equipment.
- Be sure attachment is properly secured, adjusted, and in good operating condition. Coupler lockpins must be fully extended and properly engaged into attachment retaining slots.
- Make sure shields and guards are properly installed and in good condition. Replace if damaged.
- Always wear relatively tight and belted clothing to avoid entanglement in moving parts. Wear sturdy, rough-soled work shoes and protective equipment for eyes, hair, hands, hearing, and head; and respirator or filter mask where appropriate.
- Make sure all safety decals are installed. Replace if damaged. (See Safety Decals section for location.)

## OPERATION

- Improper operation can cause the machine to tip or roll over and cause injury or death.
  - Keep power unit lift arms and attachment as low as possible.
  - Do not travel or turn with power unit lift arms and attachment raised.
  - Turn only on level ground.
  - Go up and down slopes, not across them.
  - Keep the heavy end of the machine uphill.
  - Do not overload the machine.
- Never use attachment to carry loads that exceed the rated operating capacity or other specifications of the power unit. Check your power unit manual or see your dealer for rated operating capacity. Exceeding this capacity can cause machine to tip, roll over, or present other hazards that can cause injury or death.
- Do not allow children, bystanders or animals in the area when operating, attaching, removing, assembling, or servicing equipment.
- Do not exceed loader rated operating capacity with load centered 19.7" (500 mm) from the lift mast.

# SAFETY RULES



**ATTENTION! BECOME ALERT! YOUR SAFETY IS INVOLVED!**



- Do not put Pallet Fork into service without forks properly engaged on frame rails and fork lockplate secured in place. Fork locks must be engaged into fork lock notches. Replace if damaged.
- Consult local utilities before digging. Know location and depth of all underground cables, pipelines, and other hazards in working area and avoid contact.
- Contact with high voltage, overhead power lines, underground cables, gas lines, and other hazards can cause serious injury or death from electrocution, explosion, or fire.
- Keep bystanders away from equipment.
- Do not operate or transport equipment while under the influence of alcohol or drugs.
- Operate only in daylight or good artificial light.
- Keep hands, feet, hair, and clothing away from equipment while engine is running. Stay clear of all moving parts.
- Always comply with all state and local lighting and marking requirements.
- Do not allow riders. Do not lift or carry anybody on the power unit or attachments.
- Always sit in power unit seat when operating controls or starting engine. Securely fasten seat belt/operator restraint, place transmission in park or neutral, engage brake and ensure all other controls are disengaged before starting power unit engine.
- Look down and to the rear and make sure area is clear before operating in reverse.
- Use extreme care when working close to fences, ditches, other obstructions, or on hillsides.
- Use caution when handling loose or shiftable loads.
- Do not operate or transport on steep slopes.
- Allow for forklift length when making turns.
- Stop the forks gradually when lowering or lifting.
- Do not stop, start, or change directions suddenly on slopes.
- Use extreme care and reduce ground speed on slopes and rough terrain.
- Watch for hidden hazards on the terrain during operation.
- Stop power unit and implement immediately upon striking an obstruction. Dismount power unit, using proper procedure. Inspect and repair any damage before resuming operation.
- Leak down or failure of mechanical or hydraulic system can cause equipment to drop.
- **AVOID INJURY OR DEATH FROM FALLING OBJECTS:**
  - Do not carry shiftable items. Hay bales, logs, fence posts, stones, and other objects can roll or fall from a raised attachment and crush operator or children, bystanders or animals.
  - This unit is not equipped with any method to prevent objects such as round bales, posts, or logs from rolling back onto operator.
  - Do not handle round hay bales.
  - Carry loads low and drive slowly.
  - Do not carry large objects that can fall out of attachment into operator zone.
  - Never lift load higher than necessary to clear the ground when moving.
- Before leaving operator's seat, lower lift arms and put attachment on the ground. Engage brake, stop engine, remove key, and remove seat belt.

## MAINTENANCE

- **NEVER GO UNDERNEATH EQUIPMENT.** Never place any part of the body underneath equipment or between moveable parts even when the engine has been turned off. Hydraulic system leak-down, hydraulic system failures, mechanical failures, or movement of control levers can cause equipment to drop or rotate unexpectedly and cause severe injury or death.
  - Service work does not require going underneath.
  - Read Operator's Manual for service instructions or have service performed by a qualified dealer.
- Before performing service work that requires repair or replacement of parts, remove attachment from power unit. Hydraulic system failures, mechanical failures, or movement of control levers can cause equipment to drop or rotate unexpectedly and cause severe injury or death.
- Do not modify or alter or permit anyone else to modify or alter the equipment or any of its components in any way.

# SAFETY RULES



**ATTENTION! BECOME ALERT! YOUR SAFETY IS INVOLVED!**



- Always wear relatively tight and belted clothing to avoid getting caught in moving parts. Wear sturdy, rough-soled work shoes and protective equipment for eyes, hair, hands, hearing, and head; and respirator or filter mask where appropriate.
- Your dealer can supply original equipment hydraulic accessories and repair parts. Substitute parts may not meet original equipment specifications and may be dangerous.
- Be sure attachment is properly secured, adjusted, and in good operating condition. Coupler lockpins must be fully extended and properly engaged into attachment retaining slots.
- Never perform service or maintenance with engine running.
- Do not allow children, bystanders or animals in the area when operating, attaching, removing, assembling, or servicing equipment.
- Keep all persons away from operator control area while performing adjustments, service, or maintenance.
- Tighten all bolts, nuts, and screws to torque chart specifications. Check that all cotter pins are installed securely to ensure equipment is in a safe condition before putting unit into service.
- Make sure all safety decals are installed. Replace if damaged. (See Safety Decals section for location.)
- Leak down or failure of mechanical or hydraulic system can cause equipment to drop.

## STORAGE

- Block equipment securely for storage.
- Follow manual instructions for storage.
- Keep children, bystanders, and animals away from the equipment and the storage area
- Store on level, solid ground.

# SAFETY & INSTRUCTIONAL DECALS



**ATTENTION! BECOME ALERT! YOUR SAFETY IS INVOLVED!**



**Replace Immediately If Damaged!**

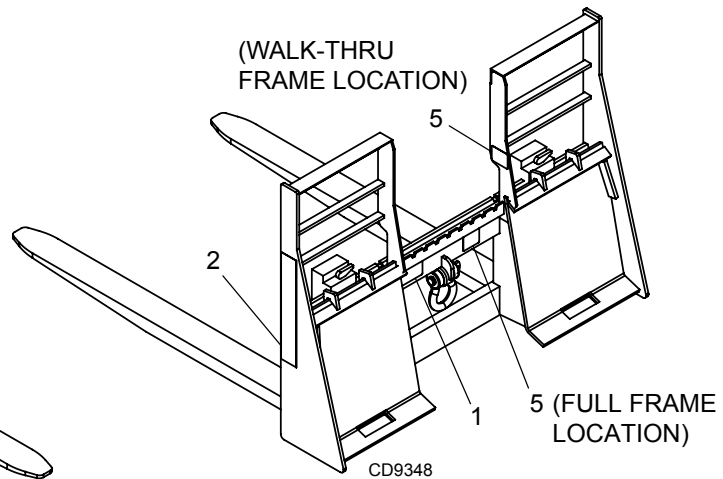
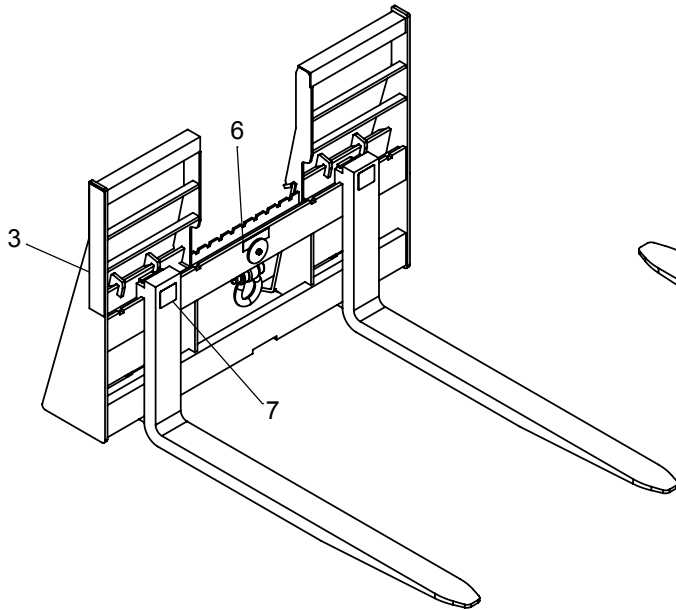
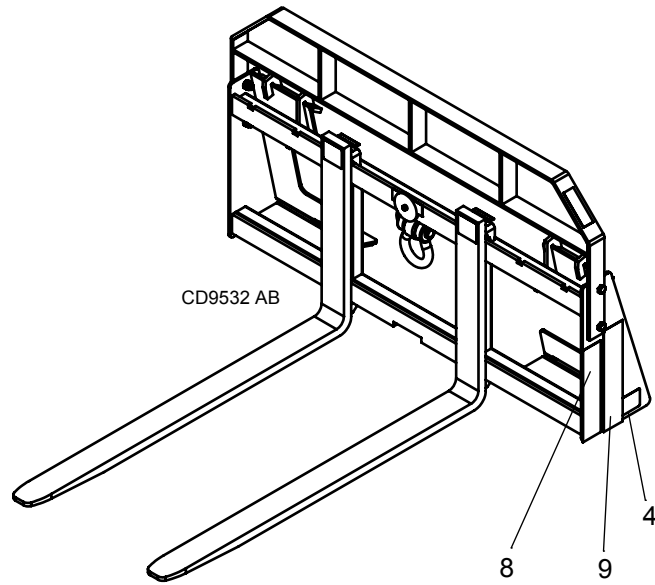
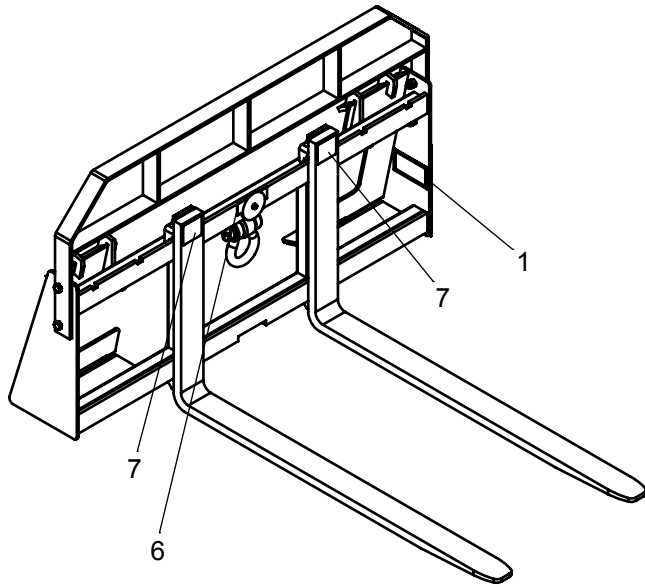

## BE CAREFUL!

Keep safety decals clean and visible.

Use a clean, damp cloth to clean safety decals.

Avoid spraying too close to decals when using a pressure washer; high-pressure water can enter through very small scratches or under edges of decals causing them to peel or come off.

Replacement safety decals can be ordered free from your Woods dealer. To locate your nearest dealer, check the Dealer Locator at [www.WoodsEquipment.com](http://www.WoodsEquipment.com), or in the United States and Canada call 1-800-319-6637.

## 1 - SERIAL NUMBER PLATE



# SAFETY & INSTRUCTIONAL DECALS



**ATTENTION! BECOME ALERT! YOUR SAFETY IS INVOLVED!**



**Replace Immediately If Damaged!**

2 - PN 1022032

**⚠ DANGER**

**TO AVOID SERIOUS INJURY OR DEATH,**

- Read Skid Steer Manual before operating.
- Before leaving operator's seat: follow Skid Steer Manual instructions, lower lift arms and attachment to ground, stop engine, remove key, engage brake, and remove seat belt/operator restraint.
- Do not exceed skid steer rated operating capacity with the load centered 19.7" (500mm) from the lift mast.



**FALLING OFF WILL RESULT IN BEING RUN OVER**

- Skid steer must have ROPS and seat belt/operator restraint. Keep seat belt/operator restraint securely fastened.
- Never allow riders.

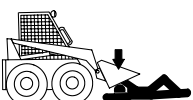

**RAISED EQUIPMENT CAN DROP AND CRUSH**

- Never go under raised equipment or raised skid steer lift arms. They can drop from hydraulic or mechanical failure, or moving control levers.
- Service work does not require going under equipment. Read manual instructions.

**FALLING OFF OR GOING UNDER MACHINE WILL RESULT IN SERIOUS INJURY OR DEATH.**

1022032 AB

3 - PN 1002991

**⚠ DANGER**

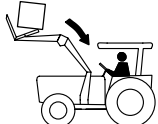

**FALLING LOAD HAZARD**

**TO AVOID SERIOUS INJURY OR DEATH,**

- Do not handle round bales or other loads that might shift, slide, or roll off.
- Do not use for digging rocks or lifting concrete slabs.
- Load must be carried equally on both forks.
- Lift and carry only one item at a time.
- Handle raised load with caution.
- Carry load low.

Failure to follow these instructions will lead to serious injury or death.

**⚠ WARNING**

**TO AVOID SERIOUS INJURY OR DEATH,**

- Read and understand the Loader Operator's Manual before operating. (Woods manuals are available from dealer or call 1-800-319-6637.)
- Keep children, bystanders and animals away from the equipment and storage area.
- Do not allow children or untrained persons to operate equipment.
- Never allow riders.
- Lower attachment to ground, stop engine, set park brake and remove key before leaving power unit seat.

Failure to follow these instructions can lead to serious injury or death.

**⚠ WARNING**

**CRUSHING HAZARD**

To properly store pallet fork:

- Block rear of pallet fork to prevent tipping rearward.
- Adjust forks as wide as possible.

Failure to follow these instructions can lead to serious injury or death.

1002991-AB

4 - PN 657173

**⚠ WARNING**

**MAXIMUM CARRY LOAD:**

**1200 lbs.**

at 19.7" load center of forks

657173

5 - PN 1045906

**⚠ WARNING**

**MAXIMUM CARRY LOAD:**

**2200 lbs.**

at 19.7" load center of forks

1045906

OR 5 - PN 1045907

**⚠ WARNING**

**MAXIMUM CARRY LOAD:**

**4400 lbs.**

at 19.7" load center of forks

1045907

OR 5 - PN 1045908

**⚠ WARNING**

**MAXIMUM CARRY LOAD:**

**6600 lbs.**

at 19.7" load center of forks

1045908

6 - PN 54809

**⚠ WARNING**

**FORK LOCKPLATE MISSING**

Do not operate. Forks can come off. Replace lockplate.

54809-AC

7 - PN 606323

**⚠ CAUTION**

**Heavy object.**  
Can cause muscle strain or back injury.

Use lifting aids and proper lifting techniques when moving.

606323

8 - PN 654212

**⚠ WARNING**

**TO AVOID SERIOUS INJURY OR DEATH,**

- Read and understand the Loader Operator's Manual before operating. (Woods manuals are available from dealer or call 1-800-319-6637.)
- Keep children, bystanders and animals away from the equipment and storage area.
- Do not allow children or untrained persons to operate equipment.
- Never allow riders.
- Lower attachment to ground, stop engine, set park brake and remove key before leaving power unit seat.
- Do not exceed loader rated operating capacity with the load centered 19.7" (500 mm) from the lift mast.

**CRUSHING HAZARD**

To properly store pallet fork:

- Block rear of pallet fork to prevent tipping rearward.
- Adjust forks as wide as possible.
- Keep children, bystanders, and animals away from equipment and the storage area.

Failure to follow these instructions can lead to serious injury or death.

654212 AA

9 - PN 654220

**⚠ DANGER**

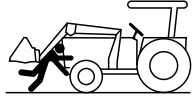

**RAISED EQUIPMENT CAN DROP AND CRUSH**

- Never go under raised equipment or raised loader lift arms. They can drop from hydraulic or mechanical failure, or moving control levers.
- Service work does not require going under equipment. Read manual instructions.



**FALLING LOAD HAZARD**

**TO AVOID SERIOUS INJURY OR DEATH,**

- Do not handle round bales or other loads that might shift, slide, or roll off.
- Do not use for digging rocks or lifting concrete slabs.
- Load must be carried equally on both forks.
- Lift and carry only one item at a time.
- Handle raised load with caution.
- Carry load low.

FAILURE TO FOLLOW THESE INSTRUCTIONS WILL LEAD TO SERIOUS INJURY OR DEATH.

654220 AA

# OPERATION

The operator is responsible for the safe operation of the equipment. The operator must be properly trained. Operators should be familiar with this equipment, the tractor, and all safety practices before starting operation. Read the safety rules and safety decals on page 5 through page 9.

## ⚠ WARNING

- **Safety instructions are important! Read all attachment and power unit manuals; follow all safety rules and safety decal information. (Replacement manuals and safety decals are available from your dealer. To locate your nearest dealer, check the Dealer Locator at [www.WoodsEquipment.com](http://www.WoodsEquipment.com), or in the United States and Canada call 1-800-319-6637.) Failure to follow instructions or safety rules can result in serious injury or death.**
- **Never allow children or untrained persons to operate equipment.**
- **Power unit must be equipped with ROPS and seat belt/operator restraint. Keep seat belt/operator restraint securely fastened/engaged. Falling off power unit can result in death from being run over or crushed. Keep ROPS systems in place at all times.**
- **NEVER GO UNDERNEATH EQUIPMENT. Never place any part of the body underneath equipment or between moveable parts even when the engine has been turned off. Hydraulic system leak-down, hydraulic system failures, mechanical failures, or movement of control levers can cause equipment to drop or rotate unexpectedly and cause severe injury or death.**
  - **Service work does not require going underneath.**
  - **Read Operator's Manual for service instructions or have service performed by a qualified dealer.**
- **Do not allow bystanders in the area when operating, attaching, removing, assembling, or servicing equipment.**
- **Before leaving operator's seat, lower lift arms and put attachment on the ground. Engage brake, stop engine, remove key, and remove seat belt.**
- **Do not exceed loader rated operating capacity with load centered 19.7" (500 mm) from the lift mast.**

The Pallet Fork fits skid steer and front end loaders with a universal mounting coupler (ISO 24410). Read the skid steer or loader manual for instructions on proper operation.

**NOTE:** Model PF1242S2 is equipped with the ISO 24410 coupler but should only be used on subcompact tractor loaders and not skid steer loaders.

## ATTACHING PALLET FORK TO LOADER

### ⚠ WARNING

- **Be sure attachment is properly secured, adjusted, and in good operating condition. Coupler lockpins must be fully extended and properly engaged into attachment retaining slots.**

Read the loader operator's manual connecting and removing instructions.

The loader coupler handles should be in the unlocked position and the lockpins retracted (Figure 1).

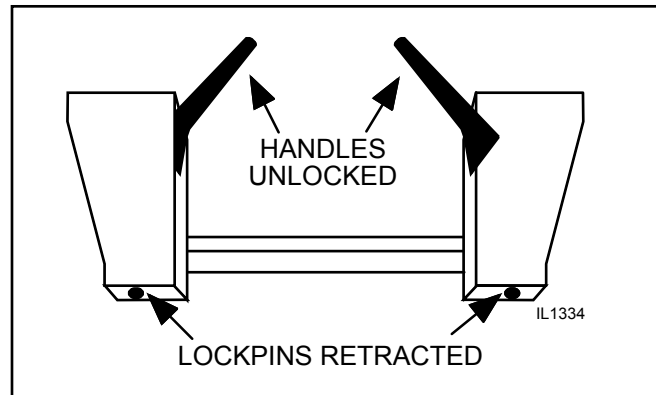

Figure 1. Loader Coupler Handles - Unlocked

Move to the loader operator seat, fasten seat belt, engage operator restraint, and start engine.

Lower loader lift arms to their lowest position.

Carefully move and align the loader coupler to the Pallet Fork. The top of the loader coupler must index into the Pallet Fork flange (Figure 2).

Roll the loader coupler into the Pallet Fork flange so the coupler handles can be engaged.

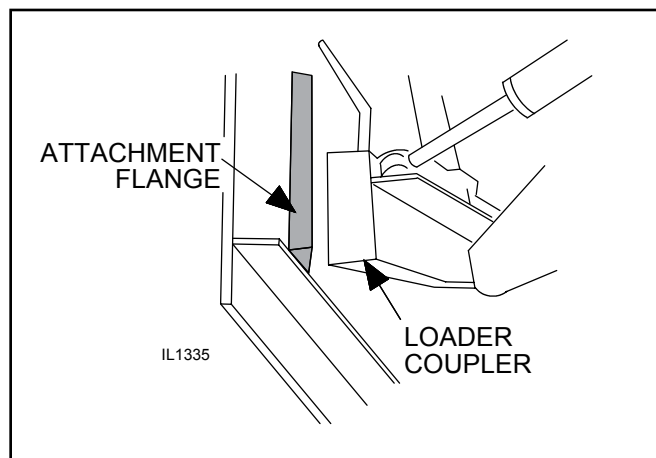
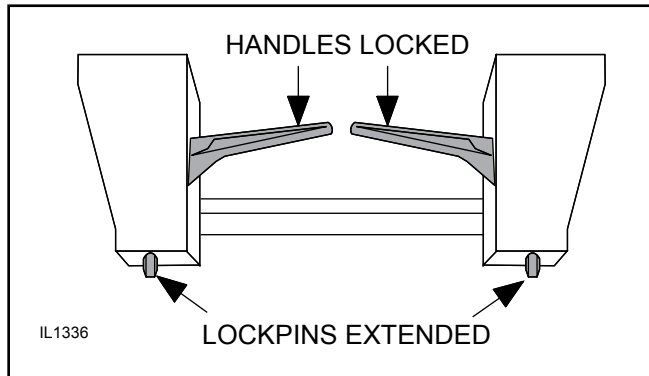

Figure 2. Attaching Pallet Fork to Loader

Shut off the engine, set brake, remove key, remove seat belt, and release operator restraint. Dismount the loader.

Move the loader coupler handles to the locked position. The lockpins must be completely extended and secured into the retaining slots provided on the Pallet-Fork (Figure 3 and Figure 4).



**Figure 3.** Loader Coupler Handles - Locked

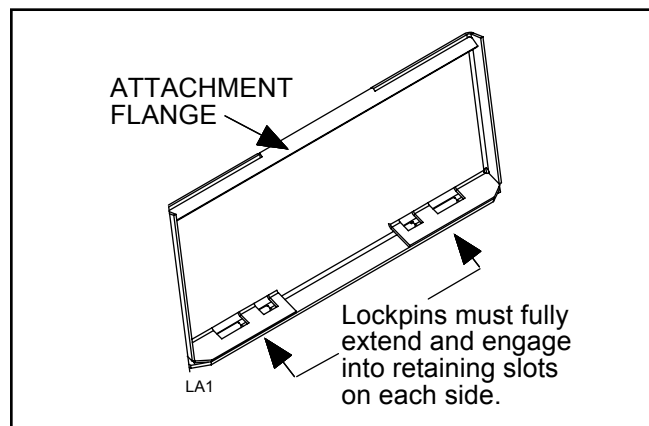

**Figure 4.** Retaining Slot Locations  
Back View of Attachment

## **OPERATING LOADER**

- **Improper operation can cause the machine to tip or roll over and cause injury or death.**
  - **Keep power unit lift arms and attachment as low as possible.**
  - **Do not travel or turn with power unit lift arms and attachment raised.**
  - **Turn only on level ground.**
  - **Go up and down slopes, not across them.**
  - **Keep the heavy end of the machine uphill.**
  - **Do not overload the machine.**

- **Never use attachment to carry loads that exceed the rated operating capacity or other specifications of the power unit. Check your power unit manual or see your dealer for rated operating capacity. Exceeding this capacity can cause machine to tip, roll over, or present other hazards that can cause injury or death.**
- **Look down and to the rear and make sure area is clear before operating in reverse.**
- **TO AVOID SERIOUS INJURY OR DEATH:**
  - **Do not handle round bales or other loads that might shift, slide, or roll off.**
  - **Do not use for digging rocks or lifting concrete slabs.**
  - **Loads must be carried equally on both forks.**
  - **Lift and carry only one item at a time.**
  - **Handle raised load with caution.**
  - **Carry load low.**
  - **Do not exceed loader rated operating capacity with the load centered 19.7" (500 mm) from the lift mast.**

Do not use for shifting loads such as logs or poles.

Loads should be secured on pallets.

Store the forks at low position during transport.

Use adequate power unit ballast to provide stability and good steering control. Do not lift or carry loads that extend above the brick guard. Material may fall into the operator control area.

## **ADJUSTING FORK SPACING**

### **⚠ WARNING**

- **Do not put Pallet Fork into service without forks properly engaged on frame rails and fork lockplate secured in place. Fork locks must be engaged into fork lock notches. Replace if damaged.**
- **Before leaving operator's seat, lower lift arms and put attachment on the ground. Engage brake, stop engine, remove key, and remove seat belt.**

Lower Pallet Fork frame to rest securely on 2x4 wood blocks or other stable support that will position the fork no more than 2" (maximum) above ground surface. Blocks must be placed under each end of the fork frame. The blocks are required so that the attachment is completely lowered and supported before leaving the operator's seat.

Shut off engine, set brake, and remove key before leaving the loader operator's seat.

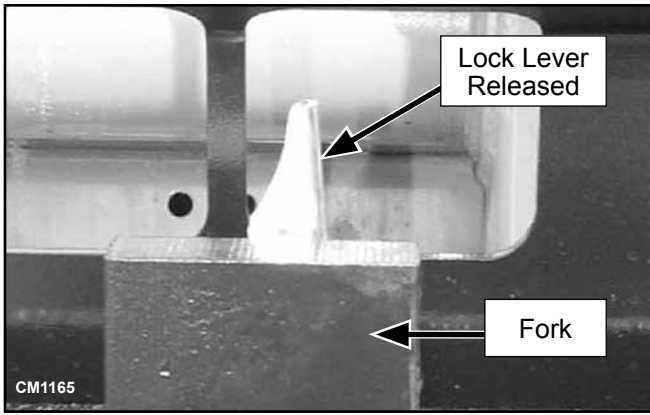

Figure 5. Lock Lever - Released

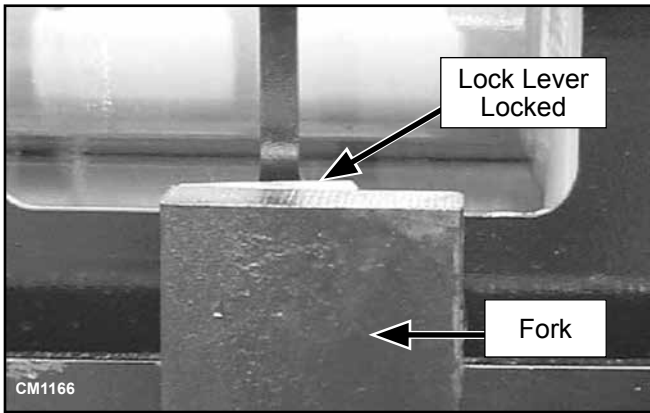

Figure 6. Lock Lever - Locked

## LOCK LEVER

Raise fork locking lever up to “release” position (see Figure 5). Slide fork to desire fork lock notch on upper fork rail. Lower lock lever to engage lock in notch (see Figure 6).

## REMOVING FROM LOADER

On a hard level surface, lower attachment to the ground.

Shut off engine, set brake, remove key, remove seat belt and release operator restraint before leaving the loader operator’s seat.

Move loader coupler handles to the unlocked position (Figure 1). Lockpins must be disengaged from attachment retaining slots.

Move to the loader operator seat, fasten seat belt, engage operator restraint, and start engine.

Release brake and roll loader coupler until it is disengaged from the attachment. The attachment should be placed in storage position.

## STORAGE

### **⚠ WARNING**

- Block equipment securely for storage.

### **⚠ CAUTION**

- Keep children, bystanders, and animals away from the equipment and the storage area

Inspect the Pallet Fork thoroughly and prepare for storage. Repair or replace any damaged components.

Remove Pallet Fork as described in “Removing From Loader.” Rest forks flat on the ground in a stable position.

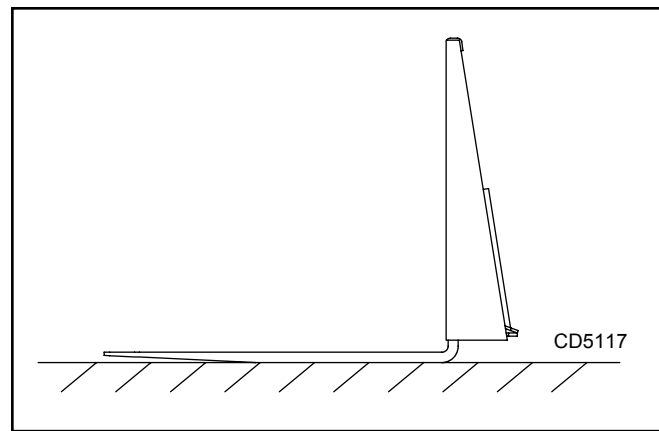

Figure 7. Storage Position

## PRE-OPERATION CHECKLIST

### (OWNER’S RESPONSIBILITY)

- \_\_\_\_\_ Review and follow all safety rules and safety decal instructions on page 5 through page 9.
- \_\_\_\_\_ Check that all safety decals are installed and in good condition. Replace if damaged.
- \_\_\_\_\_ Check that shields and guards are properly installed and in good condition. Replace if damaged.
- \_\_\_\_\_ Check that all hardware and cotter pins are properly installed and secured.
- \_\_\_\_\_ Check that equipment is properly and securely attached to loader.
- \_\_\_\_\_ Do not allow riders.
- \_\_\_\_\_ Make sure power unit ROPS and seat belt are in good condition. Keep seat belt securely fastened during operation.
- \_\_\_\_\_ Check that forks are properly engaged on frame rails, fork lockplate is secured and fork locks are engaged into rail lock notches. Replace if damaged.

# OWNER SERVICE

The information in this section is written for operators who possess basic mechanical skills. If you need help, your dealer has trained service technicians available. For your protection, read and follow the safety information in this manual.

## WARNING

- **Safety instructions are important! Read all attachment and power unit manuals; follow all safety rules and safety decal information.** (Replacement manuals and safety decals are available from your dealer. To locate your nearest dealer, check the Dealer Locator at [www.WoodsEquipment.com](http://www.WoodsEquipment.com), or in the United States and Canada call 1-800-319-6637.) Failure to follow instructions or safety rules can result in serious injury or death.
- **NEVER GO UNDERNEATH EQUIPMENT.** Never place any part of the body underneath equipment or between moveable parts even when the engine has been turned off. Hydraulic system leak-down, hydraulic system failures, mechanical failures, or movement of control levers can cause equipment to drop or rotate unexpectedly and cause severe injury or death.
  - Service work does not require going underneath.
  - Read Operator's Manual for service instructions or have service performed by a qualified dealer.
- Make sure shields and guards are properly installed and in good condition. Replace if damaged.
- Before leaving operator's seat, lower lift arms and put attachment on the ground. Engage brake, stop engine, remove key, and remove seat belt.
- Before performing service work that requires repair or replacement of parts, remove attachment from power unit. Hydraulic system failures, mechanical failures, or movement of control can cause equipment to drop or rotate unexpectedly and cause severe injury or death.
- Keep all persons away from operator control area while performing adjustments, service, or maintenance.
- Fork Tines are heavy and can cause muscle strain or back injury. Use lifting aids and proper lifting techniques when installing and removing.

## CAUTION

- If you do not understand any part of this manual and need assistance, see your dealer.
- Always wear relatively tight and belted clothing to avoid getting caught in moving parts. Wear sturdy, rough-soled work shoes and protective equipment for eyes, hair, hands, hearing, and head; and respirator or filter mask where appropriate.
- Tighten all bolts, nuts, and screws to torque chart specifications. Check that all cotter pins are installed securely to ensure equipment is in a safe condition before putting unit into service.

## DAILY SERVICE

Apply a small amount of grease to the front and top surfaces of the upper fork rail daily. This will allow the forks to be adjusted easily.

Inspect fork locks; repair or replace if damaged.

Inspect forks and fork lugs. Fork lugs must be securely engaged over upper and lower rails. Replace any fork that is bent or twisted.

## FORK REMOVAL

### WARNING

- Fork Tines are heavy and can cause muscle strain or back injury. Use lifting aids and proper lifting techniques when installing and removing.

Lower Pallet Fork frame to rest securely on 2x4 wood blocks or other stable support that will position the fork no more than 2" (maximum) above ground surface. Blocks must be placed under each end of the fork frame. The blocks are required so that the attachment is completely lowered and supported before leaving the operator's seat.

Remove lockplate and cap screw.

Move fork lock lever to "release" position (Figure 5) and slide fork to center of fork rails.

Align lower fork retainer with slot in lower fork rail.

Raise front of fork to disengage lower fork retainer.

Lift fork and disengage upper fork rail.

## FORK INSTALLATION

### **WARNING**

- **Fork Tines are heavy and can cause muscle strain or back injury. Use lifting aids and proper lifting techniques when installing and removing.**

Support forklift frame as described in the Fork Removal section.

Move fork lock lever to “released” position (Figure 5).

Working at the center of the Pallet Fork frame, engage the upper fork retainer over upper fork rail.

Place lower fork retainer through the slot in the lower fork rail.

Slide fork to the desired locking notch, in the upper fork rail, and move lock lever to “locked” position (Figure 6).

Repeat installation for second fork.

Install fork lockplate and tighten cap screw to specifications in torque chart on page 19.

Fork lockplate must be installed to prevent forks from entering fork assembly slot and falling off during operation. Remove lockplate only to remove and install fork. Do not operate with lockplate removed.

## CLEANING

### After Each Use

- **Remove large debris such as clumps of dirt, grass, crop residue, etc. from machine.**
- **Inspect machine and replace worn or damaged parts.**
- **Replace any safety decals that are missing or not readable.**

### Periodically or Before Extended Storage

- **Clean large debris such as clumps of dirt, grass, crop residue, etc. from machine.**
- **Remove the remainder using a low-pressure water spray.**
  1. Be careful when spraying near scratched or torn safety decals or near edges of decals as water spray can peel decal off surface.
  2. Be careful when spraying near chipped or scratched paint as water spray can lift paint.
  3. If a pressure washer is used, follow the advice of the pressure washer manufacturer.
- **Inspect machine and replace worn or damaged parts.**
- **Sand down scratches and the edges of areas of missing paint and coat with spray paint of matching color.**
- **Replace any safety decals that are missing or not readable. See Safety Decals section for location drawing.**

# ASSEMBLY

## DEALER SET-UP INSTRUCTIONS

Assembly of this equipment is the responsibility of the Woods dealer. It should be delivered to the owner completely assembled, lubricated, and adjusted for normal operating conditions.

Complete checklists on page 16 when you have completed the assembly.

### WARNING

- **Safety instructions are important! Read all attachment and power unit manuals; follow all safety rules and safety decal information. (Replacement manuals and safety decals are available from your dealer. To locate your nearest dealer, check the Dealer Locator at [www.WoodsEquipment.com](http://www.WoodsEquipment.com), or in the United States and Canada call 1-800-319-6637.) Failure to follow instructions or safety rules can result in serious injury or death.**
- **Operators must be instructed in and be capable of the safe operation of the equipment, its attachments, and all controls. Do not allow anyone to operate this equipment without proper instructions.**
- **Do not modify or alter or permit anyone else to modify or alter the equipment or any of its components in any way.**
- **Keep all persons away from operator control area while performing adjustments, service, or maintenance.**
- **If you do not understand any part of this manual and need assistance, see your dealer.**
- **Fork Tines are heavy and can cause muscle strain or back injury. Use lifting aids and proper lifting techniques when installing and removing.**

Before proceeding, make sure you read and follow all instructions and safety rules in this manual and the loader manual.

If any parts do not fit, contact your Woods representative or the factory for more information.

Check bundle numbers with the shipping list to ensure you have all parts needed to begin assembling your fork.

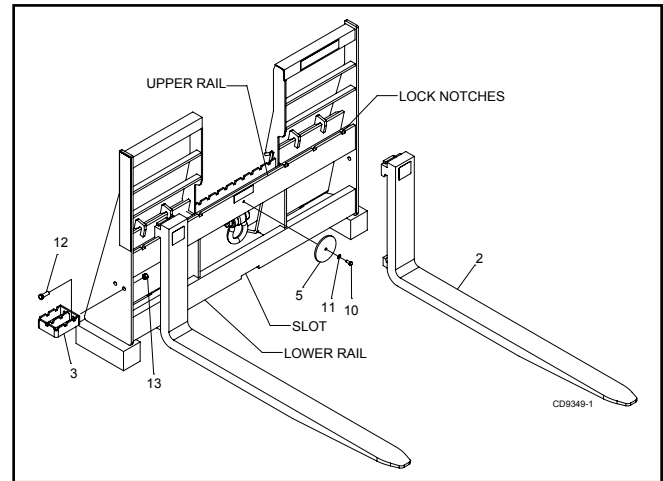

Figure 8. Pallet Fork Assembly

### Assemble Pallet Fork

1. Attach Pallet Fork frame to loader, see Attaching Pallet Fork to Loader on page 10.
2. Lower Pallet Fork frame to rest securely on 2x4 wood blocks or other stable support that will position the fork no more than 2" (maximum) above ground surface. Blocks must be placed under each end of the fork frame. The blocks are required so that the attachment is completely lowered and supported before leaving the operator's seat.
3. Remove lockplate (5) by loosening cap screw (10) and washer (11).
4. Move fork lock lever to "released" position (Figure 5).
5. Working at the center of the Pallet Fork frame, engage the upper fork retainer over upper fork rail. Place lower fork retainer through the slot in the lower fork rail.
6. Slide fork to the desired locking notch in the upper fork rail and move lock lever to "locked" position (Figure 6).
7. Repeat installation for second fork.
8. Install fork lockplate (5) and tighten cap screw (10) and washer (11) to specifications in torque chart on page 19.

**NOTE:** Fork lockplate must be installed to prevent forks from entering fork assembly slot and falling off during operation. Remove lockplate only to remove and install forks. Do not operate with lockplate removed.

### Install Step Kit 1019883 (Optional)

Install step (3) on side of frame using cap screws (12) and lock nuts (13).

# DEALER CHECKLISTS

## DEALER PRE-DELIVERY CHECKLIST

### (DEALER'S RESPONSIBILITY)

Inspect the equipment thoroughly after assembly to ensure it is set up properly before delivering it to the customer.

The following checklists are a reminder of points to inspect. Check off each item as it is found satisfactory or after proper adjustment is made.

- \_\_\_\_\_ Check that all safety decals are installed and in good condition. Replace if damaged.
- \_\_\_\_\_ Check all bolts to be sure they are properly torqued.
- \_\_\_\_\_ Check that all cotter pins and safety pins are properly installed. Replace if damaged.
- \_\_\_\_\_ Check and grease all lubrication points.
- \_\_\_\_\_ Check that forks are properly engaged on frame rails, fork lockplate is secured and fork locks are engaged into rail lock notches. Replace if damaged.

## DELIVERY CHECKLIST

### (DEALER'S RESPONSIBILITY)

- \_\_\_\_\_ Show customer how to make adjustments.
- \_\_\_\_\_ Instruct customer how to lubricate and explain importance of lubrication.
- \_\_\_\_\_ Point out the safety decals. Explain their meaning and the need to keep them in place and in good condition. Emphasize the increased safety hazards when instructions are not followed.
- \_\_\_\_\_ Present Operator's Manual and request that customer and all operators read it before operating equipment. Point out the manual safety rules, explain their meanings and emphasize the increased safety hazards that exist when safety rules are not followed.
- \_\_\_\_\_ Explain to customer the potential crushing hazards of going underneath raised equipment. Instruct customer that service work does not require going underneath unit and never to do so.
- \_\_\_\_\_ Show customer the safe, proper procedures to be used when mounting, dismounting, and storing equipment.
- \_\_\_\_\_ Explain to customer that when equipment is transported on a road or highway, safety devices should be used to give adequate warning to operators of other vehicles.
- \_\_\_\_\_ Make customer aware of optional equipment available so that customer can make proper choices as required.

## PF1242S2 PALLET FORK PARTS LIST

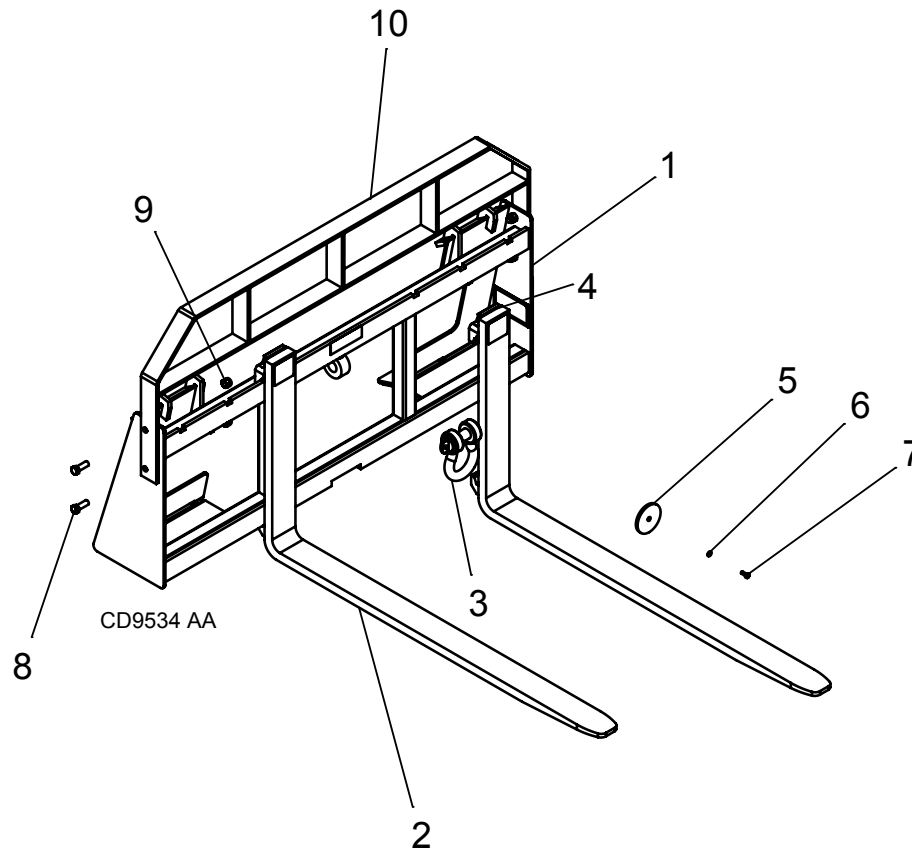

REF	PART	QTY	DESCRIPTION
1	NSS	1	PALLET FORK FRAME
2	657171RP	1	FORK TINE 1 X 3 X 42
3	S49040800	1	CLEVIS, 7/8 IN FARM
4	602512	2	KIT, REPAIR LOCKDOWN PF
5	1019882RP	1	ROUND FORK STOP
6	21656	1*	WASHER, 8 MM LOCK
7	24801	1*	HHCS M8 -1.25P X 20MM CL8.8
8	23029	4*	M12 - 1.75 - 25MM CL 8.8
9	58549	4*	M12 - 1.75 NYLOCK NUT
10	657187	1	BRICK GUARD, PF1242S2
NS	657172	1	DECAL, CAPACITY 1200

\* STANDARD HARDWARE,  
OBTAIN LOCALLY

NS NOT SHOWN

NSS NOT SOLD SEPERATELY

**NOTE:** FOR SAFETY DECALS SEE PAGES 8-9 . ORDER DECALS SEPERATELY

# PFW SERIES 2 PALLET FORK PARTS LIST

MODELS - PFW2242S2, PFW4442S2, PFW4448S2, PF4448S2, PFW6648S2

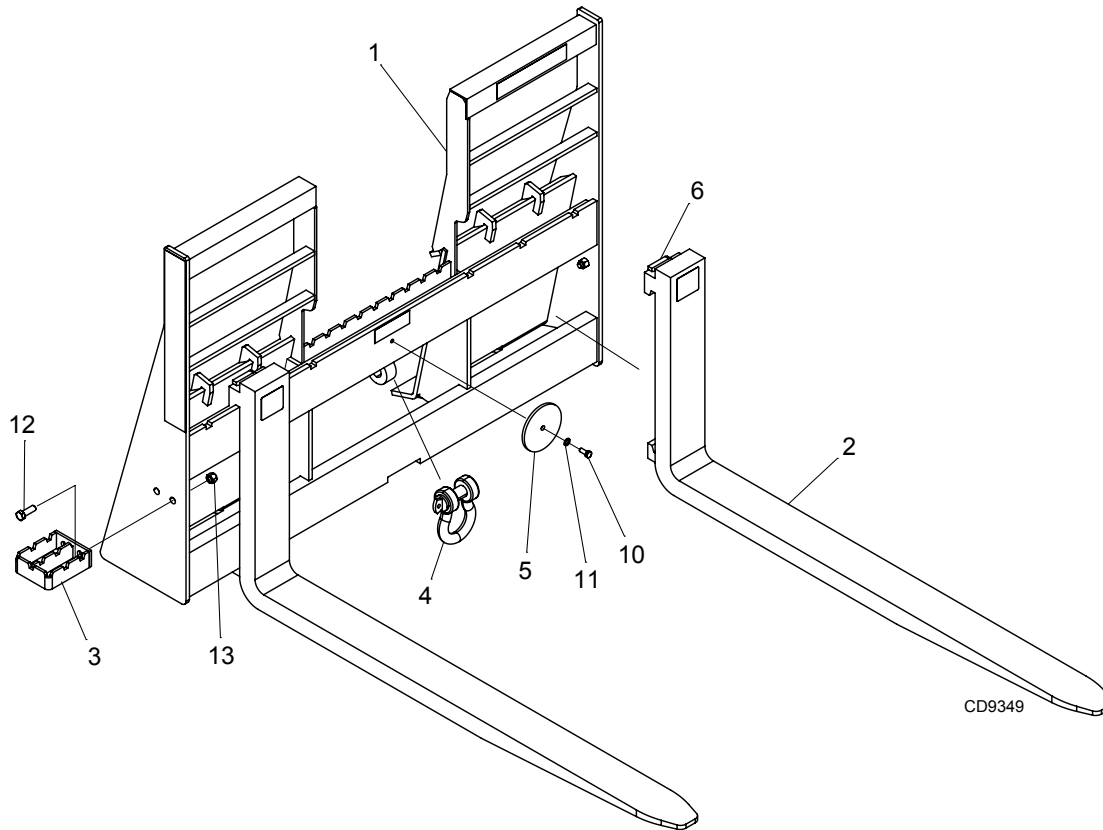

REF	PART	QTY	DESCRIPTION	USED ON
1	NSS	1	PALLET FORK FRAME	
2	602497RP	2	FORK TINE, 1.2 X 3.2 X 42	PFW2242S2
	602509RP	2	FORK TINE, 1.4 X 3.9 X 42	PFW4442S2
	602510RP	2	FORK TINE, 1.4 X 3.9 X 48	PFW4448S2, PF4448S2
	602511RP	2	FORK TINE, 1.8 X 3.9 X 48	PFW6648S2
3	1019883	1	STEP KIT (OPTIONAL) includes 3, 12, 13	ALL (one step supplied with PF4448S2)
4	S49040800	1	CLEVIS, 7/8 IN FARM	ALL
5	1019882RP	1	STOP, ROUND FORK	ALL
6	602512	2	KIT, REPAIR KIT LOCKDOWN PF	ALL
10	24801	1*	HHCS M8-1.25P X 20MM CL8.8	ALL
11	21656	1*	WASHER, 8MM LOCK	ALL
12	62584	4*	HHCS M12-1.75P X 35MM	ALL
13	58549	4*	NUT LOCK M12-1.75P ZP	ALL
NS	78760	1	DECAL, MODEL, WOODS WHITE	ALL
NS	1046087	1	DECAL, CAPACITY 2200	PFW2242S2
NS	1046088	1	DECAL, CAPACITY 4400	PFW4442S2, PFW4448S2, PF4448S2
NS	1046089	1	DECAL, CAPACITY 6600	PFW6648S2

\* STANDARD HARDWARE, OBTAIN LOCALLY

NS NOT SHOWN

NSS NOT SOLD SEPERATELY

**NOTE:** FOR SAFETY DECALS SEE PAGES 8-9 . ORDER DECALS SEPERATELY

## 18 Parts

MAN1354  
(04/29/2026)

# BOLT TORQUE CHART

Always tighten hardware to these values unless a different torque value or tightening procedure is listed for a specific application.

Fasteners must always be replaced with the same grade as specified in the manual parts list.

Always use the proper tool for tightening hardware: SAE for SAE hardware and Metric for metric hardware. Make sure fastener threads are clean and you start thread engagement properly.

All torque values are given to specifications used on hardware defined by SAE J1701 MAR 99 & J1701M JUL 96.

## SAE SERIES TORQUE CHART

SAE Bolt Head Identification

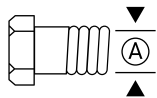

SAE Grade 2  
(No Dashes)



SAE Grade 5  
(3 Radial Dashes)



SAE Grade 8  
(6 Radial Dashes)

Ⓐ	Diameter (Inches)	Wrench Size	Marking on Head					
			SAE 2		SAE 5		SAE 8	
			lbs-ft	N-m	lbs-ft	N-m	lbs-ft	N-m
1/4"	7/16"	6	8	10	13	14	18	
5/16"	1/2"	12	17	19	26	27	37	
3/8"	9/16"	23	31	35	47	49	67	
7/16"	5/8"	36	48	55	75	78	106	
1/2"	3/4"	55	75	85	115	120	163	
9/16"	13/16"	78	106	121	164	171	232	
5/8"	15/16"	110	149	170	230	240	325	
3/4"	1-1/8"	192	261	297	403	420	569	
7/8"	1-5/16"	306	416	474	642	669	907	
1"	1-1/2"	467	634	722	979	1020	1383	

## TYPICAL WASHER INSTALLATIONS

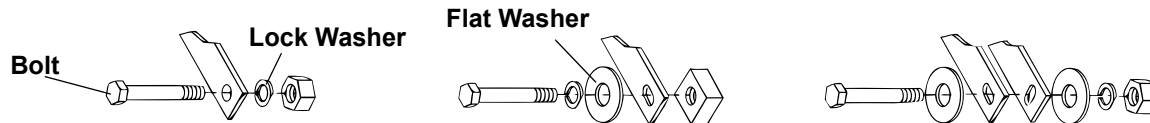

## METRIC SERIES TORQUE CHART

Metric Bolt Head Identification

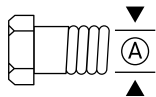

Metric  
Grade 8.8



Metric  
Grade 10.9

Ⓐ	Diameter & Thread Pitch (Millimeters)	Wrench Size	Marking on Head								Ⓐ	Diameter & Thread Pitch (Millimeters)
			Coarse Thread				Fine Thread					
			Metric 8.8		Metric 10.9		Metric 8.8		Metric 10.9			
N-m	lbs-ft	N-m	lbs-ft	N-m	lbs-ft	N-m	lbs-ft	N-m	lbs-ft			
6 x 1.0	10 mm	8	6	11	8	8	6	11	8	6 x 1.0		
8 x 1.25	13 mm	20	15	27	20	21	16	29	22	8 x 1.0		
10 x 1.5	16 mm	39	29	54	40	41	30	57	42	10 x 1.25		
12 x 1.75	18 mm	68	50	94	70	75	55	103	76	12 x 1.25		
14 x 2.0	21 mm	109	80	151	111	118	87	163	120	14 x 1.5		
16 x 2.0	24 mm	169	125	234	173	181	133	250	184	16 x 1.5		
18 x 2.5	27 mm	234	172	323	239	263	194	363	268	18 x 1.5		
20 x 2.5	30 mm	330	244	457	337	367	270	507	374	20 x 1.5		
22 x 2.5	34 mm	451	332	623	460	495	365	684	505	22 x 1.5		
24 x 3.0	36 mm	571	421	790	583	623	459	861	635	24 x 2.0		
30 x 3.0	46 mm	1175	867	1626	1199	1258	928	1740	1283	30 x 2.0		

# BOLT SIZE CHART

**NOTICE:** Chart shows bolt thread sizes and corresponding head (wrench) sizes for standard SAE and metric bolts.

## SAE BOLT THREAD SIZES

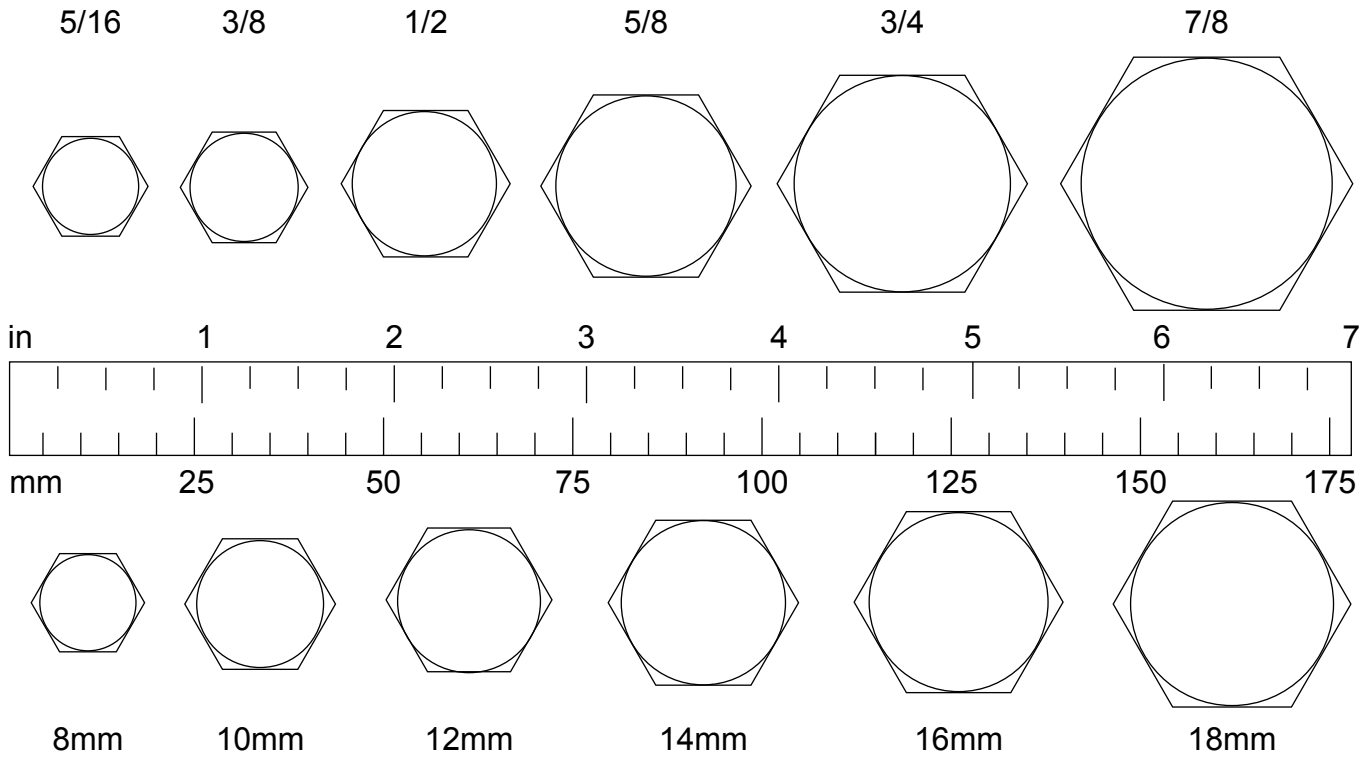

## METRIC BOLT THREAD SIZES

## ABBREVIATIONS

AG . . . . . Agriculture	HT . . . . . Heat-Treated	ORBM . . . . . O-Ring Boss - Male
ASABE . . . . . American Society of Agricultural & Biological Engineers (formerly ASAE)	JIC . . . . . Joint Industry Council 37° Degree Flare	P . . . . . Pitch
ASAE . . . . . American Society of Agricultural Engineers	LH . . . . . Left Hand	PBY . . . . . Power-Beyond
ATF . . . . . Automatic Transmission Fluid	LT . . . . . Left	psi . . . . . Pounds per Square Inch
BSPP . . . . . British Standard Pipe Parallel	m . . . . . Meter	PTO . . . . . Power Take Off
BSPTM . . . . . British Standard Pipe Tapered Male	mm . . . . . Millimeter	QD . . . . . Quick Disconnect
CV . . . . . Constant Velocity	M . . . . . Male	RH . . . . . Right Hand
CCW . . . . . Counter-Clockwise	MPa . . . . . Mega Pascal	ROPS . . . . . Roll-Over Protective Structure
CW . . . . . Clockwise	N . . . . . Newton	RPM . . . . . Revolutions Per Minute
F . . . . . Female	NC . . . . . National Coarse	RT . . . . . Right
FT . . . . . Full Thread	NF . . . . . National Fine	SAE . . . . . Society of Automotive Engineers
GA . . . . . Gauge	NPSM . . . . . National Pipe Straight Mechanical	UNC . . . . . Unified Coarse
GR (5, etc.) . . . . . Grade (5, etc.)	NPT . . . . . National Pipe Tapered	UNF . . . . . Unified Fine
HHCS . . . . . Hex Head Cap Screw	NPT SWF . . . . . National Pipe Tapered Swivel Female	UNS . . . . . Unified Special

# INDEX

## ASSEMBLY

Dealer Set-Up Instructions 15

## DEALER CHECKLISTS

Delivery (Dealer's Responsibility) 16

Pre-Delivery (Dealer's Responsibility) 16

## GENERAL

Abbreviations 20

Bolt Size Chart 20

Bolt Torque Chart 19

General Information 4

Introduction 2

Obtaining Replacement Manuals 2

Specifications 4

Table of Contents 3

Warranty 2

## OPERATION

Adjusting Fork Spacing 11

Attaching Pallet Fork to Loader 10

Operating Implement 11

Pre-Operation Checklist

(Owner's Responsibility) 12

Removing from Loader 12

Storage 12

## OWNER SERVICE

Cleaning

After Each Use 14

Periodically or Before Extended Storage 14

Daily Service 13

Fork Installation 14

Fork Removal 13

## PARTS

Parts List 17

## SAFETY

Checklists

Delivery (Dealer's Responsibility) 16

Pre-Delivery (Dealer's Responsibility) 16

Pre-Operation (Owner's Responsibility) 12

Safety Decals 8-9

Safety Rules 5-7

Safety Symbols Explained 2

**PART NO.**  
**MAN1354**

**WOODS®**

2606 South Illinois Route 2  
Post Office Box 1000  
Oregon, Illinois 61061 USA

800-319-6637 tel  
800-399-6637 fax  
woodsequipment.com



© 2026 Woods Equipment Company. All rights reserved. Woods® and the Woods logo are trademarks of Woods Equipment Company. All other trademarks, trade names, or service marks not owned by Woods Equipment Company that appear in this manual are the property of their respective companies or mark holders. Specifications subject to change without notice.