

BATWING[®] ROTARY CUTTER

BW15.71

BW15.71Q

BW10.71

BW10.71Q

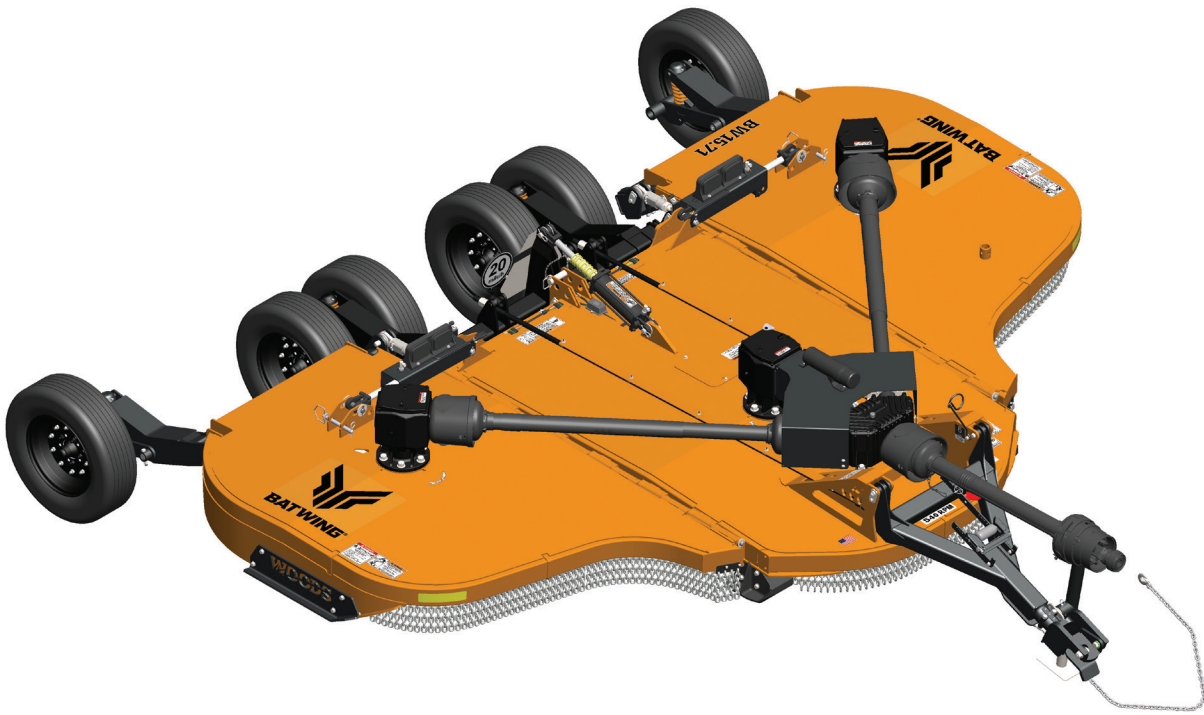

MAN1339
(Rev 11/04/2023)

WOODS[®]

OPERATOR'S MANUAL

TO THE DEALER:

Assembly and proper installation of this product is the responsibility of the Woods® dealer. Read manual instructions and safety rules. Make sure all items on the Dealer's Pre-Delivery and Delivery Checklists in the Operator's Manual are completed before releasing equipment to the owner.

The dealer must complete the online Product Registration form at the Woods Dealer Website which certifies that all Dealer Checklist items have been completed. Dealers can register all Woods product at dealer.WoodsEquipment.com under Product Registration.

Failure to register the product does not diminish customer's warranty rights.

TO THE OWNER:

Read this manual before operating your Woods equipment. The information presented will prepare you to do a better and safer job. Keep this manual handy for ready reference. Require all operators to read this manual carefully and become acquainted with all adjustment and operating procedures before attempting to operate. Replacement manuals can be obtained from your dealer. To obtain complete warranty details, visit WoodsEquipment.com/warranty. You may also request a hard copy by calling 1-800-319-6637 or mail your request to: Woods Equipment Company, Attn: Warranty Dept. 2606 South Illinois Route 2, Oregon, IL 61061. To locate your nearest dealer, check the Dealer Locator at www.WoodsEquipment.com, or in the United States and Canada call 1-800-319-6637.

The equipment you have purchased has been carefully engineered and manufactured to provide dependable and satisfactory use. Like all mechanical products, it will require cleaning and upkeep. Lubricate the unit as specified. Observe all safety information in this manual and safety decals on the equipment.

For service, your authorized Woods dealer has trained mechanics, genuine Woods service parts, and the necessary tools and equipment to handle all your needs.

Use only genuine Woods service parts. Substitute parts will void the warranty and may not meet standards required for safe and satisfactory operation. Record the model number and serial number of your equipment in the spaces provided:

Model: _____ **Date of Purchase:** _____

Serial Number: (see Safety Decal section for location) _____

Provide this information to your dealer to obtain correct repair parts.

Throughout this manual, the term **NOTICE** is used to indicate that failure to observe can cause damage to equipment. The terms **CAUTION**, **WARNING**, and **DANGER** are used in conjunction with the Safety-Alert Symbol (a triangle with an exclamation mark) to indicate the degree of hazard for items of personal safety.



This is the safety alert symbol. It is used to alert you to potential physical injury hazards. Obey all safety messages that follow this symbol to avoid possible injury or death.



Indicates a hazardous situation that, if not avoided, will result in death or serious injury.



Indicates a hazardous situation that, if not avoided, could result in death or serious injury.



Indicates a hazardous situation that, if not avoided, could result in minor or moderate injury.

**IMPORTANT
or NOTICE**

Is used to address practices not related to physical injury.

NOTE

Indicates helpful information.

TABLE OF CONTENTS

INTRODUCTION	2
SPECIFICATIONS	4
GENERAL INFORMATION	4
SAFETY	5
MOWER SAFETY VIDEO	5
SAFETY RULES	7
INSTALLATION	7
TRAINING	7
PREPARATION	7
TRANSPORTATION	8
OPERATION	8
MAINTENANCE	9
STORAGE	10
SAFETY & INSTRUCTIONAL DECALS	11
OPERATION	14
OPERATION	14
CONNECTING CUTTER TO TRACTOR	14
TRACTOR OPERATION	16
CUTTER OPERATION	16
TRANSPORTING	17
STORAGE	18
PRE-OPERATION CHECKLIST	18
OWNER SERVICE	19
OWNER SERVICE	19
BLOCKING METHOD	19
LUBRICATION	20
BLADES	21
SLIP CLUTCH ADJUSTMENT	22
SHIELDING REPAIR	23
SERVICING TIRES SAFELY	23
CLEANING	23
TROUBLESHOOTING	24
DEALER SERVICE	25
DEALER SERVICE	25
GEARBOX MAINTENANCE	25
GEARBOX REPAIR	26
SPLITTER GEARBOX REPAIR	28
CROSSBAR REMOVAL	30
CROSSBAR INSTALLATION	31
UNIVERSAL JOINT REPAIR	31
SERVICING TIRES SAFELY	32
ASSEMBLY	33
DEALER SET-UP INSTRUCTIONS	33
DEALER CHECKLISTS	35
PARTS INDEX	36
APPENDIX	60
BOLT TORQUE CHART	60
BOLT SIZE CHART & ABBREVIATIONS	61
INDEX	62

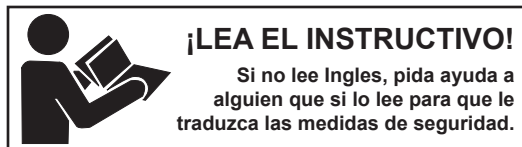

 This Operator's Manual should be regarded as part of the machine. Suppliers of both new and second-hand machines must make sure that this manual is provided with the machine.

SPECIFICATIONS

	BW15.71 / BW15.71Q	BW10.71 / BW10.71Q
Cutting Height (Varies with tire selection)	1" - 15"	1" - 15"
Cutting Width	180" (15')	126" (10.5')
Overall Width	190"	140"
Transport Width	96"	93"
Transport Height	85-90"	85-90"
Tractor HP	300	300
Tractor Min. PTO hp	65	65
Tractor PTO rpm	540/1000	540/1000
Blade Spindle	3	2
Blade Overlap	6"	6"
Number of Blades	6	4
Blade Rotation	Left Spindle: CW; Right & Center Spindles: CCW	
Blade Speed (feet per minute)	16,000	16,000
Wing Driveline	Cat 5	Cat 5
CV Driveline	Cat 6	Cat 6
Side Frame Thickness	1/4"	1/4"
Weight (approximate lbs.)	4840	5051
Tongue Weight (approximate lbs.)	1470	1470
Wheel Size	15" Rims (BW15.71 and BW15.71Q only), 21" OD Solid Tires, 25" Severe Duty, 29" Airplane	
Torsion Protection	Slip Clutch	Slip Clutch

GENERAL INFORMATION

WARNING

- Some illustrations in this manual show the mower with safety shields removed to provide a better view. The mower should never be operated with any safety shielding removed.

The purpose of this manual is to assist you in operating and maintaining your cutter. Read it carefully. It furnishes information and instructions that will help you achieve years of dependable performance. These instructions have been compiled from extensive field experience and engineering data. Some information may be general in nature due to unknown and varying operating conditions. However, through experience

and these instructions, you should be able to develop procedures suitable to your particular situation.

The illustrations and data used in this manual were current at the time of printing but, due to possible inline production changes, your machine may vary slightly in detail. We reserve the right to redesign and change the machines as may be necessary without notification.

Throughout this manual, references are made to right and left directions. These are determined by standing behind the equipment facing the direction of forward travel. Blade rotation is clockwise (left wing) and counterclockwise (right wing and center section) as viewed from the top of the cutter.

NOTICE:

If you would like to receive a free Spanish language translation of the Safety Rules section of this manual, plus a set of Spanish language safety decals, please contact your local Woods dealer.

AVISO:

Si desea recibir una traducción al español gratuita de la sección de Reglas de seguridad de este manual y un juego de etiquetas de seguridad en español, por favor comuníquese con su concesionario local de Woods.

BE SAFE!

BE ALERT!

BE ALIVE!

BE TRAINED

Before Operating Mowers!



ASSOCIATION OF
EQUIPMENT
MANUFACTURERS

*Safety Training
Does Make a Difference.*

Watch a Mower Safety Video Online

The AEM (Association of Equipment Manufacturers) offers a safety training video, *Industrial and Agricultural Mower Safety Practices*. The 22-minute video can be viewed online for free at TheAEMStore,

<https://youtu.be/EuktqJNAjhc>

It reinforces the proper procedures to follow while operating your mowing equipment. The video does not replace the information contained in the Operator's Manual, so please review this manual thoroughly before operating your new mowing equipment.

Also, available from the Association of Equipment Manufacturers:

A large variety of training materials (ideal for groups) are available for a nominal charge from AEM. Following is a partial list:

- **Training Package for Rotary Mowers/Cutters-English**

Contains: DVD & VHS (English)

 Guidebook for Rotary Mowers/Cutters (English)

 AEM Industrial/Agricultural Mower Safety Manual (English)

 AEM Agricultural Tractor Safety Manual (English)

- **Training Package for Rotary Mowers/Cutters-English/Spanish**

Contains: DVD & VHS (English/Spanish)

 Guidebook for Rotary Mowers/Cutters (English/Spanish)

 AEM Industrial/Agricultural Mower Safety Manual (English/Spanish)

 AEM Agricultural Tractor Safety Manual (English/Spanish)

AEM training packages are available through:

AEM at: www.aem.org

or

Universal Lithographers, Inc.

Email: aem@ulilitho.com

800-369-2310 tel

866-541-1668 fax

SAFETY RULES



ATTENTION! BECOME ALERT! YOUR SAFETY IS INVOLVED!



Safety is a primary concern in the design and manufacture of our products. Unfortunately, our efforts to provide safe equipment can be wiped out by an operator's single careless act.

In addition to the design and configuration of equipment, hazard control and accident prevention are dependent upon the awareness, concern, judgement, and proper training of personnel involved in the operation, transport, maintenance, and storage of equipment.

It has been said, "The best safety device is an informed, careful operator." We ask you to be that kind of operator.

INSTALLATION

- Hydraulics must be connected as instructed in this manual. Do not substitute parts, modify, or connect in any other way.

TRAINING

- Safety instructions are important! Read all attachment and power unit manuals; follow all safety rules and safety decal information. (Replacement manuals and safety decals are available from your dealer. To locate your nearest dealer, check the Dealer Locator at www.WoodsEquipment.com, or in the United States and Canada call 1-800-319-6637.) Failure to follow instructions or safety rules can result in serious injury or death.
- If you do not understand any part of this manual and need assistance, see your dealer.
- Know your controls and how to stop engine and attachment quickly in an emergency.
- Operators must be instructed in and be capable of the safe operation of the equipment, its attachments, and all controls. Do not allow anyone to operate this equipment without proper instructions.
- Keep hands and body away from pressurized lines. Use paper or cardboard, not hands or other body parts to check for leaks. Wear safety goggles. Hydraulic fluid under pressure can easily penetrate skin and will cause serious injury or death.
- Make sure that all operating and service personnel know that if hydraulic fluid penetrates skin, it must be surgically removed as soon as possible by a doctor familiar with this form of injury or gangrene, serious injury, or death will result.

CONTACT A PHYSICIAN IMMEDIATELY IF FLUID ENTERS SKIN OR EYES. DO NOT DELAY.

- Never allow children or untrained persons to operate equipment.

PREPARATION

- Check that all hardware is properly installed. Always tighten to torque chart specifications unless instructed otherwise in this manual.
- Air in hydraulic systems can cause erratic operation and allows loads or equipment components to drop unexpectedly. When connecting equipment or hoses or performing any hydraulic maintenance, purge any air in hydraulic system by operating all hydraulic functions several times. Do this before putting into service or allowing anyone to approach the equipment.
- Make sure all hydraulic hoses, fittings, and valves are in good condition and not leaking before starting power unit or using equipment. Check and route hoses carefully to prevent damage. Hoses must not be twisted, bent sharply, kinked, frayed, pinched, or come into contact with any moving parts. Operate moveable components through full operational range to check clearances. Replace any damaged hoses immediately.
- After connecting hoses, check that all control lever positions function as instructed in the Operator's Manual. Do not put into service until control lever and equipment movements are correct.
- Set tractor hydraulic relief valve at 2500 psi (170 bars) (17,000 kPa) to prevent injury and equipment damage due to hydraulic system failure.
- Your dealer can supply original equipment hydraulic accessories and repair parts. Substitute parts may not meet original equipment specifications and may be dangerous.
- Always wear relatively tight and belted clothing to avoid getting caught in moving parts. Wear sturdy, rough-soled work shoes and protective equipment for eyes, hair, hands, hearing, and head; and respirator or filter mask where appropriate.
- Make sure attachment is properly secured, adjusted, and in good operating condition.
- Make sure spring-activated locking pin or collar slides freely and is seated firmly in tractor PTO spline groove.

(Safety Rules continued on next page)

SAFETY RULES



ATTENTION! BECOME ALERT! YOUR SAFETY IS INVOLVED!



(Safety Rules continued from previous page)

- If installed, make sure driveline guard tether chains are attached to the tractor and equipment as shown in the pamphlet that accompanies the driveline. Replace if damaged or broken. Check that driveline guards rotate freely on driveline before putting equipment into service.
- Before starting power unit, check all equipment driveline guards for damage. Replace any damaged guards. Make sure all guards rotate freely on all drivelines. If guards do not rotate freely on drive-lines, repair and replace bearings before putting equipment into service.
- Remove accumulated debris from this equipment, power unit, and engine to avoid fire hazard.
- Make sure all safety decals are installed. Replace if damaged. (See Safety Decals section for location.)
- Make sure shields and guards are properly installed and in good condition. Replace if damaged.
- Do not put this equipment into service unless all side skids are properly installed and in good condition. Replace if damaged.
- A minimum 20% of tractor and equipment weight must be on the tractor front wheels when attachments are in transport position. Without this weight, front tractor wheels could raise up resulting in loss of steering. The weight may be attained with front wheel weights, ballast in tires, front tractor weights or front loader. Weigh the tractor and equipment. Do not estimate.
- Inspect and clear area of stones, branches, or other hard objects that might be thrown, causing injury or damage.
- Connect PTO driveline directly to power unit PTO shaft. Never use adapter sleeves or adapter shafts. Adapters can cause driveline failures due to incorrect spline or incorrect operating length and can result in personal injury or death.

TRANSPORTATION

- Power unit must be equipped with Roll Over Protection System (ROPS) or ROPS cab and seat belt. Keep seat belt securely fastened. Falling off power unit can result in death from being run over or crushed. Keep foldable ROPS system in “locked up” position at all times.
- Always raise unit and install transport locks before transporting. Leak down or failure of mechanical or hydraulic system can cause equipment to drop.
- Always attach safety chain to tractor drawbar when transporting unit.
- Always comply with all state and local lighting and marking requirements. Turn on flashing warning lights whenever traveling on a public roadway.
- Never allow riders on power unit or attachment.
- Do not operate PTO during transport.
- Do not operate or transport on steep slopes. Refer to tractor manual for proper ballasting and slope recommendations.
- Do not operate or transport equipment while under the influence of alcohol or drugs.
- The maximum transport speed for this machine is 20 mph (30 km/h). Regardless of the maximum speed capability of the towing tractor, do not exceed the implement’s maximum transport speed. Doing so could result in:
 - Loss of control of the implement and tractor
 - Reduced or no ability to stop during braking
 - Implement tire failure
 - Damage to the implement or its components.
- Use additional caution and reduce speed when under adverse surface conditions, turning, or on inclines.
- Never tow this implement with a motor vehicle.

OPERATION

- Do not allow bystanders in the area when operating, attaching, removing, assembling, or servicing equipment.
- Never walk, stand, or place yourself or others under a raised wing or in the path of a lowering wing. Hydraulic system leak-down, hydraulic system failures, mechanical failures, or movement of control levers can cause wings to drop unexpectedly and cause severe injury or death.

(Safety Rules continued on next page)

SAFETY RULES



ATTENTION! BECOME ALERT! YOUR SAFETY IS INVOLVED!



(Safety Rules continued from previous page)

- Full chain shielding must be installed at all times. Thrown objects could injure people or damage property.
 - If the machine is not equipped with full chain shielding, operation must be stopped.
 - This shielding is designed to reduce the risk of thrown objects. The mower deck and protective devices cannot prevent all objects from escaping the blade enclosure in every mowing condition. It is possible for objects to ricochet and escape, traveling as much as 300 feet (92m).
- Never direct discharge toward people, animals, or property.
- Do not operate or transport equipment while under the influence of alcohol or drugs.
- Operate only in daylight or good artificial light.
- Keep hands, feet, hair, and clothing away from equipment while engine is running. Stay clear of all moving parts.
- Always comply with all state and local lighting and marking requirements.
- Never allow riders on power unit or attachment.
- Power unit must be equipped with ROPS or ROPS cab and seat belt. Keep seat belt securely fastened. Falling off power unit can result in death from being run over or crushed. Keep foldable ROPS system in “locked up” position at all times.
- Always sit in power unit seat when operating controls or starting engine. Securely fasten seat belt, place transmission in neutral, engage brake, and ensure all other controls are disengaged before starting power unit engine.
- Operate tractor PTO at 540 RPM (1000 RPM on Q Series cutters). Do not exceed.
- Raise or lower wings slowly to prevent personal injury or damage to cutter.
- Look down and to the rear and make sure area is clear before operating in reverse.
- Do not operate or transport on steep slopes.

- Do not stop, start, or change directions suddenly on slopes.
- Watch for hidden hazards on the terrain during operation.
- Stop power unit and equipment immediately upon striking an obstruction. Turn off engine, set parking brake, remove key, inspect, and repair any damage before resuming operation.
- Continuous operation while the clutch is slipping could cause heat build-up resulting in fire. Adjust slip clutch pressure by tightening springs to the dimension shown in the “Owner Service” section. If clutch is set to minimum spring length, replace the friction disks as shown.

MAINTENANCE

- Before cleaning, servicing, adjusting, repairing or unplugging, stop tractor engine, place all controls in neutral, set park brake, remove ignition key, and wait for all moving parts to stop.
- Before dismounting power unit or performing any service or maintenance, follow these steps: disengage power to equipment, lower the 3-point hitch and all raised components to the ground, operate valve levers to release any hydraulic pressure, set parking brake, stop engine, remove key, and unfasten seat belt.
- Do not modify or alter or permit anyone else to modify or alter the equipment or any of its components in any way.
- Your dealer can supply original equipment hydraulic accessories and repair parts. Substitute parts may not meet original equipment specifications and may be dangerous.
- To prevent contamination during maintenance and storage, clean and then cover hose ends, fittings, and hydraulic ports with tape.
- Do not allow bystanders in the area when operating, attaching, removing, assembling, or servicing equipment.

(Safety Rules continued on next page)

SAFETY RULES



ATTENTION! BECOME ALERT! YOUR SAFETY IS INVOLVED!



(Safety Rules continued from previous page)

- Never go underneath equipment (lowered to the ground or raised) unless it is properly blocked and secured. Never place any part of the body underneath equipment or between moveable parts even when the engine has been turned off. Hydraulic system leak down, hydraulic system failures, mechanical failures, or movement of control levers can cause equipment to drop or rotate unexpectedly and cause severe injury or death. Follow Operator's Manual instructions for working underneath and blocking requirements or have work done by an authorized dealer.
- Keep all persons away from operator control area while performing adjustments, service, or maintenance.
- Make certain all movement of equipment components has stopped before approaching for service.
- Frequently check blades. They should be sharp, free of nicks and cracks, and securely fastened.
- Do not handle blades with bare hands. Wear gloves. Careless or improper handling may result in injury.
- Your dealer can supply genuine replacement blades. Substitute blades may not meet original equipment specifications and may be dangerous.
- Tighten all bolts, nuts, and screws to torque chart specifications. Check that all cotter pins are installed securely to ensure equipment is in a safe condition before putting unit into service.
- Make sure all safety decals are installed. Replace if damaged. (See Safety Decals section for location.)
- Make sure shields and guards are properly installed and in good condition. Replace if damaged.
- Never perform cleaning, service or maintenance with engine running.
- Do not disconnect hydraulic lines until machine is securely blocked or placed in lowest position and system pressure is released by operating valve levers.

- Service and maintenance work not covered in OWNER SERVICE must be done by a qualified dealership. Special skills, tools, and safety procedures may be required. Failure to follow these instructions can result in serious injury or death.
- Explosive separation of tire and rim parts can cause serious injury or death. Release all air pressure before loosening bolts on wheel.

STORAGE

- Before disconnecting and storing, follow these instructions:
 - Store on level, solid ground.
 - Disconnect driveline and secure up off the ground.
 - Lower wings to ground.
 - Raise cutter center section and pin transport bar in raised position.
 - Attach parking jack and raise tongue weight off tractor drawbar.
 - Place wedge blocks at front and rear of wheels on center section and each wing to prevent wheel rotation.
 - Securely block all four corners of center section and each wing with jackstands.
 - Remove hydraulic hoses after tractor is turned off and all system pressure is released by operating valve levers several times.
 - Remove safety tow chain.
 - Remove retainer pin and high strength drawbar pin.
- Keep children and bystanders away from storage area.

SAFETY & INSTRUCTIONAL DECALS



ATTENTION! BECOME ALERT! YOUR SAFETY IS INVOLVED!



Replace Immediately If Damaged!

1 - Serial Number Plate

Model #
Serial #

(BAR CODE)

WOODS

Woods Equipment Company
Oregon, Illinois 61061 USA

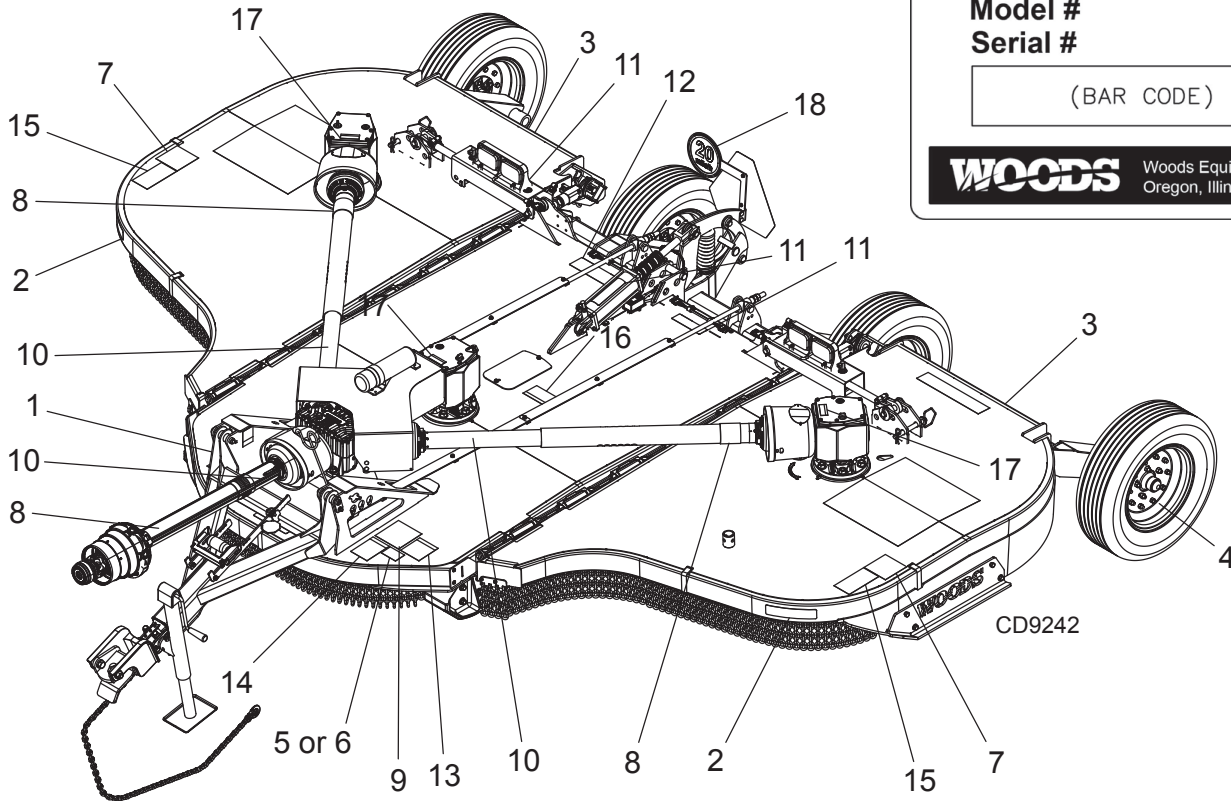

4 - PN 1006348 - Located on Wheel Rims

2 - FRONT AMBER REFLECTOR (PN 1002940)

3 - REAR RED REFLECTOR (PN 57123)

⚠ WARNING	EXPLOSION HAZARD
RELEASE ALL AIR PRESSURE BEFORE LOOSENING BOLTS. FAILURE TO DO SO COULD RESULT IN SERIOUS INJURY OR DEATH. MAX. SPEED: 20 MPH, MAX. WEIGHT: 4000 LBS., MAX. AIR PRESSURE: 40 PSI.	

BE CAREFUL!

Use a clean, damp cloth to clean safety decals.

Avoid spraying too close to decals when using a pressure washer; high-pressure water can enter through very small scratches or under edges of decals causing them to peel or come off.

Replacement safety decals can be ordered free from your Woods dealer. To locate your nearest dealer, check the Dealer Locator at www.WoodsEquipment.com, or in the United States and Canada call 1-800-319-6637.

SAFETY & INSTRUCTIONAL DECALS



ATTENTION! BECOME ALERT! YOUR SAFETY IS INVOLVED!



Replace Immediately If Damaged!

8 - PN 18864

⚠ DANGER



**ROTATING DRIVELINE CONTACT CAN CAUSE DEATH
KEEP AWAY!**

DO NOT OPERATE WITHOUT -

- All driveline guards, tractor and equipment shields in place.
- Drivelines securely attached at both ends.
- Driveline guards that turn freely on driveline.
- Read the operator's manual.
- Do not use PTO adapters.

18864

5 - PN 15922
(1000 RPM)

⚠ WARNING

DO NOT EXCEED PTO SPEED OF



- PTO speeds higher than 1000 RPM can cause equipment failure and personal injury.
- Tractor PTO master shield, PTO drive shaft guarding and PIC guards are to be kept in place.

15922

OR

6 - PN 18866
(540 RPM)

⚠ WARNING

DO NOT EXCEED PTO SPEED OF



- PTO speeds higher than 540 RPM can cause equipment failure and personal injury.
- Tractor PTO master shield, PTO drive shaft guarding and PIC guards are to be kept in place.

18866

7 - PN 15503

⚠ DANGER





ROTATING BLADES AND THROWN OBJECTS

- Do not put hands or feet under or into mower when engine is running.
- Before mowing, clear area of objects that may be thrown by blade.
- Keep bystanders away.
- Keep guards in place and in good condition.

BLADE CONTACT OR THROWN OBJECTS CAN CAUSE SERIOUS INJURY OR DEATH.

15503

9 - PN 18865

⚠ WARNING



FALLING OFF CAN RESULT IN BEING RUN OVER.

- Tractor must be equipped with ROPS (or ROPS CAB) and seat belt. Keep foldable ROPS systems in "locked up" position at all times.
- Buckle Up! Keep seat belt securely fastened.
- Never allow riders on mower or tractor.

RAISED EQUIPMENT CAN DROP AND CRUSH.

- Before working underneath, follow all instructions and safety rules in operator's manual and securely block up all corners of equipment with jack stands.
- Securely blocking prevents equipment dropping from hydraulic leak-down, hydraulic system failures or mechanical component failures.

FALLING OFF OR FAILING TO BLOCK SECURELY CAN RESULT IN SERIOUS INJURY OR DEATH.

18865

11 - PN W19924



⚠ WARNING

HIGH-PRESSURE HYDRAULIC OIL LEAKS CAN PENETRATE SKIN RESULTING IN SERIOUS INJURY, GANGRENE OR DEATH.

- Check for leaks with cardboard; never use hand.
- Before loosening fittings: lower load, release pressure, and be sure oil is cool.
- Consult physician immediately if skin penetration occurs.

W19924

17 - PN 1004114

⚠ DANGER

If shaft connection is visible, shield is missing. Replace shield before operating equipment.

1004114

SAFETY & INSTRUCTIONAL DECALS



ATTENTION! BECOME ALERT! YOUR SAFETY IS INVOLVED!



Replace Immediately If Damaged!

12 - PN 1045604

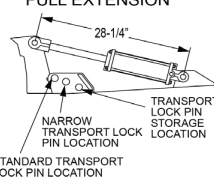
	⚠ WARNING	<p>TRANSPORT LOCK AND CYLINDER REQUIREMENTS</p> <p>SINGLE-ACTING FULL EXTENSION</p> 
	<p>RAISED IMPLEMENT CAN DROP AND CRUSH</p> <ul style="list-style-type: none"> Implement must be equipped with transport lock. Before working underneath, transport lock must be in the raised position. All corners of implement must be securely blocked with jackstands. All transport components must be functional, kept in good condition, and stored on equipment. Blocking up prevents implement dropping from hydraulic leak down, hydraulic system failures, or mechanical component failures. <p>FAILURE TO FOLLOW INSTRUCTIONS CAN RESULT IN SERIOUS INJURY OR DEATH.</p>	

10 - PN 33347

⚠ DANGER

<p>GUARD MISSING. DO NOT OPERATE.</p>
⚠ DANGER

<p>GUARD MISSING. DO NOT OPERATE.</p>
⚠ DANGER

13 - PN 1003751

⚠ WARNING

<p>CRUSHING AND PINCHING HAZARD</p> <ul style="list-style-type: none"> Be extremely careful handling various parts of the machine. They are heavy and hands, fingers, feet, and other body parts could be crushed or pinched between tractor and implement. Operate tractor controls from tractor seat only. Do not stand between tractor and implement when tractor is in gear. Make sure parking brake is engaged before going between tractor and implement. Stand clear of machine while in operation or when it is being raised or lowered. <p>FAILURE TO FOLLOW THESE INSTRUCTIONS COULD RESULT IN SERIOUS INJURY OR DEATH.</p>

14 - PN 18877

⚠ WARNING
<p>TO AVOID SERIOUS INJURY OR DEATH:</p> <ul style="list-style-type: none"> Read Operator's Manual (available from dealer) and follow all safety precautions. Keep all shields in place and in good condition. Operate mower from tractor seat only. Lower mower, stop engine and remove key before dismounting tractor. Allow no children or untrained persons to operate equipment. Do not transport towed or semi-mounted units over 25 mph (40 km/h). <p>FAILURE TO OPERATE SAFELY CAN RESULT IN INJURY OR DEATH.</p>

16 - PN 15502

⚠ WARNING
<p>ROTATING COMPONENTS</p> <p>Do not operate without cover in place. Look and listen for rotation. Do not open cover until all components have stopped.</p> <p>CONTACT WITH ROTATING PARTS CAN CAUSE SERIOUS INJURY.</p>

15 - PN 18964

⚠ DANGER	
	<p>RAISED WING EXPOSES BLADE AND INCREASES THROWN OBJECT HAZARDS.</p> <ul style="list-style-type: none"> Only raise for transport. Stop cutter and lock wing(s) up.
	<p>RAISED WING CAN FALL AND CRUSH.</p> <ul style="list-style-type: none"> Keep away. Lock up with wing transport bars. Lower wing(s) after transport and for storage
<p>FAILURE TO FOLLOW INSTRUCTIONS CAN RESULT IN SERIOUS INJURY OR DEATH.</p>	

18 - PN 611520



OPERATION

The designed and tested safety of this machine depends on it being operated within the limitations as explained in this manual. Be familiar with and follow all safety rules in the manual, on the cutter and on the tractor.

The safe operation of this cutter is the responsibility of the operator, who must be properly trained. The operator should be familiar with the equipment and all safety practices before starting operation. Read the safety information on page 7 through page 13.

Recommended tractor ground speed for most conditions is from 1 to 6 mph.

Always operate tractor PTO at 540 RPM on BW15.71 and BW10.71; on BW15.71Q and BW10.71Q operate PTO at 1000 RPM.

! DANGER

- Full chain shielding must be installed at all times. Thrown objects could injure people or damage property.
 - If the machine is not equipped with full chain shielding, operation must be stopped.
 - This shielding is designed to reduce the risk of thrown objects. The mower deck and protective devices cannot prevent all objects from escaping the blade enclosure in every mowing condition. It is possible for objects to ricochet and escape, traveling as much as 300 feet (92m).

! WARNING

- Never allow children or untrained persons to operate equipment.
- Do not allow bystanders in the area when operating, attaching, removing, assembling, or servicing equipment.
- Make sure spring-activated locking pin or collar slides freely and is seated firmly in tractor PTO spline groove.

! CAUTION

- Stop power unit and equipment immediately upon striking an obstruction. Turn off engine, remove key, inspect, and repair any damage before resuming operation.
- Always wear relatively tight and belted clothing to avoid entanglement in moving parts. Wear sturdy, rough-soled work shoes and protective equipment for eyes, hair, hands, hearing, and head; and respirator or filter mask where appropriate.

CONNECTING CUTTER TO TRACTOR

NOTICE

- For tractors with a 1-3/8" diameter PTO shaft, the horizontal distance from the end of the tractor PTO shaft to the center of drawbar pin should be 14" for 540 RPM cutter and 16" for the 1000 RPM cutters. This will minimize joint knock and damage to drive components.

Use of the CV Lift Assist System

The Batwing® cutter has a system to help lift and support the driveline while connecting and disconnecting it from the tractor. Follow the instructions below.

1. Remove klik pin.
2. Lift lever to vertical position which will lift driveline.
3. Connect coupler to tractor PTO shaft.
4. Lower lever and secure with klik pin.

If the driveline is held too high or low, the roller carriage can be adjusted by removing the mounting bolts, moving it to the preferred position, and replacing the bolts.

NOTICE

Do not operate with CV lift in the raised position.

If the tractor used to power the Batwing® has a PTO shaft and drawbar closer than the current standards, the driveline could contact the lift assist frame or roller during use and could cause damage and failure to the driveline. When using a tractor of this type, the CV lift assist system should be removed from the tongue to avoid potential contact and damage.

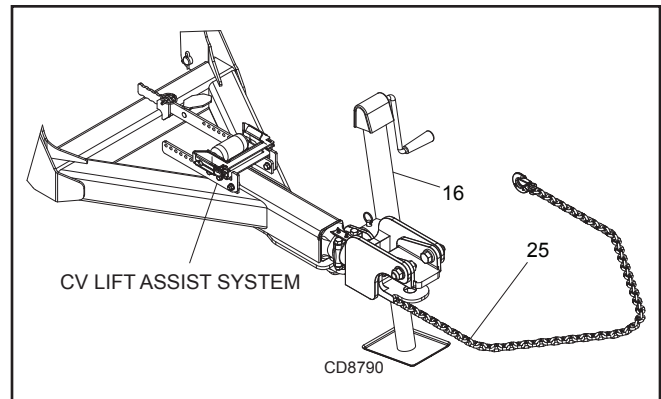

Figure 1. Cutter to Tractor Connection

Mechanical Connection

(Figure 1)

1. Attach cutter using a 1-1/8" clevis pin and clip.
2. Attach safety tow chain (25) to drawbar support. Leave enough slack for turning.
3. Connect cutter driveline to tractor PTO shaft, making sure the spring-activated lock pin slides freely and is seated in tractor PTO splined groove.
4. Attach driveline shield tether chain to tractor drawbar to prevent rotation, if provided.

NOTE: CV driveline does not require a tether chain.

5. Loosen bolts in jack mount. Adjust jack so foot plate sits flat for storage. Tighten bolts.
6. Remove parking jack (16) from the tongue and attach it to the storage post on the front of the left wing.

Hydraulic Connection

1. Inspect hydraulic hoses to ensure they are in good condition.
2. Clean the fittings before connecting them to the tractor hydraulic ports.
3. Route the hose through the hose holder at the hitch and be sure the hose can slide freely in the holder. Do not allow hose slack to drag on the ground or become caught on tractor protrusions.
4. Attach the hydraulic hose to the tractor.
5. From the operator position, start tractor and raise and lower deck several times to purge trapped air from the hydraulic cylinder.

Interference Check

1. Be sure that tractor 3-point lift links do not interfere with hydraulic hoses, cutter driveline, or cutter frame.
2. Check for straight-ahead operation and at full turning angles. If there is any interference, remove the lower lift links.
3. Contact between tractor lift links and cutter parts can cause damage, especially when turning.

CV Driveline Turning Limits

NOTICE

- **You must not exceed a turning angle of 80 degrees at the head of the Constant Velocity driveline or damage will occur.**

NOTE: Remove CV drive shipping bracket before operation and discard. This bracket is only supplied on factory assembled units with a CV drive installed.

1. To check for potential excessive turn angle, disconnect the driveline from tractor.
2. Start engine and turn as far right or left as possible.
3. Shut engine off and try to connect CV driveline to tractor. If it cannot be connected, the turn angle is too severe.
4. Restart engine and straighten angle slightly, shut off engine and try to connect CV driveline to tractor.
5. Repeat the process until the driveline can be connected. The point at which the driveline can be connected is the maximum turn that should be made.

Cutting Height Adjustment

NOTICE

- **Avoid ground contact with blades. Striking ground with blades produces one of the most damaging shock loads a cutter can encounter. If this occurs repeatedly, the cutter, driveline, and gearboxes will be damaged.**

Cutting height range is from 1" to 15". A hydraulic cylinder is used for cutting height adjustment.

When selecting a cutting height, you should consider the area of operation. If the ground is rolling and has mounds the blades could contact, set the cutting height accordingly. The cutting height (blade edge) is approximately 1" above the bottom of the side skid.

Cutting Height (Normal Mowing) - Center Section

1. Position the cutter on a hard level surface and select an approximate cutting height, example 6".
2. Raise wings and lock them in the UP position.
3. Raise or lower the center section to obtain a distance of 5" from bottom edge of skid shoe to the ground.
4. Loosen jam nuts on the attitude rod that runs from the wheel yoke to the tongue.
5. Adjust rod in or out until the rear of the cutter is approximately 1/2" higher than the front.
6. Tighten jam nuts against sleeve.

Cutting Height (Normal Mowing) - Wings

1. Lower wings to normal mowing position.
2. Loosen the jam nut on the adjustable link (turn buckle).
3. Lengthening the link will raise the wing, shortening the link will lower the wing. The rear edge of the wing should be parallel to the ground.

When using the cutter to shred, the rear of the cutter deck should be approximately 1/2" to 1" lower than the front.

TRACTOR OPERATION

Use care when operating around tree limbs and other low objects. Avoid being knocked off tractor and being injured.

Only use a tractor with a Roll Over Protection Structure (ROPS) and seat belt. Securely fasten seat belt.

The cutter is operated with tractor controls. Engage the PTO at a low RPM to prevent excessive loads on the cutter drive system. Increase throttle to recommended PTO operating RPM.

Be sure operator is familiar with all controls and can stop tractor and cutter quickly in an emergency. The operator should give complete, undivided attention to operating tractor and cutter.

CUTTER OPERATION

When beginning operation of the cutter, make sure that all persons are in a safe location.

Power for operating the cutter is supplied by the tractor PTO. Operate PTO at 540 (1000 RPM for "Q" models).

Know how to stop the tractor and cutter quickly in an emergency.

Engage PTO at a low engine, RPM to minimize stress on the drive system and gearbox.

With PTO engaged, raise PTO speed to 540 or 1000 RPM depending on model and maintain throughout cutting operation.

Gearbox protection is provided by a slip clutch with replacement fiber disc. The slip clutch is designed to slip when excessive torsional loads occur.

Move slowly into material. Adjust tractor ground speed to provide a clean cut without lugging the tractor engine.

Use a slow ground speed for better shredding.

Proper ground speed will depend on the terrain and the material's height, type, and density.

Normally, ground speed will range from 1 to 6 mph. Tall, dense material should be cut at a low speed; thin, medium-height material can be cut at a faster ground speed.

Always operate tractor PTO at proper RPM (540 or 1000 depending on model) to maintain blade speed and to produce a clean cut.

Under certain conditions tractor tires may roll down some grass and prevent cutting at the same height as the surrounding area. When this occurs, reduce your ground speed but maintain PTO at 540 or 1000 RPM. The lower ground speed will permit grass to rebound partially.

Mowing Tips

WARNING

- **Look down and to the rear and make sure area is clear before operating in reverse.**
- **Do not operate or transport on steep slopes.**
- **Do not stop, start, or change directions suddenly on slopes.**
- **Use extreme care and reduce ground speed on slopes and rough terrain.**
- **Watch for hidden hazards on the terrain during operation.**

CAUTION

- **Stop power unit and equipment immediately upon striking an obstruction. Turn off engine, remove key, inspect, and repair any damage before resuming operation.**

Maximum recommended ground speed for cutting or shredding is 6 miles per hour. Adjust tractor ground speed by using higher or lower gears to provide a clean cut without lugging tractor engine.

Tall material should be cut twice. Cut material higher the first pass. Cut at desired height at 90 degrees the second pass.

Remember, sharp blades produce cleaner cuts and use less power.

Before entering an area, analyze it to determine the best procedure. Consider the height and type of material to be cut and the terrain type (hilly, level or rough, etc.).

Shredding

The cutter may be used to shred various crops including green manure, straw, stubble, asparagus residue, corn stalks and similar crops in preparation for tilling. It may also be used to shred pruning in orchards, groves and vineyards.

Each shredding operation may require a different set-up. Start with front edge of cutter high. Adjust up or down as necessary with attitude rod. Experiment until you obtain the results you want.

When shredding attitude is set, check that the distance from the bottom rear edge of the wing to the ground matches the bottom edge of the rear center section to the ground.

TRANSPORTING

⚠ WARNING

- Power unit must be equipped with Roll Over Protection System (ROPS) or ROPS cab and seat belt. Keep seat belt securely fastened. Falling off power unit can result in death from being run over or crushed. Keep foldable ROPS system in “locked up” position at all times.
- Always raise unit and install transport locks before transporting. Leak down or failure of mechanical or hydraulic system can cause equipment to drop.
- Always attach safety chain to tractor drawbar when transporting unit.
- Never exceed 20 mph (32.2 km/h) during transport.
- Never allow riders on power unit or attachment.
- Do not operate PTO during transport.
- Do not operate or transport on steep slopes. Refer to tractor manual for proper ballasting and slope recommendations.
- Do not operate or transport equipment while under the influence of alcohol or drugs.

⚠ CAUTION

- Always comply with all state and local lighting and marking requirements. Turn on flashing warning lights whenever traveling on a public roadway.

Lock-Up

Always transport with wings and center frame in the raised, locked position.

Wing Lock-Up

1. Raise wing to the up position.
2. Remove klik pin and lock pin from storage position.
3. Place lock pin in lock position and secure with klik pin.
4. Repeat steps 1 to 3 for opposite wing.
5. Lower cylinder against lock-up bars (Figure 2).

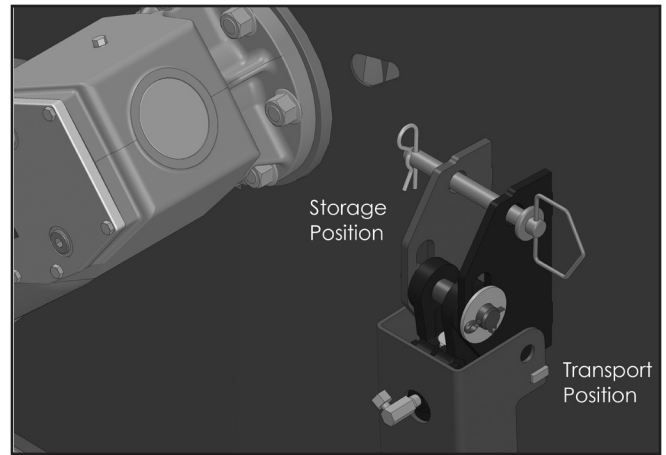

Figure 2. Transport Lock Pin

Center Section Lock-Up

1. Raise cutter with hydraulic cylinder to maximum height.
2. Remove klik pin and lock pin from storage position (Figure 3).

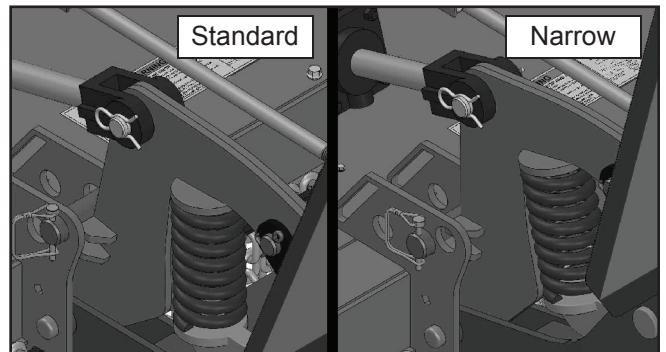

Figure 3. Transport Lock Pin in Standard & Narrow Width Positions

3. Place lock pin and klik pin in lock position and lower cutter against lock pin.
4. For width transport less than 10 feet, place lock pin in narrow transport position. See Figure 3.
5. To lower cutter for operation, extend hydraulic cylinder to raise cutter. Move lock pin from lock position to storage position (Figure 4).
6. Lower cutter to desired cutting height.

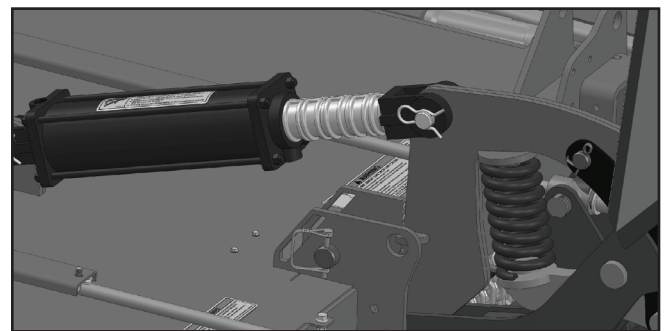

Figure 4. Transport Lock Pin In Operation Position

STORAGE

Follow these steps when storing your cutter:

1. Clean cutter before storing. See page 23 for cleaning instructions. Store on level, solid ground.
2. Disconnect driveline and secure up off the ground.
3. Lower wings to ground.
4. Raise cutter center section and pin transport bar in raised position.
5. Attach parking jack and raise tongue weight off tractor drawbar.
6. Place wedge blocks at front and rear of wheels on center section and each wing to prevent wheel rotation.
7. Securely block all four corners of center section and each wing with jack stands.
8. Remove hydraulic hoses after tractor is turned off and all system pressure is released by operating valve levers several times.
9. Remove safety tow chain.
10. Remove retainer pin and high strength drawbar pin.
11. Keep children and bystanders away from storage area.

PRE-OPERATION CHECKLIST

(OWNER'S RESPONSIBILITY)

- _____ Review and follow all safety rules and safety decal instructions on page 7 through page 13.
- _____ Check that all safety decals are installed and in good condition. Replace if damaged.
- _____ Check that equipment is properly and securely attached to tractor.
- _____ Make sure driveline spring-activated locking pin or collar slides freely and is seated firmly in tractor PTO spline groove.
- _____ Check all lubrication points and grease as instructed in lubrication information. Make sure the PTO slip joint is lubricated and that the gearbox fluid levels are correct.
- _____ Set tractor PTO at correct RPM for your equipment.
- _____ Lubricate all grease fitting locations. Make sure PTO shaft slip joint is lubricated.
- _____ Check that all hydraulic hoses and fittings are in good condition and not leaking before starting tractor. Check that hoses are not twisted, bent sharply, kinked, frayed, or pulled tight. Replace any damaged hoses immediately.
- _____ Check that all hardware is properly installed and secured.
- _____ Check cutting height and attitude adjustment.
- _____ Raise and lower equipment to make sure air is purged from hydraulic cylinders and hoses.
- _____ Check that blades are sharp and secure and cutting edge is positioned to lead in a counter clockwise rotation for center and right wings, and clockwise for left wing.
- _____ Make sure tractor ROPS or ROPS cab and seat belt are in good condition. Keep seat belt securely fastened during operation.
- _____ Check that shields and guards are properly installed and in good condition. Replace if damaged.
- _____ Before starting engine, operator must be in tractor seat with seat belt fastened. Place transmission in neutral or park, engage brake and disengage tractor PTO.
- _____ Inspect area to be cut and remove stones, branches, or other hard objects that might be thrown and cause injury or damage.
- _____ Inspect rubber or chain shielding and replace any damaged rubber shield or missing links.
- _____ Make sure tractor 3-point lift links do not interfere with hydraulic hoses or driveline throughout full turning range.

OWNER SERVICE

The information in this section is written for operators who possess basic mechanical skills. If you need help, your dealer has trained service technicians available. For your protection, read and follow the safety information in this manual.

WARNING

- Keep all persons away from operator control area while performing adjustments, service, or maintenance.
- Before working underneath, disconnect driveline from tractor, lower wings to ground, raise cutter, and pin transport bar in raised position. Attach parking jack and lower to ground. Securely block all four corners of center section and each wing with jack stands. Blocking up prevents the cutter from dropping due to hydraulic leak down, hydraulic system failure, or mechanical component failure.
- Service and maintenance work not covered in OWNER SERVICE must be done by a qualified dealership. Special skills, tools, and safety procedures may be required. Failure to follow these instructions can result in serious injury or death.
- Before cleaning, servicing, adjusting, repairing or unplugging, stop tractor engine, place all controls in neutral, set park brake, remove ignition key, and wait for all moving parts to stop.
- Never perform cleaning, service or maintenance with engine running.

CAUTION

- If you do not understand any part of this manual and need assistance, see your dealer.
- Always wear relatively tight and belted clothing to avoid entanglement in moving parts. Wear sturdy, rough-soled work shoes and protective equipment for eyes, hair, hands, hearing, and head; and respirator or filter mask where appropriate.

BLOCKING METHOD

To minimize the potential hazards of working underneath the cutter, follow these procedures:

WARNING

- Before performing any service or maintenance, lower equipment to ground or block securely, turn off engine, remove key, and disconnect driveline from tractor PTO.
- Never go underneath equipment (lowered to the ground or raised) unless it is properly blocked and secured. Never place any part of the body underneath equipment or between moveable parts even when the engine has been turned off. Hydraulic system leak down, hydraulic system failures, mechanical failures, or movement of control levers can cause equipment to drop or rotate unexpectedly and cause severe injury or death. Follow Operator's Manual instructions for working underneath and blocking requirements or have work done by a qualified dealer.

Do not position jackstands under wheels, axles, or wheel supports. Components can rotate and cause cutter to fall.

1. Jackstands with a load rating of 1000 lbs. or more are the only approved blocking device for this cutter. Install jackstands (shown by Xs in Figure 5) under the cutter before working underneath unit.
2. Consider the overall stability of the blocked unit. Just placing jackstands underneath will not ensure your safety.

The working surface must be level and solid to support the weight on the jackstands. Make sure jackstands are stable, both top and bottom. Make sure cutter is approximately level.

3. With full cutter weight lowered onto jackstands, test blocking stability before working underneath.
4. If cutter is attached to tractor when blocking, set the brakes, remove key, and block cutter before working underneath.
5. Securely block rear tractor wheels, in front and behind.

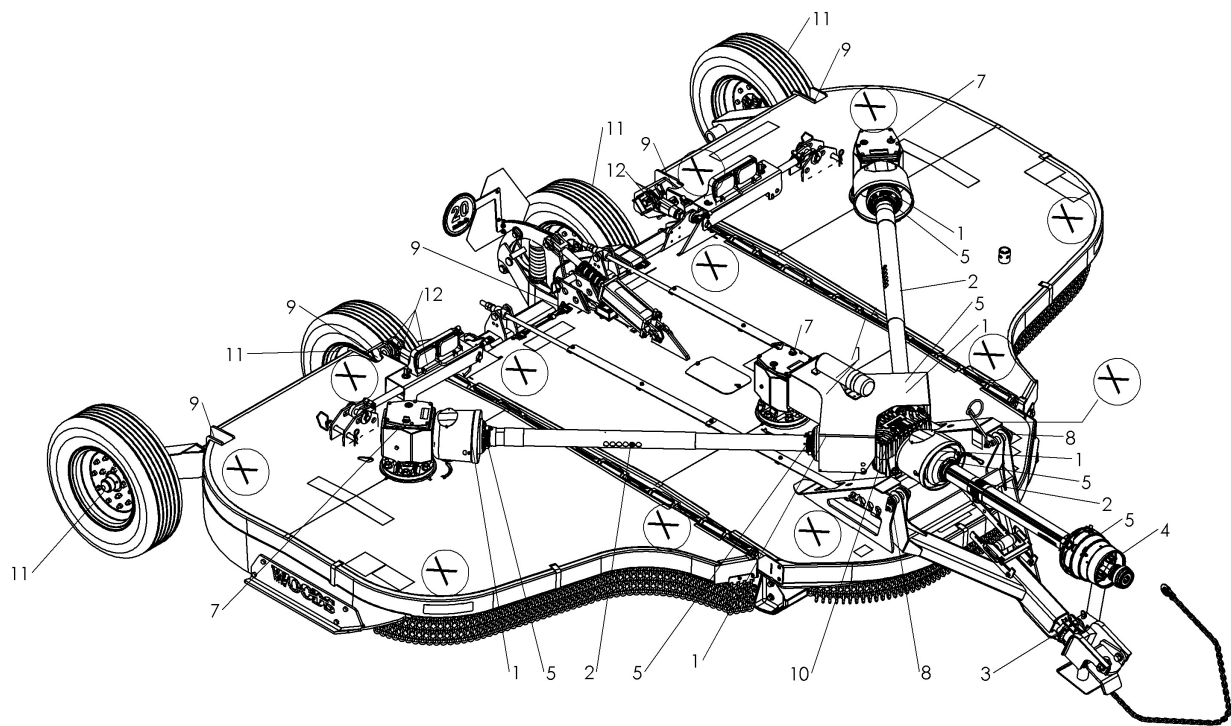

1	Driveline U-joint	10 Hours	8	Tongue pivot (2)	40 Hours
2	Telescoping shaft	10 Hours	9	Wheel yoke pivot (7)	40 Hours
3	Clevis pivot	40 Hours	10	Gearbox (bottom of side hole)	Daily
4	CV body assembly (10 pumps minimum)	10 Hours	11	Tailwheel spindle	20 Hours
5	Driveline shield	10 Hours	12	Turnbuckle	40 Hours
7	Gearbox (above lower line on dipstick)	Daily	13	Blade pin	40 Hours

Figure 5. Jackstand Placement and Lubrication Points

LUBRICATION

Do not let excess grease collect on or around parts, particularly when operating in sandy areas.

See Figure 5 for lubrication points and frequency or lubrication based on normal operating conditions. Severe or unusual conditions may require more frequent lubrication.

Use a lithium grease of #2 consistency with a MOLY (molybdenum disulfide) additive for all locations unless otherwise noted. Be sure to clean fittings thoroughly before attaching grease gun. One good pump of most guns is sufficient when the lubrication schedule is followed.

Gearbox Lubrication

For gearbox, use a high quality gear oil with a viscosity index of 80W or 90W and an API service rating of

GL-4 or -5 in gearboxes. Fill gearbox until oil is above lower line on dipstick. Check gearbox oil level daily for evidence of leakage, and contact your dealer if leakage occurs. Check vent plug periodically and clean if it does not relieve pressure.

Driveline Lubrication

1. Lubricate the driveline slip joint every eight operating hours. Failure to maintain proper lubrication could result in damage to U-joints, gearbox, and driveline.
2. Lower cutter to ground, disconnect driveline from tractor PTO shaft, and slide halves apart but do not disconnect from each other.
3. Apply a bead of grease completely around male half where it meets female half. Slide drive halves over each other several times to distribute grease.

Seasonal Lubrication

In addition to the daily recommended lubrication, a more extensive application is recommended seasonally.

1. Fill CV double yokes with 20 pumps of grease with the joints in a straight line.
2. Articulate CV body to maximum angle several times to ensure full coverage of joints.
3. Place joints in the straight position and add 10 additional pumps of grease to both joints.
4. Wipe telescoping drive clean of all old grease and contaminants.
5. Add a thin layer of new grease over telescoping drive.

BLADES

⚠ WARNING

- Before working underneath, read manual instructions, securely block up, and check stability. Secure blocking prevents equipment from dropping due to hydraulic leak down, hydraulic system failure, or mechanical component failure.

Blade Removal (Figure 6)

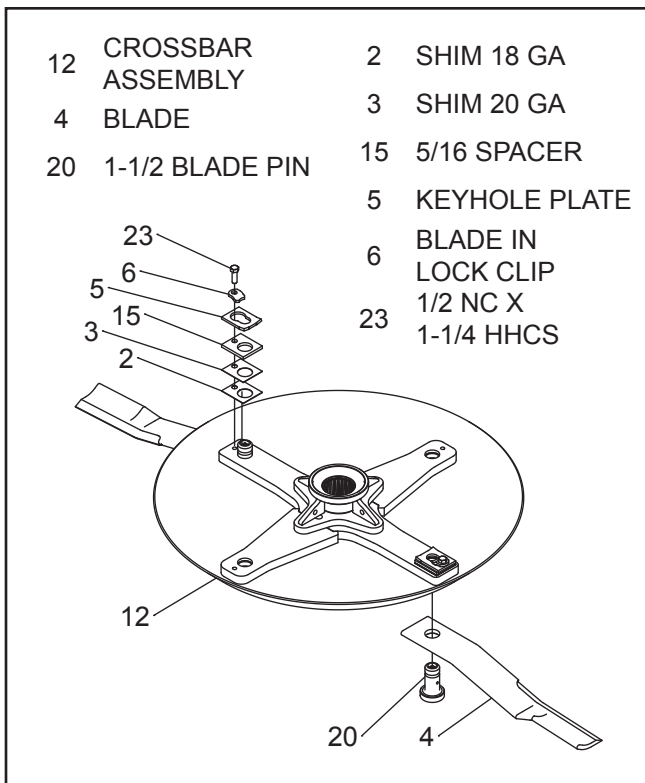

Figure 6. Blade Assembly

1. Disconnect driveline from tractor PTO.
2. Raise cutter and block securely (see Figure 5).

3. Align crossbar (12) with blade access hole in the cutter frame. Remove cap screw (23), blade pin lock clip (6), keyhole plate (5), spacer (15), and shims (2 & 3). Carefully drive blade pin (20) out of crossbar.
4. Rotate crossbar and repeat for opposite blade.

NOTICE

- If blade pin (20) is seized in crossbar and extreme force will be needed to remove it, support crossbar from below to prevent gearbox damage.

Blade Installation (Figure 6)

⚠ CAUTION

- Your dealer can supply genuine replacement blades. Substitute blades may not meet original equipment specifications and may be dangerous.
- Crossbar rotation has clockwise rotation on left gearbox and counterclockwise rotation on the right and center gearboxes when looking down on cutter. Be sure to install blade cutting edge to lead in correct rotation.

NOTE: Always replace or sharpen both blades at the same time.

1. Inspect blade pin (20) for nicks or gouges, and if you find any replace the blade pin.
2. Insert blade pin through the blade. Blade should swivel on blade pin; if it doesn't, determine the cause and correct.
3. Align crossbar (12) with blade access hole in cutter frame. Make sure blade offset is down away from cutter.
4. Insert blade pin (20) through blade. Push blade pin through crossbar.
5. Install shims (2 & 3) and spacer (15) over blade pin.
NOTE: Only use enough shims to allow keyhole plate (5) to slide into blade pin groove.
6. Install blade clip (6) over keyhole plate and into blade pin groove.
7. Secure into position with cap screw (23). Torque cap screw to 85 lbs-ft.
8. Grease pin via zerk at end of pin.
9. Repeat steps for opposite side.

NOTE: Blade should be snug but should swivel on pin without having to exert excessive force. Blade should not move more than a 1/4 inch up or down at the tip. Keep any spacers not used in the installation as replacements or for future installation.

Blade Sharpening

NOTICE

- When sharpening blades, grind the same amount on each blade to maintain balance. Replace blades in pairs. Unbalanced blades will cause excessive vibration, which can damage gearbox bearings. Vibration may also cause structural cracks to cutter.
1. Sharpen both blades at the same time to maintain balance. Follow original sharpening pattern.
 2. Do not sharpen blade to a razor edge—leave at least a 1/16" blunt edge.
 3. Do not sharpen back side of blade.

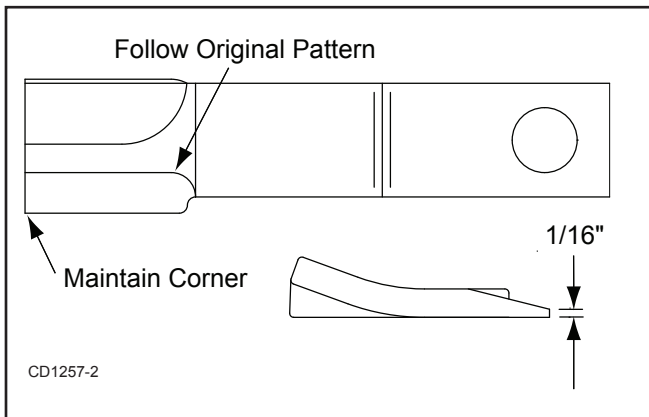

Figure 7. Blade Sharpening

SLIP CLUTCH ADJUSTMENT

(FIGURE 8)

The slip clutch is designed to slip so that the gearbox and driveline are protected if the cutter strikes an obstruction.

A new slip clutch or one that has been in storage over the winter may seize. Before operating the cutter, make sure it will slip by performing the following operation:

1. Turn off tractor engine and remove key.
2. Tighten four nuts (12) to remove pressure from the clutch plates (2). Repeat for all three clutches.
3. Start tractor at low throttle and slowly engage PTO and allow clutches to slip for 5 seconds. Disengage PTO and turn off tractor engine.
4. If clutches slip freely, completely loosen nuts (12).
5. If clutch does not slip freely, disassemble and clean plates (4, 6, & 7), flange yoke (1), and clutch hub (3).
6. Reassemble clutch.
7. Tighten Belleville spring (5) with nuts (11) until it is against the thrust plate (4) of the clutch. Back off each of the four nuts (11) until gap between Belleville spring and thrust plate is .236" as shown in Figure 7.
8. If a clutch continues to slip when the spring is compressed to .236" gap, check friction discs (2) for excessive wear. Discs are 1/8" when new. Replace discs after 1/16" wear. Minimum disc thickness is 1/16".

NOTE: When storing cutter for long periods of time, relieve the pressure on the clutch discs by tightening the four nuts (12) on each clutch. Completely loosen nuts (12) to return to service.

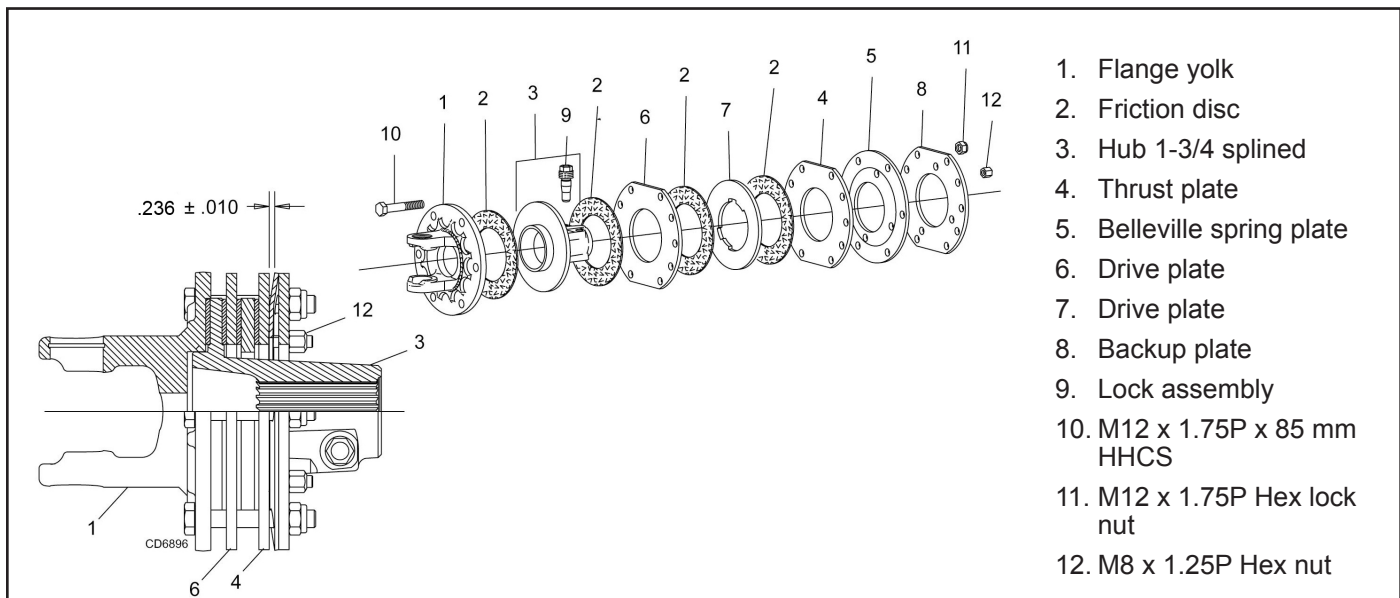

Figure 8. Slip Clutch Assembly

SHIELDING REPAIR

! DANGER

- Full chain shielding must be installed at all times. Thrown objects could injure people or damage property.
 - If the machine is not equipped with full chain shielding, operation must be stopped.
 - This shielding is designed to reduce the risk of thrown objects. The mower deck and protective devices cannot prevent all objects from escaping the blade enclosure in every mowing condition. It is possible for objects to ricochet and escape, traveling as much as 300 feet (92m).

Repairing Chain Shielding

1. Inspect chain shielding each day of operation and replace any broken or missing chains as required.
2. Replace any missing hardware.

SERVICING TIRES SAFELY

Used Aircraft Tires (Figure 9)

! WARNING



- Explosive separation of tire and rim parts can cause serious injury or death. Release all air pressure before loosening bolts.

Do not attempt to mount a tire unless you have the proper equipment and experience to perform the job.

Always maintain the correct tire pressure. Do not inflate tires above the recommended pressure. Never weld or heat a wheel and tire assembly. The heat can cause an increase in air pressure and result in a tire explosion. Welding can structurally weaken or deform the wheel.

When inflating tires, use a clip-on chuck and an extension hose long enough to allow you to stand to the side — not in front of or over the tire assembly. Use a safety cage if available.

Check wheels for low pressure, cuts, bubbles, damaged rims, or missing lug bolts and nuts.

Never remove split rim assembly hardware (A) with the tire inflated.

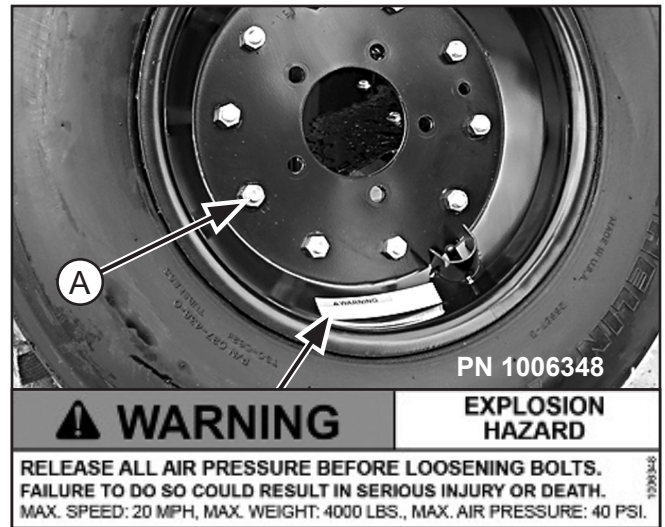

Figure 9. Split Rim Tire Servicing

CLEANING

After Each Use

- Remove large debris such as clumps of dirt, grass, crop residue, etc. from machine.
- Inspect machine and replace worn or damaged parts.
- Replace any safety decals that are missing or not readable (supplied free by your Woods dealer).

Periodically or Before Extended Storage

- Clean large debris such as clumps of dirt, grass, crop residue, etc. from machine.
 - Remove the remainder using a low-pressure water spray.
1. Be careful when spraying near scratched or torn safety decals or near edges of decals as water spray can peel decal off surface.
 2. Be careful when spraying near chipped or scratched paint as water spray can lift paint.
 3. If a pressure washer is used, follow the advice of the pressure washer manufacturer.
- Inspect machine and replace worn or damaged parts.
 - Sand down scratches and the edges of areas of missing paint and coat with Woods spray paint of matching color (purchase from your Woods dealer).
 - Replace any safety decals that are missing or not readable (supplied free by your Woods dealer). See Safety & Instructional Decals section for location drawing.

TROUBLESHOOTING

PROBLEM	POSSIBLE CAUSE	SOLUTION
Does not cut	Dull blades Worn or broken blades Incorrect PTO speed Ground speed too fast Drive not functioning (blades do not turn when PTO is running) Gearbox malfunction Excessive clutch slippage Incorrect blade direction	Sharpen blades. Replace blades. (Replace in pairs only.) Set at rated PTO speed. Reduce ground speed. Check drive shaft connection. Check gearbox. Repair gearbox. Adjust clutch. Check to be sure blade edge is correct for direction of rotation.
Streaks or ragged cut	Broken or worn blades Attitude incorrect Ground speed too fast Excessive cutting height Excessive lush and tall vegetation	Replace or sharpen blades. Level machine. Reduce ground speed. Lower cutting height. (Note: Set height so blades do not frequently hit ground.) Recut at 90° to first pass.
Excessive side skid wear	Running with skids continuously on ground	Raise cutting height or adjust.
Excessive clutch slippage	Clutch out of adjustment Clutch discs worn; wear stops contacting opposite plate Blades hitting ground	Adjust clutch. Replace discs. Raise cutting height.
Vibration	Broken blade Bearing failure Hitch length incorrect Universal drive	Replace blades in pairs. Check gearbox shafts for side play. Reset hitch length. Adjust pedestal bearing height to be parallel to ground.
Blades hitting deck	Bent blades or crossbar	Replace bent blades or crossbar.
Unit will not raise	Low oil	Add hydraulic oil.
Unit doesn't cut level	Wing section cuts lower than center Wing section cuts higher than center	Lengthen turnbuckle connecting center yoke to wing wheel yoke. Shorten turnbuckle connecting center yoke to wing wheel yoke.

DEALER SERVICE

The information in this section is written for dealer service personnel. The repair described here requires special skills and tools. If your shop is not properly equipped or your mechanics are not properly trained in this type of repair, you may be time and money ahead to replace complete assemblies.

⚠ WARNING

- Before working underneath, read manual instructions, securely block up, and check stability. Secure blocking prevents equipment from dropping due to hydraulic leak down, hydraulic system failure, or mechanical component failure.
- Keep all persons away from operator control area while performing adjustments, service, or maintenance.

⚠ CAUTION

- Always wear relatively tight and belted clothing to avoid getting caught in moving parts. Wear sturdy, rough-soled work shoes and protective equipment for eyes, hair, hands, hearing, and head; and respirator or filter mask where appropriate.

GEARBOX MAINTENANCE

NOTE: Read this entire section before starting any repair. Many steps are dependent on each other.

1. Fill gearbox with SAE 80W or 90W gear lube. Proper oil level is between lowest ring and end of dipstick.

NOTE: Repair to this gearbox is limited to replacing bearings, seals, and gaskets. Replacing gears, shafts, and a housing is not cost effective. Purchasing a complete gearbox is more economical.

2. Inspect gearbox for leakage and bad bearings. Leakage is a very serious problem and must be corrected immediately.

NOTE: Bearing failure is indicated by excessive noise and side-to-side or end-play in gear shafts.

Seal Replacement (Figure 10)

Recommended sealant for gearbox repair is Permatex® Aviation 3D Form-A-Gasket or equivalent.

Leakage can occur at the vertical or horizontal gaskets and shaft seals.

Leakage at the horizontal gasket or seal can be repaired without removing the gearbox from the cutter.

Seal Installation

NOTE: Proper seal installation is important. An improperly installed seal will leak.

1. Clean area in housing where seal outer diameter (OD) seats. Apply a thin coat of Permatex.
2. Inspect area of shaft where seal seats. Remove any burrs or nicks with an emery cloth.
3. Lubricate gear shaft and seal lips.
4. Place seal squarely on housing, spring-loaded lip toward housing. Select a piece of pipe or tubing with an OD that will sit on the outside edge of the seal but will clear the housing. Tubing with an OD that is too small will bow seal cage and ruin seal.
5. Carefully press seal into housing, avoiding distortion to the metal seal cage.

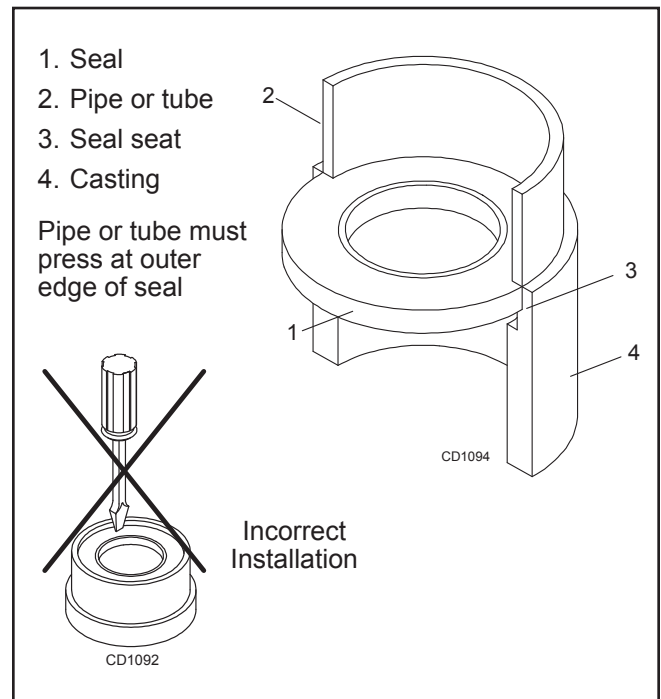

Figure 10. Seal Installation

Vertical Shaft Seal Replacement (Figure 11)

1. Disconnect and remove the rear driveline from the gearbox.
2. Remove drain plug and drain gear lube from housing. Replace plug when empty.
3. Remove crossbar (see page 30).
4. Remove protective seal (8) and vertical shaft seal (18). Replace seal (18) with new seal.

Vertical seal should be recessed in housing. Horizontal seal (19) should be pressed flush with out-side of housing.

NOTE: Distortion to seal cage or damage to seal lip will cause seal to leak.

5. Fill gearbox with SAE 80W or 90W gear lube until it runs out the level plug.
6. Remove and replace any seal damaged in installation.

Horizontal Shaft Seal Replacement (Figure 11)

1. Disconnect and remove the rear driveline from the gearbox.
2. Remove drain plug and drain gear lube from housing. Replace plug when empty.
3. If the leak occurred at either end of horizontal shaft, remove oil cap (20) and/or oil seal (19). Replace with new one.
4. Fill gearbox with SAE 80W or 90W gear lube to proper level.

GEARBOX REPAIR

Removal from Cutter (Figure 11)

NOTE: Gearbox is heavy: do not attempt to move without mechanical assistance.

1. Disconnect and remove the rear driveline from the gearbox.
2. Remove cotter pin and nut from vertical shaft and remove crossbar (see page 30).
3. Remove the six bolts that attach gearbox to cutter and remove gearbox.

Disassembly (Figure 11)

1. Remove top cover (22) from gearbox and pour out gear oil.
2. Remove oil cap (20) (to be replaced).
3. Remove snap ring (10) and shim (13) from input shaft (3).
4. Support gearbox in hand press and push on input shaft (3) to remove bearing (7).

5. Remove six cap screws (23) and top cover (22) from housing. Remove gear (1) from inside housing.
6. Remove oil seal (19) from front of housing (to be replaced).
7. Remove snap ring (10) and shim (13) from front of housing (2).
8. Remove input bearing (7) by using a punch and hammer from outside of housing.
9. Support housing in vise in a horizontal position.
10. The castle nut (15), cotter pin (25), and hub are already removed with the stump jumper/crossbar. Remove the protective seal (8), and oil seal (18).
11. Remove cotter pin (9), castle nut (14), and shim (17) from output shaft (4).
12. Remove output shaft (4) by using a punch and hammer and tap on top to drive down. Remove gear (5) and shim (16) from inside housing.
13. Remove bottom bearing (26) by using a punch and hammer from the top, outside the housing.
14. Support housing upside down (top cover surface) and remove bottom bearing (6) by using a punch and hammer from the bottom side of the housing.
15. Inspect gears for broken teeth and wear. Some wear is normal and will show on loaded side. Forged gear surfaces are rough when new. Check that wear pattern is smooth.
16. Inspect vertical and horizontal shafts for grooves, nicks, or bumps in the areas where the seals seat. Resurface any damage with emery cloth.
17. Inspect housing and caps for cracks or other damage.

Assembly (Figure 11)

1. Clean housing, paying specific attention to areas where gaskets will be installed.
2. Wash housing and all components thoroughly. Select a clean area for gearbox assembly. Replace all seals, bearings, and gaskets. All parts must be clean and lightly oiled before reassembling.
3. Insert both output bearings (6) in the housing, using a round tube of the correct diameter and a hand press.
4. Slide output shaft (4) through both bearings (6) until it rests against top bearing (6).
5. Slide shim (16) over output shaft (4).
6. Press gear (5) onto output shaft (4) and secure with shim (17), castle nut (14), and cotter pin (9).
7. Apply grease to lower seal lips (18) and press seal (18) over output shaft (4), using a tube of the correct diameter. Be sure not to damage the seal lip.
8. Press in housing so that seal is recessed. Press protective seal (8) until seated flush with housing. Verify that the seal (8) is seated correctly.

9. Press bearing (7) into the housing, using a round tube of the correct diameter and a hand press. Secure with shim (13) and snap ring (10).
10. Secure snap ring (11) on input shaft (3) if not already secure.
11. Place gear (1) through top of housing and align gear (1) and gear (5) so that gear teeth are a match.
12. While holding gear (1) in place, slide input shaft (3) through gear (1) and bearing (7). Align splines on shaft (3) and gear (1).
13. Slide shim (12) over input shaft (3) and press bearing (7) onto input shaft (3), using a round tube of the correct diameter and a hand press.
14. Slide shim (13) over input shaft (3) and secure with snap ring (10).
15. Check input shaft end float by moving the input shaft (3) by hand. If end float is higher than 0.012", insert shim between input shaft (3) and rear bearing (7). Repeat until end float is less than 0.012". Check rotational torque by hand. The torque should be less than 2.2 lbs-inch.
16. Check that the gear backlash is between 0.006" and 0.016". You should not have to adjust the backlash.
17. Press in input oil seal (19), using tube of correct diameter. Be careful not to damage seal lip.
18. Press oil cap (20) on to cover the rear of housing, using a tube of the correct diameter.
19. Place top cover (22) on top of housing and secure with six cap screw (23).
20. Check gearbox housing for leaks by plugging all holes except one. Apply 4 psi compressed air and immerse the gearbox in water to verify that there are no leaks.
21. Remove gearbox from water and dry off with compressed air. Add SAE 80W or 90W EP oil to proper level. Tighten all plugs.

Reinstallation

NOTE: Gearbox is heavy: do not attempt to move without mechanical assistance.

1. Set gearbox on cutter and fasten with bolts and nuts. Torque bolts to 300 lbs-ft.
2. Attach crossbar (Crossbar Installation, page 31).

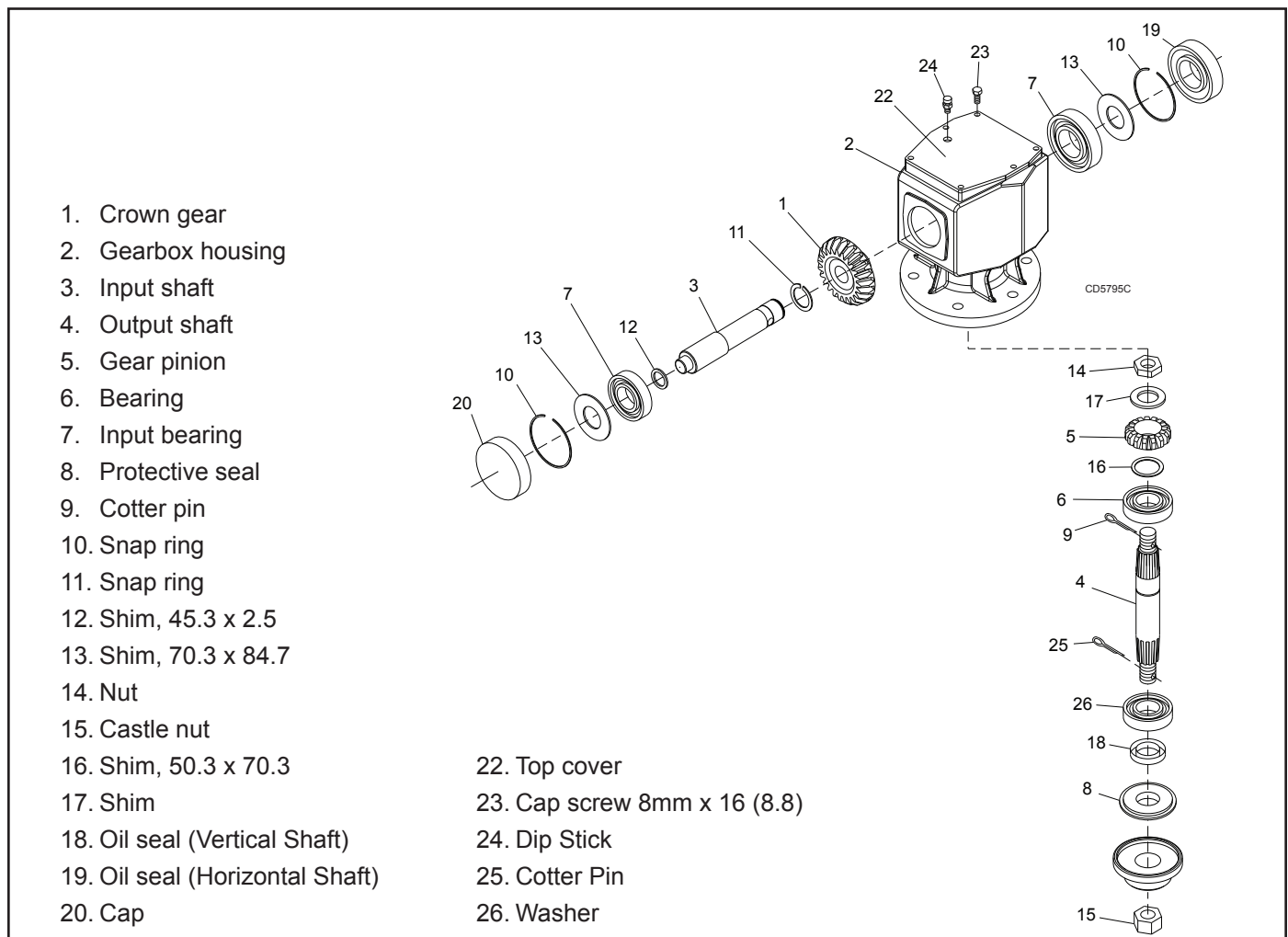

Figure 11. Gearbox

SPLITTER GEARBOX REPAIR

(Figure 12)

Removal from Cutter

1. Disconnect and remove all drivelines from gearbox.
2. Remove the four cap screw and lock washers that secure gearbox to cutter, and remove gearbox.

NOTE: Gearbox is heavy: do not attempt to move it without mechanical assistance.

Disassembly

Center Shaft

1. Remove plug from side of gearbox and pour out the gear oil.
2. Remove seal (11, to be replaced) from the front and rear of the center shaft (14).
3. Remove snap ring (10) and shim (12) from the front and rear of the center shaft (14).
4. Support gearbox in a hand press and push on the rear of the center shaft.
5. Remove bearing (13) from center shaft (14).
6. Remove six cap screws (20) and top cover (21) from the gearbox housing.
7. Remove gear (17) and bearing (16).
8. Snap ring (15) does not have to be removed from shaft (14) unless it is damaged.

Side Shaft

9. Remove seal (2, to be replaced) from the output shaft (1).
10. Remove snap ring (4) and shim (8) from output shaft (1).
11. Support gearbox in hand press. Using a punch through the front opening of the gearbox and, push shaft (1) and bearing (5) out the backside of housing.
12. Remove gear (6) from inside housing.
13. Remove bearing (7) and shim (8) by using a hammer and punch through front opening of the gearbox and force them out the backside of the housing.
14. Repeat steps 7 through 11 for opposite side shaft.

Inspect Components

15. Inspect gears for broken teeth and wear. Some wear is normal and will show on the loaded side of the teeth. Forged gear surfaces are rough when new. Check that wear pattern is smooth.
16. Inspect shafts for grooves, nicks, or bumps in the areas where seals seat. Resurface any damage with emery cloth or replace shaft. from gearbox.
17. Inspect housing and caps for cracks or other damage.

Assembly

1. Clean housing, pay specific attention to areas where gaskets are installed.
2. Wash housing and all components thoroughly.
3. Select a clean work area to assemble gearbox.
4. Replace all seals, bearings, and gaskets.
5. All parts must be clean and lightly oiled before assembly.

Side Shaft

6. Insert bearing (7) and shim (8) in housing using a round tube of the same size diameter and a hand press.
7. Place gear (6) inside the housing and slide output shaft (1) through gear (6) and into bearing (7).
8. Slide bearing (5) and shim (8) over output shaft. Secure with snap ring (4).
9. Check end play of shaft by moving it in and out. If end play is more than 0.012", insert another shim (8) between snap ring and bearing. Repeat process until end play is less than 0.012".
10. Check rotational torque. Torque should be less than 2.2 lbs-inch gear.
11. Place seal (2) over shaft and press into housing using a tube of the same diameter. Seal should be flush with housing when properly installed.
12. Repeat steps 6 through 10 for opposite side shaft.

Center Shaft

13. Place gear (17) inside housing and slide center shaft (14) through the gear from the front of the housing.
14. Slide bearings (16 & 13) and shims (12) over each end of the center shaft (14). Secure bearings into position using snap rings (10).
15. Check end play of shaft by moving it in and out. If end play is more than 0.012", insert another shim (12) between snap ring and bearing. Repeat process until end play is less than 0.012".
16. Check rotational torque. Torque should be less than 2.2 lbs-inch gear.
17. Check gear backlash, backlash should be between 0.006" and 0.016". You should not have to adjust for backlash.
18. Place seal (11) over shaft and press into housing using a tube of the same diameter. Seal should be flush with housing when properly installed. Repeat process for opposite end shaft.

Check Gearbox

1. Place top cover (21) on housing and secure into position using six cap screws (20).
 2. Check gearbox for leaks by: plugging all holes except one, applying 4 psi of compressed air, and immersing gearbox in water. Verify gearbox does not leak.
- NOTE:** Excessive air pressure will damage seals.
3. Remove gearbox from water and dry off.
 4. Remove upper plug (3) on right side of housing. Add SAE 80W or 90W EP oil until it runs out side level hole. Replace plug.

5. Install breather (18) in top cover.

Reinstallation on Cutter

NOTE: Gearbox is heavy: do not attempt to move it without mechanical assistance.

1. Place gearbox on cutter and secure into position using four cap screws and lock washers.
2. Torque hardware to 300 lbs-ft.
3. Attach all drivelines to gearbox.
4. Install all shields.

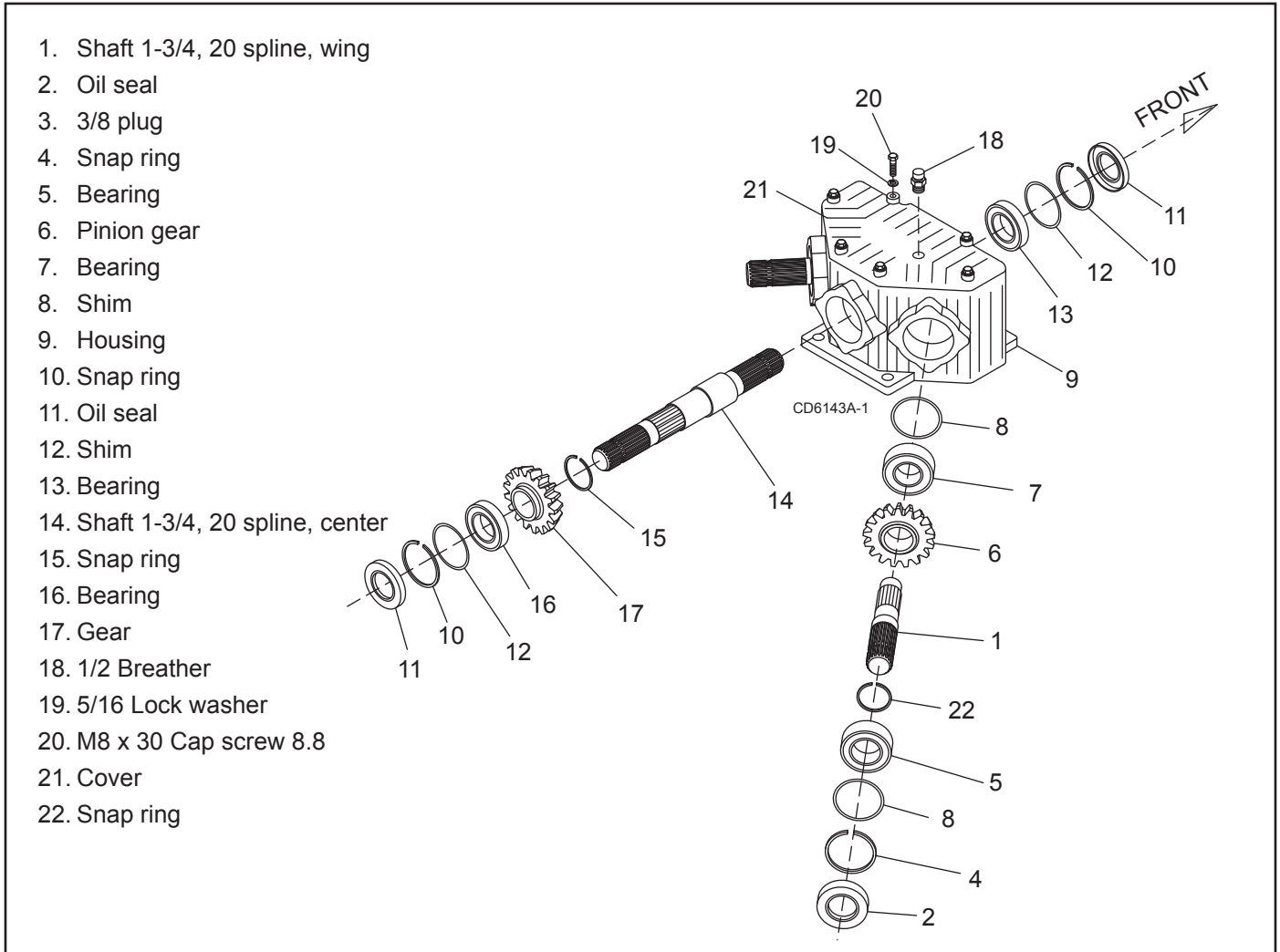

Figure 12. Splitter Gearbox Assembly

CROSSBAR REMOVAL

1. It is necessary to gain access to bottom side of cutter for crossbar removal. See Blocking Method page 19.

NOTE: You will need to use either the puller screw (Item 6, Figure 14) or a small hydraulic jack to remove the crossbar.

2. Remove blades from crossbar as shown in Figure 13.

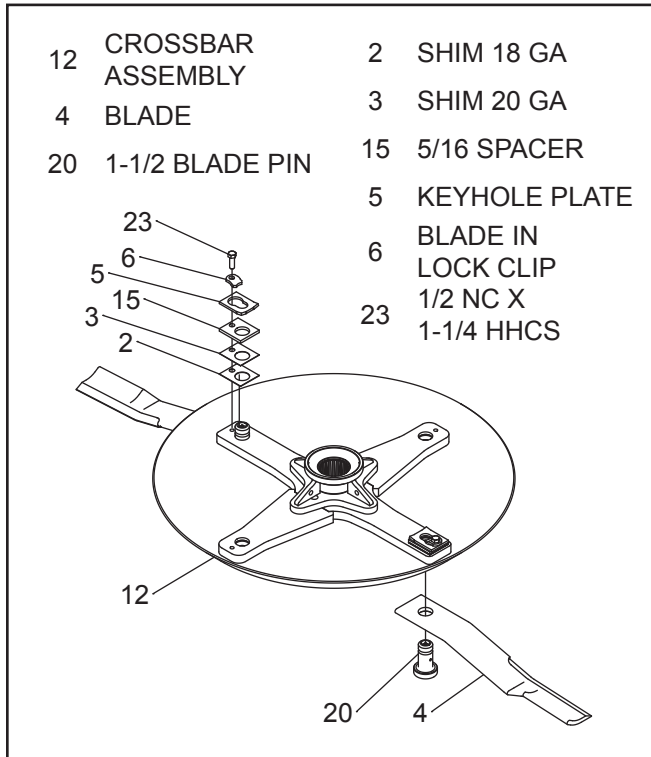

Figure 13. Blade Removal

3. Refer to Figure 14. Remove cotter pin from bottom of crossbar and remove nut and washer.
4. Attach a clevis (1) to each end of crossbar, using blade pins, spacers, keyhole plates, and blade pin clips.
5. Position tube assembly (5) with threaded nut (4) toward crossbar for puller screw removal or down for hydraulic jack removal.
6. For removal with puller screw, attach tube (5) to each clevis with bolts (2) and nuts (3). Place pad (4) in nut and thread puller screw (6) into nut from bottom. Tighten until pad is solid against gearbox shaft. For best results, strike head of puller screw with a hammer while tightening with a wrench.
7. For removal with a jack, attach tube to each clevis with puller links (7), bolts (2), and nuts (3). Place jack on tube with end of jack pressing against gearbox shaft. Slowly apply force with jack.

NOTE: Hydraulic jack will not operate if tipped more than 90°. Use care to prevent bending crossbar during removal.

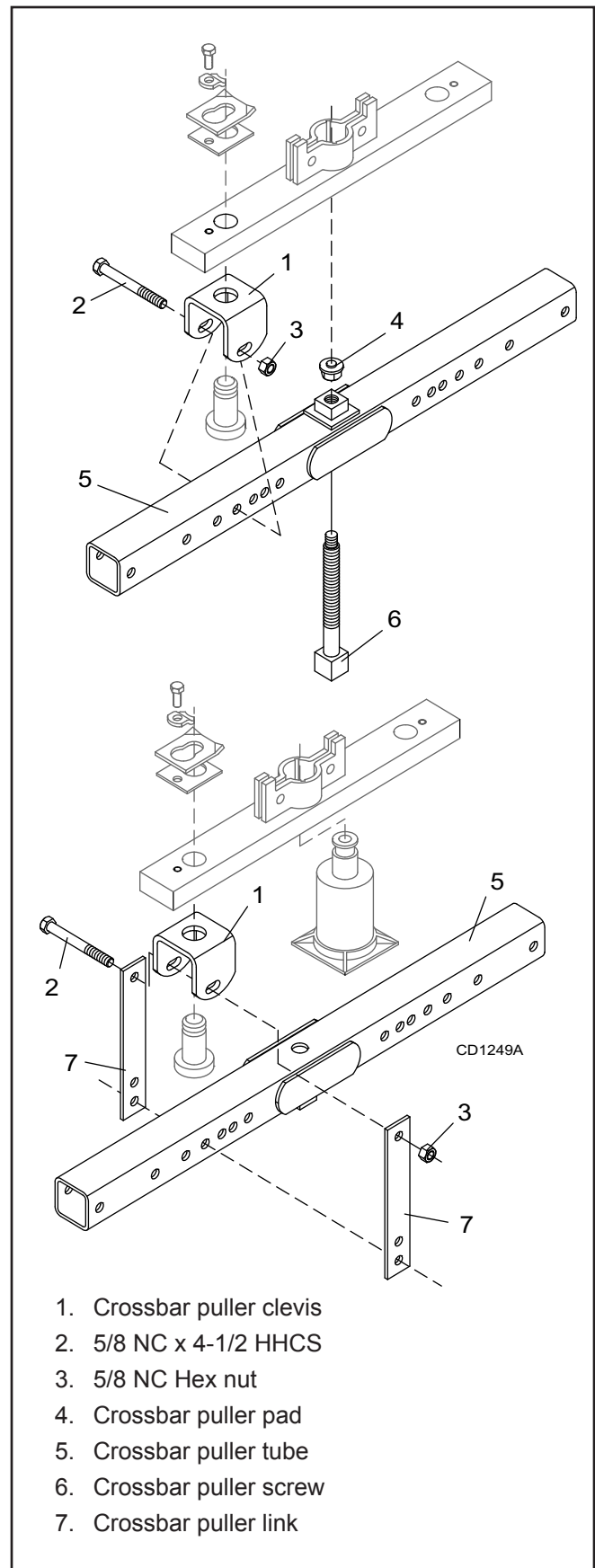

Figure 14. Crossbar Removal

CROSSBAR INSTALLATION

1. Using emery cloth (220 or finer), remove surface rust, Loctite® and foreign material from hub, splined gearbox vertical shaft, and crossbar assembly.
2. Slide crossbar assembly (10) onto splined shaft. Install washer (71) and nut (72) and align a slot with hole in splined shaft. Torque nut to 450 lbs-ft.
3. Install cotter pin (73) through slot in nut and bend ends over.

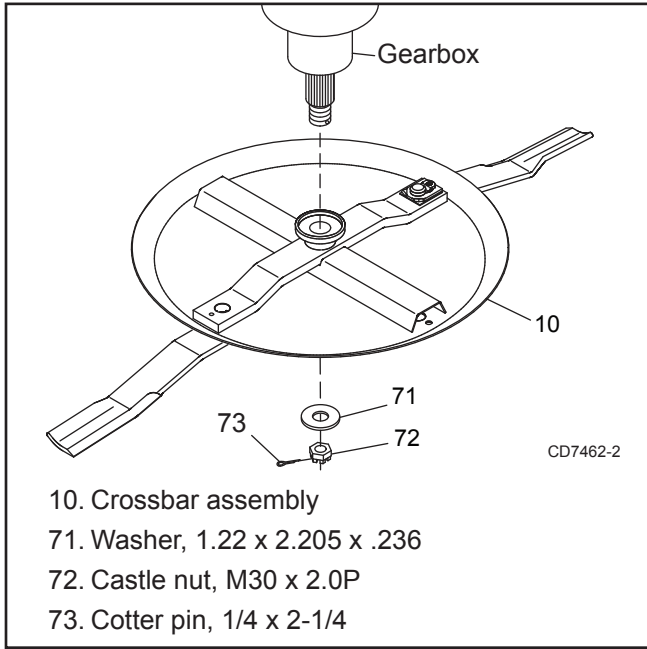

Figure 15. Crossbar Assembly Installation

UNIVERSAL JOINT REPAIR

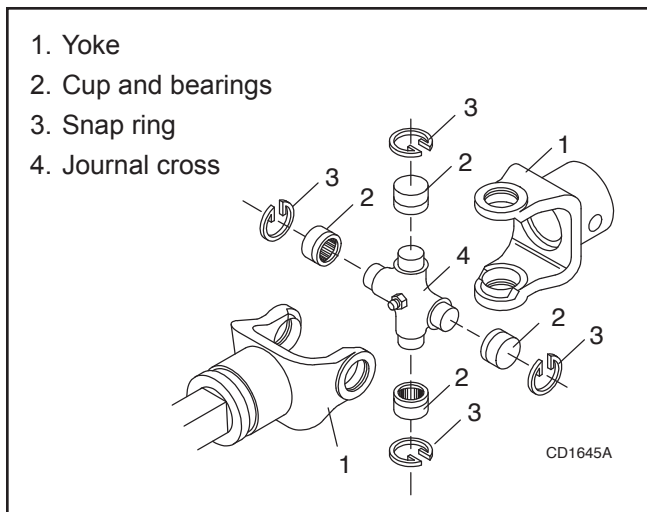

Figure 16. U-Joint Exploded View

U-Joint Disassembly

1. Remove external snap rings from yokes in four locations as shown in Figure 17.

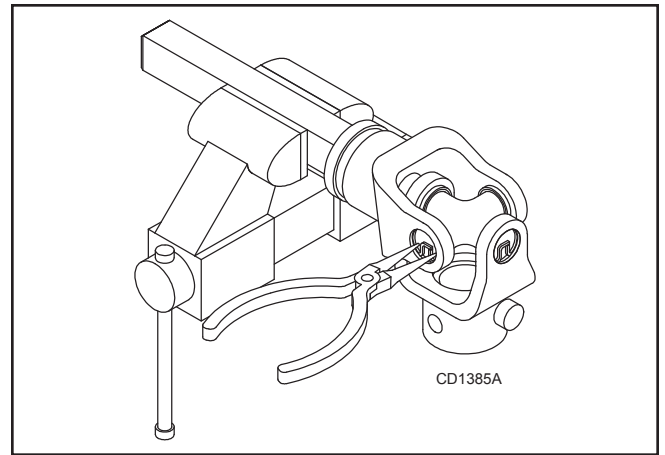

Figure 17.

2. With snap rings removed, support drive in vise, hold yoke in hand and tap on yoke to drive cup up out of yoke. See Figure 18.

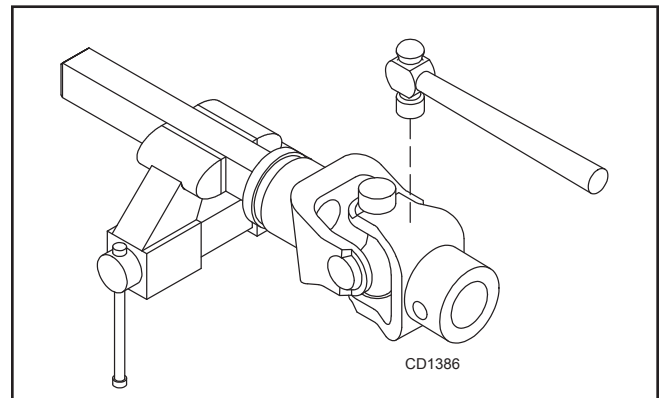

Figure 18.

3. Clamp cup in vise as shown in Figure 19 and tap on yoke to completely remove cup from yoke. Repeat Step 2 & Step 3 for opposite cup.

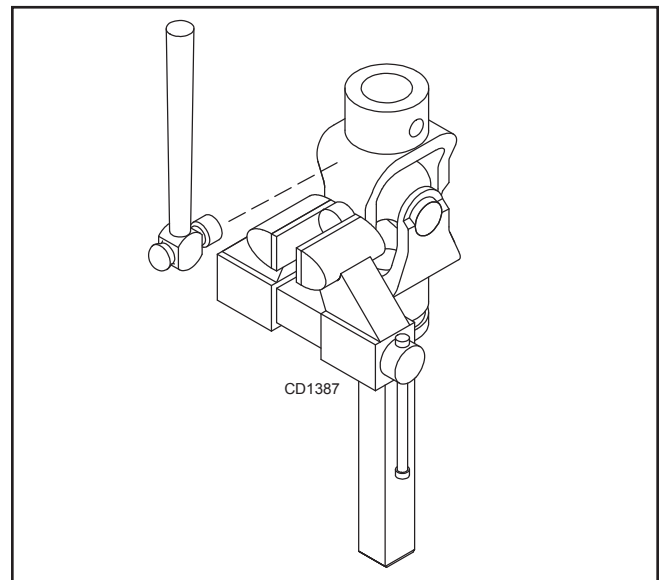

Figure 19.

- Place universal cross in vise as shown in Figure 20 and tap on yoke to remove cup. Repeat Step 3 for final removal. Drive remaining cup out with a drift and hammer.

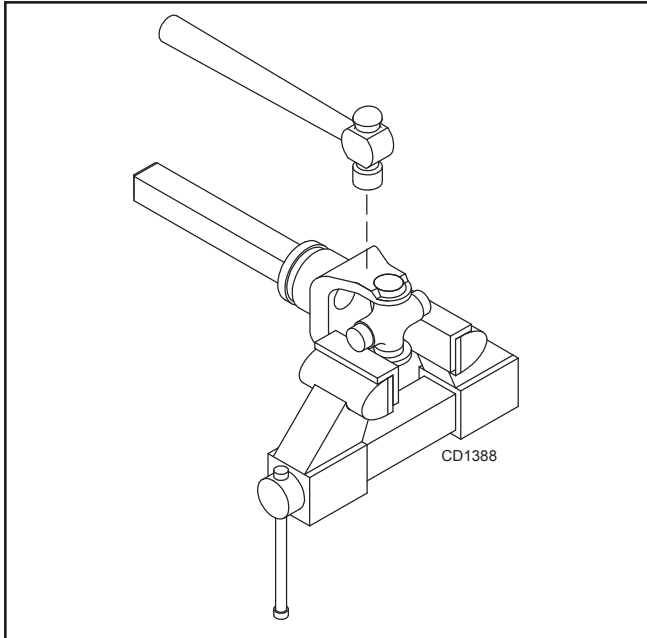

Figure 20.

U-Joint Assembly

- Place seals securely on bearing cups. Insert cup into yoke from outside and press in with hand pressure as far as possible. Insert journal cross into bearing cup with grease fitting away from shaft. Be careful not to disturb needle bearings. Insert another bearing cup directly across from first cup and press in as far as possible with hand pressure.
- Trap cups in vise and apply pressure. Be sure journal cross is started into bearings and continue pressure with vise, squeezing in as far as possible. Tapping the yoke will help.
- Seat cups by placing a drift or socket (slightly smaller than the cup) on cup and rap with a hammer. See Figure 31. Install snap ring and repeat on opposite cup.
- Repeat Step 1 and Step 2 to install remaining cups in remaining yoke.
- Move both yokes in all directions to check for free movement. If movement is restricted, rap on yokes sharply with a hammer to relieve any tension. Repeat until both yokes move in all directions without restriction.

SERVICING TIRES SAFELY

Used Aircraft Tires (Figure 21)

! WARNING



- Explosive separation of tire and rim parts can cause serious injury or death. Release all air pressure before loosening bolts.

Do not attempt to mount a tire unless you have the proper equipment and experience to perform the job.

Always maintain the correct tire pressure. Do not inflate tires above the recommended pressure. Never weld or heat a wheel and tire assembly. The heat can cause an increase in air pressure and result in a tire explosion. Welding can structurally weaken or deform the wheel.

When inflating tires, use a clip-on chuck and an extension hose long enough to allow you to stand to the side — not in front of or over the tire assembly. Use a safety cage if available.

Check wheels for low pressure, cuts, bubbles, damaged rims, or missing lug bolts and nuts.

Never remove split rim assembly hardware (A) with the tire inflated.

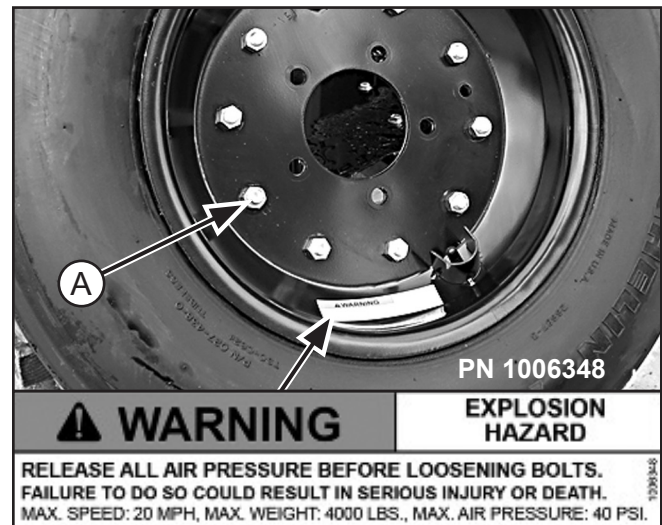

Figure 21. Split Rim Tire Servicing

ASSEMBLY INSTRUCTIONS

DEALER SET-UP INSTRUCTIONS

Assembly of this cutter is the responsibility of the WOODS dealer. It should be delivered to the owner completely assembled, lubricated and adjusted for normal cutting conditions.

The cutter is shipped partially assembled. Assembly will be easier if components are aligned and loosely assembled before tightening hardware. Recommended torque values for hardware are located on page 60.

Select a suitable working area. A smooth hard surface, such as concrete, will make assembly much quicker. Open parts boxes and lay out parts and hardware to make location easy. Refer to illustrations, accompanying text, parts lists and exploded view drawings.

Complete the checklist on page 35 when assembly is complete and cutter is delivered to the customer.

! WARNING

- Before working underneath, carefully read Operator's Manual instructions, disconnect driveline, raise mower, securely block up all corners with jackstands, and check stability. Secure blocking prevents equipment from dropping due to hydraulic leak down, hydraulic system failures, or mechanical component failures.
- Do not disconnect hydraulic lines until machine is securely blocked or placed in lowest position and system pressure is released by operating valve levers.

! CAUTION

- Always wear relatively tight and belted clothing to avoid getting caught in moving parts. Wear sturdy, rough-soled work shoes and protective equipment for eyes, hair, hands, hearing, and head; and respirator or filter mask where appropriate.

Small Aircraft Tires	Attitude Rod Length Beyond Nuts (34)
Tongue at 11"	3.5
Tongue at 18"	1.75
Large Aircraft Tires	
Tongue at 11"	4.5
Tongue at 18"	2.5

Install Wheel

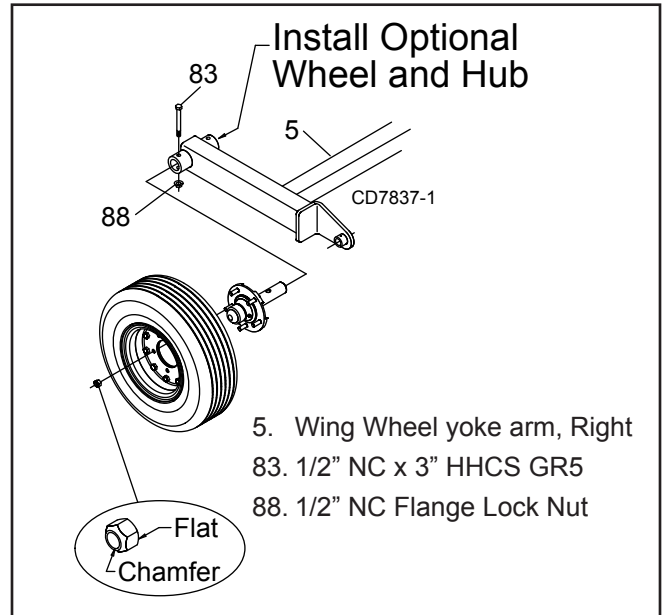

Figure 22. Center Section Wheel and Hub Installation

Install Wing Wheel

(Figure 23)

1. Insert wheel hub into wing wheel yoke arms (5) and align holes.
2. Secure into position using cap screw (83) and flanged lock nut (88).
3. Attach wheel to hub using five lug nuts. Install the chamfered side of the lug nut toward the inside for steel rim for pneumatic tires and rims. Tighten to 85 lbs-ft. Check that tire air pressure is a maximum of 40 psi.

NOTE: Install the flat side of the nut toward the inside for solid tires and aircraft tires (shown).

4. Install optional dual wheel and hub to inside of wheel yoke arm.

NOTE: Pneumatic (BW15.71 and BW15.71Q only), notat, and airplane tires are available for this cutter. See page 49 for parts list.

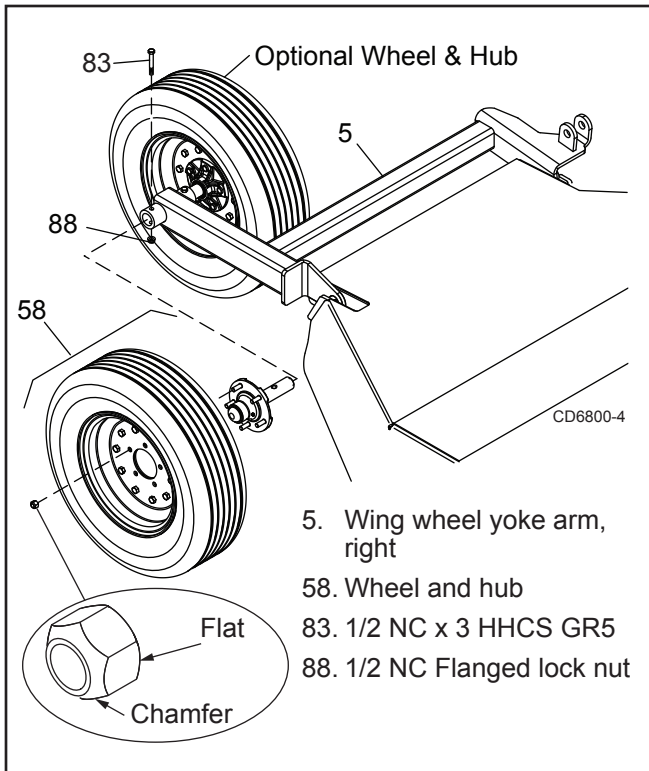

Figure 23. Wing Wheel - Right

Install Driveline

1. Remove driveline from wing.
2. Remove 5/8" retaining bolt from driveline.
3. Slide driveline yoke onto gearbox input shaft aligning retaining bolt hole to groove in shaft.
4. Reinstall 5/8" bolt and nut and torque to 110 ft-lbs.
5. Remove driveline shipping brackets from wing.
6. Replace bolts and nuts in skid shoe with carriage bolts and nuts found in manual tube.

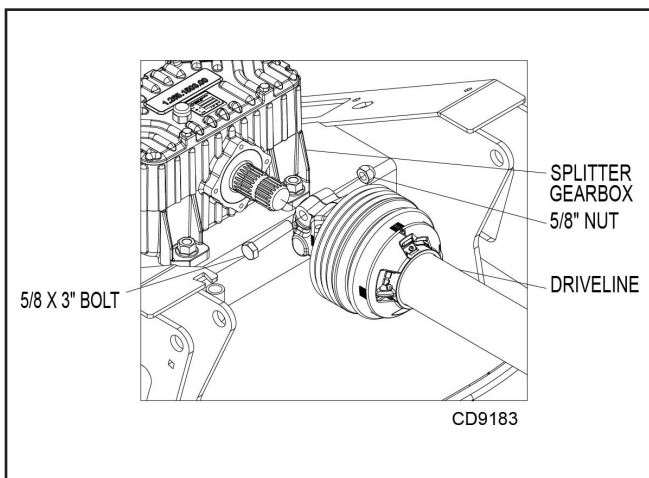

Figure 24. Driveline Installation

Winch Kit Installation (Optional)

Refer to page 57 for Installation and Operation instructions.

Tandem Axle Arm Installation (Optional)

Refer to page 58 for Installation and Operation instructions.

Shredding Kit Installation (Optional)

Refer to page 59 for Installation and Operation instructions.

Double Chain Installation (Optional)

NOTICE

DO NOT REMOVE SINGLE ROW CHAIN AS INSTALLED FROM FACTORY. DOUBLE ROW CHAIN KIT IS AN ADDITION TO STANDARD SINGLE ROW CHAIN SHOWN.

1. Raise unit to full height and install transport lock pin. See page 17. Refer to page 19 for blocking instructions.
2. Remove one single chain locking bracket from unit at a time.
3. Compare removed bracket with new double lock brackets to identify correct new part. Refer to Figure 25 for example.

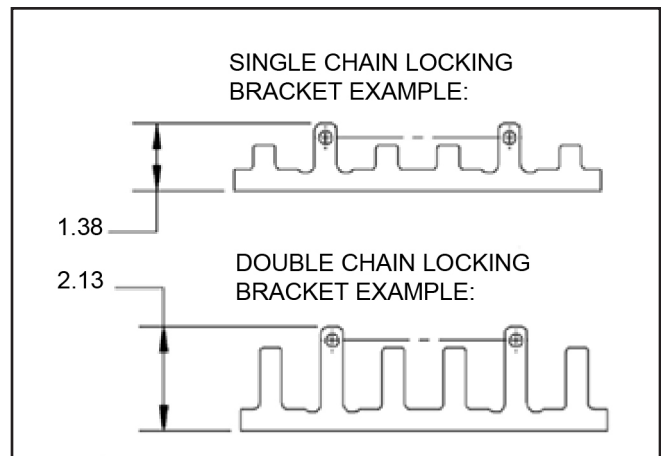

Figure 25.

4. Leave single chain in place except where noted.
5. Install chain as shown in pages 51 & 52, doubling over on center link and sliding over extended finger. Center chain loop may be vertical or horizontal as required for installation.
6. Install new lock bracket and attach with new hardware provided.
7. Repeat for each individual locking bracket.
8. Install rear chain flap on wing tail wheel arms if wing arm has lug for attachment. See page 51.

DEALER CHECKLISTS

DEALER PRE-DELIVERY CHECKLIST

(DEALER'S RESPONSIBILITY)

Inspect the equipment thoroughly after assembly to ensure it is set up properly before delivering it to the customer.

The following checklists are a reminder of points to inspect. Check off each item as it is found satisfactory or after proper adjustment is made.

- _____ Check that all safety decals are installed and in good condition. Replace if damaged.
- _____ Check that shields and guards are properly installed and in good condition. Replace if damaged.
- _____ Check all bolts to be sure they are properly torqued.
- _____ Check wheel bolts for proper torque.
- _____ Check that all cotter pins and safety pins are properly installed. Replace if damaged.
- _____ Check that blades have been properly installed.
- _____ Check and grease all lubrication points as identified in lubrication information on page 20.
- _____ Check the level of gearbox fluids before delivery. Service, if required, as specified in the lubrication information on page 20.

DELIVERY CHECKLIST

(DEALER'S RESPONSIBILITY)

- _____ Show customer how to make adjustments and select proper PTO speed.
- _____ Show customer how to make sure driveline is properly installed and that spring-activated locking pin or collar slides freely and is seated in groove on tractor PTO shaft.
- _____ Show customer how to determine the turning limits of the CV PTO driveline.

- _____ Show customer the safe, proper procedures to be used when mounting, dismounting, and storing equipment.
- _____ Make customer aware of optional equipment available so that customer can make proper choices as required.
- _____ Instruct customer how to lubricate and explain importance of lubrication.
- _____ Point out the safety decals. Explain their meaning and the need to keep them in place and in good condition. Emphasize the increased safety hazards when instructions are not followed.
- _____ Explain to customer that when transporting the cutter, the wing and center sections should be raised and their respective transport bars installed and pinned in place.
- _____ Present Operator's Manual and request that customer and all operators read it before operating equipment. Point out the manual safety rules, explain their meanings and emphasize the increased safety hazards that exist when safety rules are not followed.
- _____ Explain to customer the potential crushing hazards of going underneath raised equipment. Instruct that before going underneath to disconnect the driveline, securely block up all corners with jack stands and to follow all instructions in the BLOCKING METHOD, page 19 of the operator's manual. Explain that blocking up prevents equipment dropping from hydraulic leak down, hydraulic system failures or mechanical component failures.
- _____ Point out all guards and shields. Explain their importance and the safety hazards that exist when not kept in place and in good condition.
- _____ Explain to customer that when towing on a public road to comply with all state and local lighting/marketing laws and to use a safety tow chain.



BATWING® Rotary Cutter

BW15.71, BW15.71Q

BW10.71, BW10.71Q

CENTER FRAME ASSEMBLY	37
CYLINDER ASSEMBLY	38
WING ASSEMBLY	39
WHEEL ARM ASSEMBLY, SINGLE ARM	40
WHEEL ARM ASSEMBLY, SPRING ARM	41
TONGUE ASSEMBLY	42 - 43
WING & CENTER GEARBOX ASSEMBLY	44
SPLITTER GEARBOX ASSEMBLY	45
DRIVE ASSEMBLY	
CENTER DECK	46
WING	47
540 RPM & 1000 RPM FRONT	48
5-BOLT WHEEL & TIRE ASSEMBLY	49
LIGHT KIT ASSEMBLY.	50
CHAIN SHIELDING - REAR	51
CHAIN SHIELDING - FRONT	52
HYDRAULIC CYLINDERS.	53 - 54
HYDRAULIC CYLINDER STROKE CONTROL KIT	55
CROSSBAR PULLER (OPTIONAL)	55
BW10.71 / BW10.71Q COUNTERWEIGHT BOX ASSEMBLY (OPTIONAL)	56
WINCH KIT (OPTIONAL)	57
TANDEM AXLE (OPTIONAL)	58
SHRED KIT (OPTIONAL)	59

CENTER FRAME ASSEMBLY

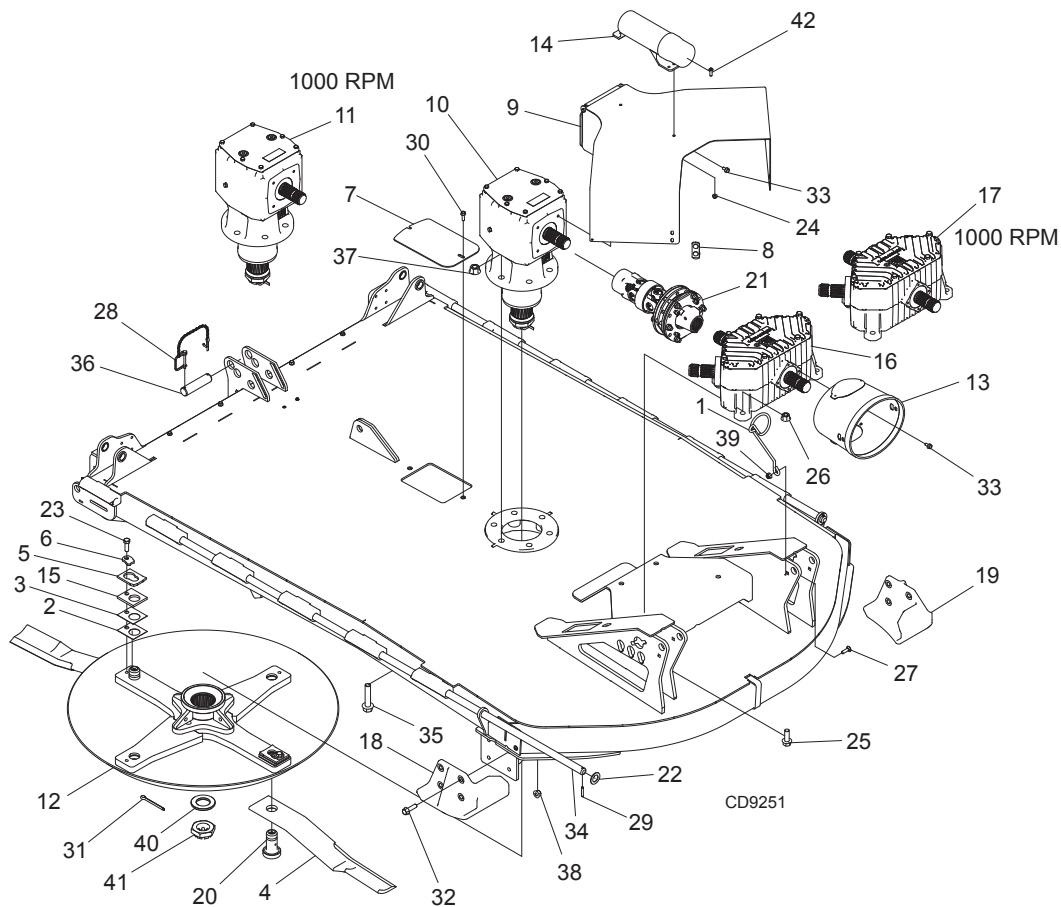

REF	PART	QTY	DESCRIPTION	REF	PART	QTY	DESCRIPTION
1	3443	1	HYD HOSE HOLDER	23	3379	2	BOLT, HEX 1/2 NC X 1.50 GR5
2	10520RP	2	BLADE SHIM .0478	24	14139	2	NUT, HEX FLNG LOCK 5/16 NC
3	13946RP	2	BLADE SHIM .0359	25	19024	4	BOLT, HEX FLNG 5/8 NC X 1.75 GR5
4	19160KT	1	KIT, BLADE, 19160 STD	26	19025	4	NUT, HFN 5/8 NC, LOCK
5	32603	2	KEYHOLE PLATE SPECIAL	27	20973	1	BOLT CRG 3/8 NC X 1-1/4 GR5
6	32604RP	2	BLADE PIN LOCK CLIP	28	52204	1	ASY-LYNCH PIN, CHAIN & COTTER
7	610630RP	1	LINK, ACCESS COVER	29	66016	4	1/4 X 1-1/2 SPIROL PIN
8	611379RP	2	ASY, CTR SHIELD MAGNET	30	71632	2	BOLT, HEX FLNG 5/16 NC X 1.00, SRTD
9	611420RP	1	CENTER SHIELD	31	603838	1	PIN, COTTER, 8MM X 90 MM
10	617178RP	1	GEARBOX W/DIPSTICK, NUT 540 RPM	32	1028902	8	BOLT, HEX FLNG 1/2 NC X 1.75 GR8
11	617179RP	1	GEARBOX W/DIPSTICK, NUT 1000 RPM	33	1041071	8	BOLT, HEX FLNG M8 X16 CL8.8, DRI-LOC
12	631415RP	1	CROSSBAR	34	1043438	2	PIN, HINGE
13	1002048	1	CLUTCH SHIELD, 3.96&5.64 BC	35	1043460	6	BOLT, HEX FLNG 3/4 NC X 3.50 GR5
14	1003828	1	MANUAL TUBE	36	1044831	1	PIN, 1.25 X 5.00
15	1028824RP	2	SPACER 5/16	37	1045611	6	NUT, HFN 3/4 NC, LOCK
16	1031185	1	GEARBOX COMPLETE 1:1.35/1:1	38	1045624	8	NUT, HFN 1/2 NC, LOCK
17	1031186	1	GEARBOX COMPLETE 1.35:1/1:1	39	1045628	1	NUT, HFN 3/8 NC, LOCK
18	1044390	1	SKID, SHOE RT	40	1045695	1	WASHER, BLANK
19	1044391	1	SKID SHOE, LT	41	1045894	1	NUT, CASTLE M48 X 3
20	1045034RP	2	BLADE PIN W/GREASE FITTING	42	1046050	2	SCREW, BTN HD 5/16NC X 1.0
21	1045078	1	DRV, 2JT FXD-2400A 1.75-20,3.4CL				
22	1863	2	WASHER, FLAT, 1 SAE ZP				

CYLINDER ASSEMBLY

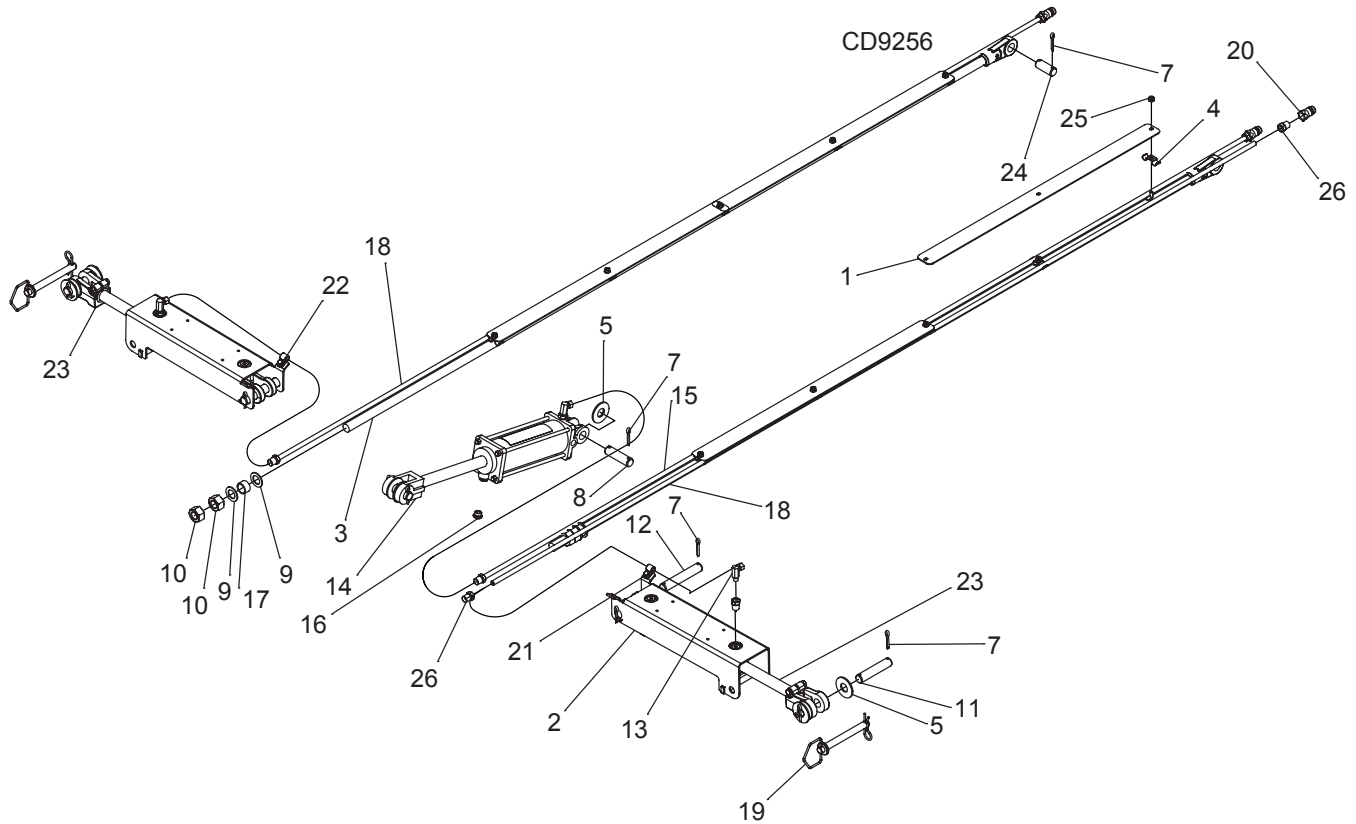

REF	PART	QTY	DESCRIPTION	REF	PART	QTY	DESCRIPTION
1	618172RP	4	LINK, HOSE COVER	16	11975	1	1/2 NPT VENT PLUG
2	631411RP	2	WA, WING LOCK	17	33647	2	PIPE 1 SCH 40 X 0.75
3	1045612RP	2	WA, ATTITUDE ROD, 1.0	18	52201	2	HOSE .25 ID X .25 NPT X 264
4	258	10	FEEDLINE CLAMP - 1/2	19	55318	2	HITCH PIN .75 X 6.25
5	832	8	WSHR 1 STD FLAT	20	66511	3	CPLR MALE ISO 1/2 NPT
7	1285	16	1/4 X 1-1/2 COTTER PIN	21	71632	2	BOLT, HEX FLNG 5/16 NC X 1.00, SRTD
8	1631	2	PIN, HDLS 1.00 X 2.72	22	78059	2	CLAMP .50 DIA STEEL CUSHION
9	1863	4	WASHER, FLAT 1	23	597269	2	CYLINDER, 3.0 X 1.25 X 10.0 NPT8
10	3132	4	NUT HEX 1 NC ZP	24	1044832	2	PIN, 1.0 X 2.50
11	8345	2	PIN HDLS 1.00 X 4.08	25	1045655	10	NUT, HFN 5/16 NC, CTR LOCK
12	8347	2	PIN, HDLS 1.00 X 5.08	26	W11893	9	ADAPTER 1/4 NPTF 1/2 NPTM
13	10290	3	1/4 X 1/4 90 EL 1/16 RSTR				
14	10475	1	3-1/2X8 HYD CYLWBRETHR				
15	11817	1	HOSE .25ID X .25NPT X230				

WING ASSEMBLY

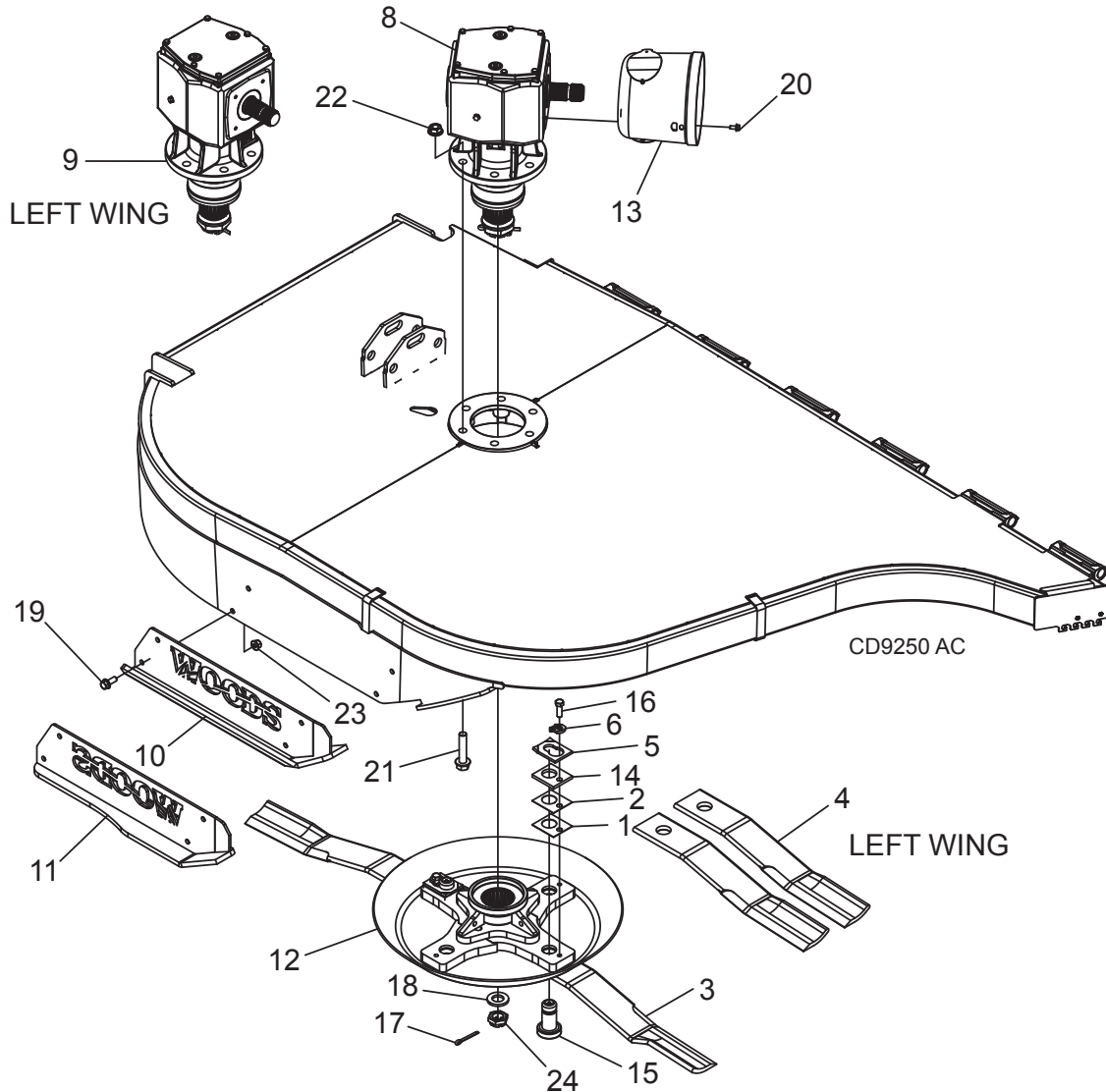

REF	PART	QTY	DESCRIPTION	REF	PART	QTY	DESCRIPTION
1	10520RP	2	BLADE SHIM .0478	15	1045034RP	2	BLADE PIN W/GREASE FITTING
2	13946RP	2	BLADE SHIM .0359	16	3379	2	BOLT, HEX 1/2 NC X 1.50 GR5
3	19160KT	1	CCW BLADE KIT	17	603838	•	PIN, COTTER, 8MM X 90 MM
4	19161KT	1	CW BLADE KIT	18	1045695	1	WASHER, 49MM X 85MM X 7MM
5	32603	2	KEYHOLE PLATE	19	1031225	1	BOLT, HEX FLNG 1/2 NC X 1.25 GR5
6	32604RP	2	BLADE PIN LOCK CLIP	20	1041071	1	BOLT, HEX FLNG M8 X16 CL8.8, DRI-LOC
8	617180RP	1	GEARBOX, REPAIR CW 1:1.37 W/BAG	21	1043460	1	BOLT, HEX FLNG 3/4 NC X 3.50 GR5
9	617181RP	1	GEARBOX, REPAIR CCW 1:1.37 W/BAG	22	1045611	1	NUT, HFN 3/4 NC, CTR LOCK
10	1044990RP	1	SKID, RIGHT	23	1045624	1	NUT, HFN 1/2 NC, CTR LOCK
11	1044991RP	1	SKID, LEFT	24	1045894	1	CASTLE NUT, M48 X 3.0
12	631806RP	1	CROSSBAR				
13	1002048	1	CLUTCH SHIELD, 3.96&5.64 BC				
14	1028824RP	2	SPACER 5/16				
							* OBTAIN LOCALLY

WHEEL ARM ASSEMBLY, SINGLE SPRING

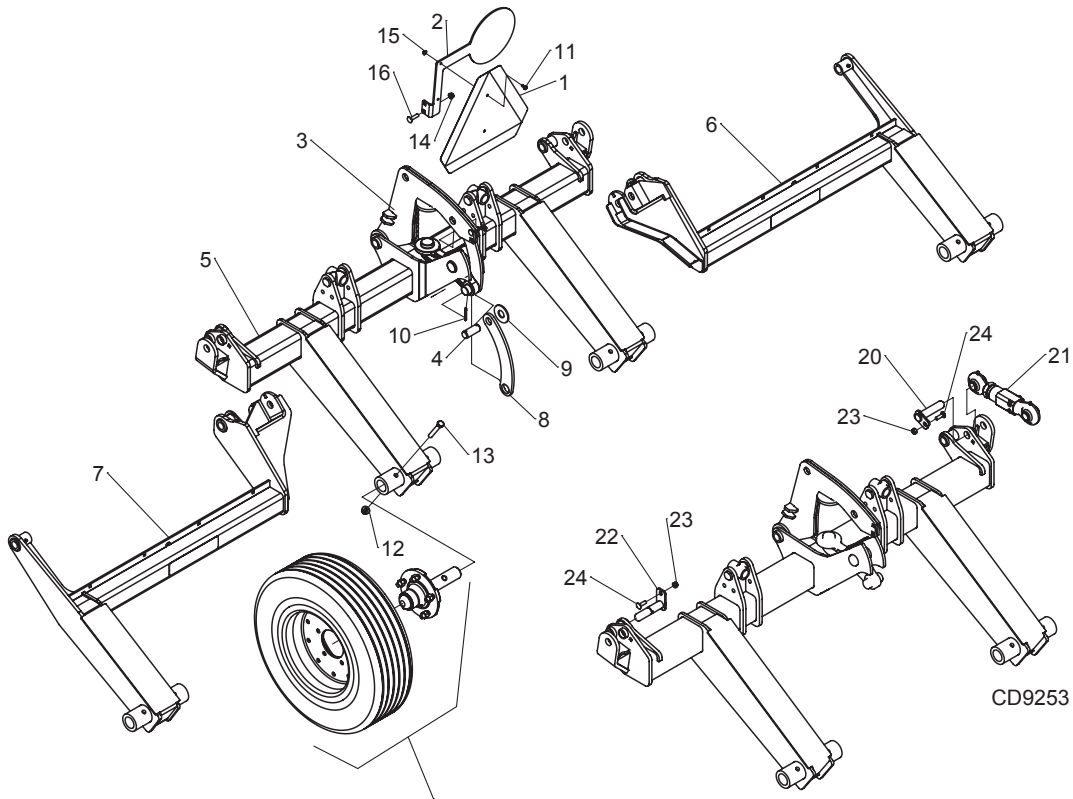

SEE PAGE 49 FOR TIRE AND HUB.

REF	PART	QTY	DESCRIPTION
1	24611	1	SIGN (SMV) SLOW MOVING VEHICLE
2	618171RP	1	LINK, SMV BRACKET
3	1032100	1	SPRING, COMPRESSION 3.25X.56X7.25X1113
4	1044832	1	PIN, 1.0 X 2.50
5	1044886RP	1	ASY, WHEEL ARM CTR, RIGID
6	1045008RP	1	ASY, WHEEL ARM RIGID, RT
7	1045009RP	1	ASY, WHEEL ARM RIGID, LT
8	1045012RP	2	LINK, DOGBONE
9	832	2	WSHR 1 STD FLAT
10	1266	2	3/16 X 1-1/2 COTTER PIN
11	*	2	HHCS 1/4 NC X 1/2 GR5
12	11900	1	NUT LOCK 1/2 NC FLANGE
13	14069	1	HHCS 1/2 NC X 3-1/4
14	14350	2	NUT, HEX FLNG LOCK 3/8 NC
15	W70065	2	NUT, HEX FLNG 1/4 NC SRTD
16	W301104	2	BOLT CRG 3/8 NC X 1-1/2 ZP

* OBTAIN LOCALLY

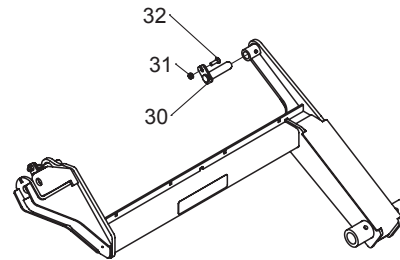

ITEMS INCLUDED WITH #5

REF	PART	QTY	DESCRIPTION
20	1038100	4	WA, PIN 1.0 X 3.81
21	1039950	2	ADJUSTABLE LINK, TRUNNION
22	1044844	3	WA, PIN 1.0 X 4.15
23	14350	7	NUT, HEX FLNG LOCK 3/8 NC
24	20973	7	BOLT CRG 3/8 NC X 1-1/4 GR5

ITEMS INCLUDED WITH #6 & 7

REF	PART	QTY	DESCRIPTION
30	1038100	2	WA, PIN 1.0 X 3.81
31	14350	2	NUT, HEX FLNG LOCK 3/8 NC
32	20973	2	BOLT CRG 3/8 NC X 1-1/4 GR5

WHEEL ARM ASSEMBLY, SPRING ARM

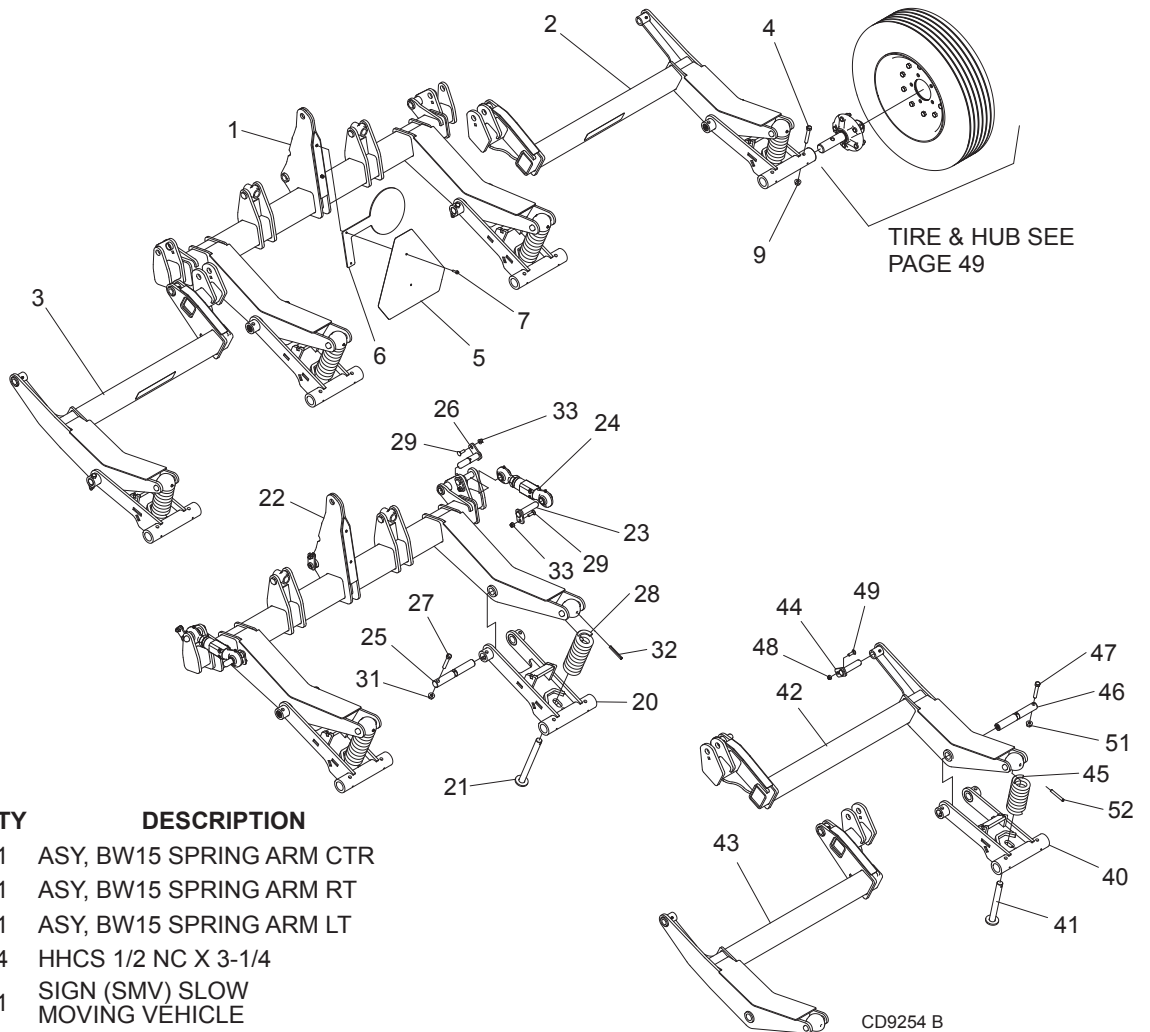

REF	PART	QTY	DESCRIPTION
1	603632RP	1	ASY, BW15 SPRING ARM CTR
2	603633RP	1	ASY, BW15 SPRING ARM RT
3	603634RP	1	ASY, BW15 SPRING ARM LT
4	14069	4	HHCS 1/2 NC X 3-1/4
5	24611	1	SIGN (SMV) SLOW MOVING VEHICLE
6	618170RP	1	LINK, SMV
7	1041087	2	SCREW, HFS-6 LOBE, 1/4 NCX1.0 GR5, PATCH
8	1045000	2	NUT, 1/4-20 UNC BLIND HOLE, HEX (NS)
9	1045624	4	NUT, HFN 1/2 NC, LOCK

ITEMS INCLUDED WITH #2 & 3

REF	PART	QTY	DESCRIPTION
40	610551RP	1	WA, SPRING ARM, WING
41	610635RP	1	WA, PIN 1.00X 8.38
42	620998RP	1	WA, WHEEL ARM, RT
43	620999RP	1	WA, WHEEL ARM, LT
44	630706	2	WA, PIN 1.0 X 3.81
45	1032100	1	SPRING, COMPRESSION 3.25X.56X7.25X1113
46	1044895	1	PIN, 1.25 X 9.13
47	3489	1	HHCS 1/2 NC X 3 GR5 ZP
48	14350	2	NUT, HEX FLNG LOCK 3/8 NC
49	20973	2	BOLT CRG 3/8 NC X 1-1/4 GR5
50	1043432	1	ZERK, 1/4 DRIVE TYPE (NS)
51	1045624	1	NUT, HFN 1/2 NC, LOCK
52	1046049	1	PIN, SPIROL 3/8X3 HVY

ITEMS INCLUDED WITH #1

REF	PART	QTY	DESCRIPTION
20	610549RP	2	WA, SPRING ARM, CTR
21	610634RP	2	WA, PIN 1.00X 10.88
22	620997RP	1	WA, WHEEL ARM, CTR
23	630706	4	WA, PIN 1.0 X 3.81
24	1039950	2	ADJUSTABLE LINK, TRUNNION
25	1044895	2	PIN, 1.25 X 9.13
26	1044844	3	WA, PIN 1.0 X 4.15
27	3489	2	HHCS 1/2 NC X 3 GR5 ZP
28	19710RP	2	SPR/CMP3.25 .69 9.52200
29	20973	7	BOLT CRG 3/8 NC X 1-1/4 GR5
30	1043432	2	ZERK, 1/4 DRIVE TYPE (NS)
31	1045624	2	NUT, HFN 1/2 NC, LOCK
32	1046049	2	PIN, SPIROL 3/8X3 HVY
33	1045628	7	NUT, HFN 3/8 NC, LOCK

NS NOT SHOWN

TONGUE ASSEMBLY

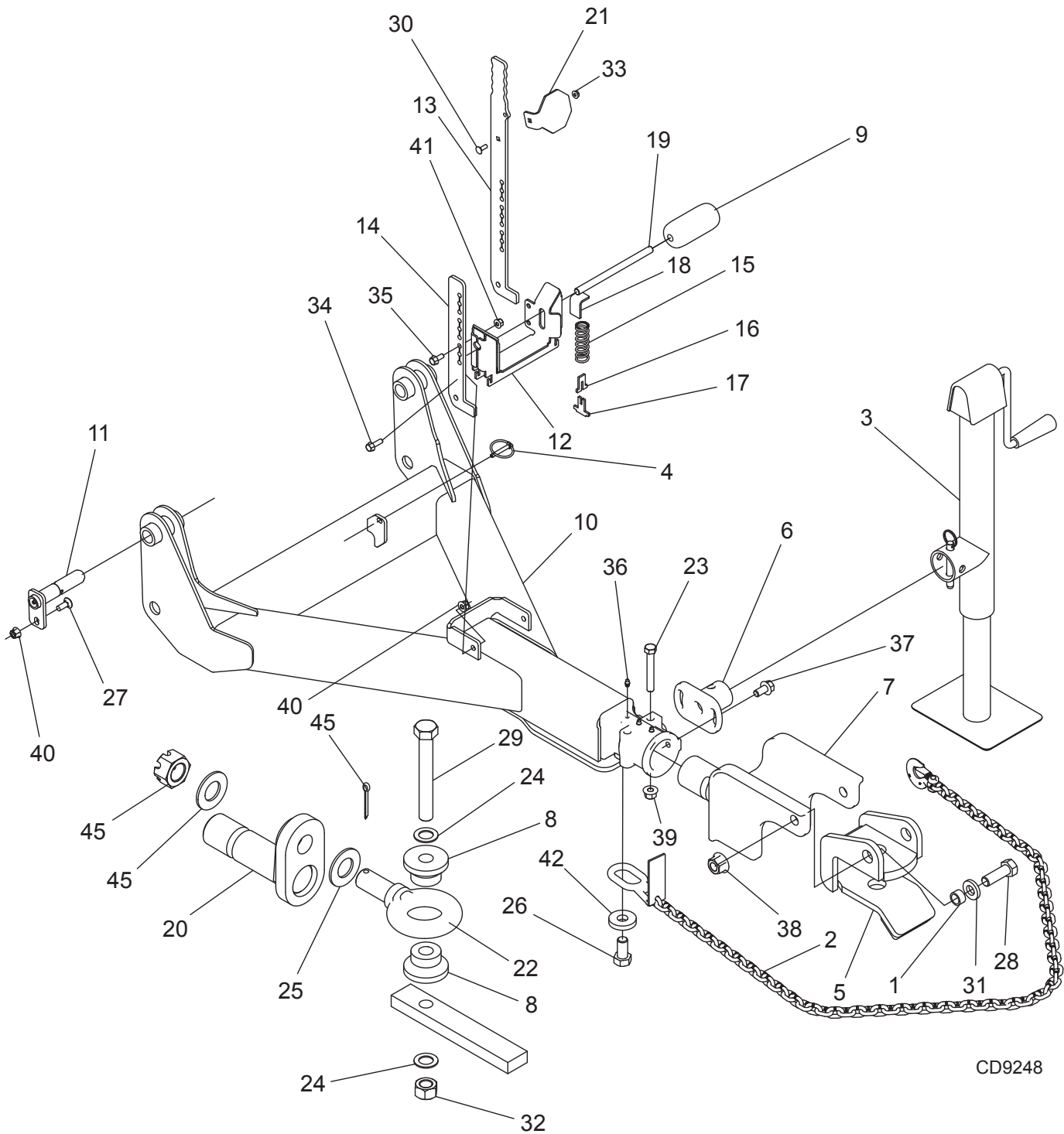

CD9248

TONGUE ASSEMBLY

REF	PART	QTY	DESCRIPTION
1	637530	2	SLV 3/4 X 1 X .656 HT
2	19407	1	ASY, SAFETY CHAIN, 10,000 LB
3	52232	1	SWIVEL PARKING JACK
4	62043	1	1/4 X 1-3/4 KLIK PIN
5	603944RP	1	WA, TONGUE CLEVIS, BW
6	614116RP	1	MOUNT, CAST JACK
7	614191RP	1	HITCH, CAST W/STOP
8	1016969	2	PINTLE BSHG 1.06X3.25X1.75
9	1029865	1	ROLLER 2 X 4.38
10	1043425RP	1	WA, TONGUE
11	1044844	1	WA, PIN 1.0 X 4.15
12	1044930RP	1	WA, SPRING LIFT
13	1045024RP	1	LINK, CV LIFT ARM
14	1045025RP	1	LINK, CV LIFT
15	1045026	1	SPRING, 1.0 X 3.0 - 65LB
16	1045027RP	1	LINK, SPRING
17	1045028RP	1	LINK, SPRING T
18	1045029RP	1	ANGLE, SPRING
19	1045030	1	PIN, .50 X 7.63
20	1045704RP	1	WA, HITCH
21	1045818RP	1	LUG, STOP
22	W11267	1	D315 ETC PINTLE RING
23	1637	2	BOLT, HEX 1/2 NC X 3.50 GR5
24	1863	2	WASHER, FLAT 1
25	2370	1	WSHR 1.62 X 3 X .18
26	4616	1	HHCS 3/4 NC X 1-1/2 GR5 ZP
27	6697	1	BOLT CRG 3/8 NC X 1 GR5 ZP
28	30068	2	HHCS 3/4 NC X 2-1/2 GR5 ZP
29	15278	1	HHCS 1 NC X 7.50 GR5
30	*	1	BOLT CRG 1/4 NC X 3/4
31	28873	2	WSHR 3/4ID 1-1/2OD 1/4THICK
32	34279	1	NUT, HEX LOCK 1 NC
33	62521	1	NUT LOCK 1/4 NC FLANGE
34	71632	1	BOLT, HEX FLNG 5/16 NC X 1.00, SRD
35	71851	2	BOLT, HEX FLNG 5/16 NC X .75 GR5
36	1043432	3	ZERK, 1/4 DRIVE TYPE
37	1045070	2	SCREW, HFS, 1/2 NC X 1.0 GR5
38	1045611	2	NUT, HFN 3/4 NC, CTR LOCK
39	1045624	2	NUT, HFN 1/2 NC, CTR LOCK
40	1045628	2	NUT, HFN 3/8 NC, CTR LOCK
41	1045655	2	NUT, HFN 5/16 NC, CTR LOCK
42	W8424	1	WSHR 3/4ID 2OD 3/8 THICK

* OBTAIN LOCALLY

WING & CENTER GEARBOX ASSEMBLY

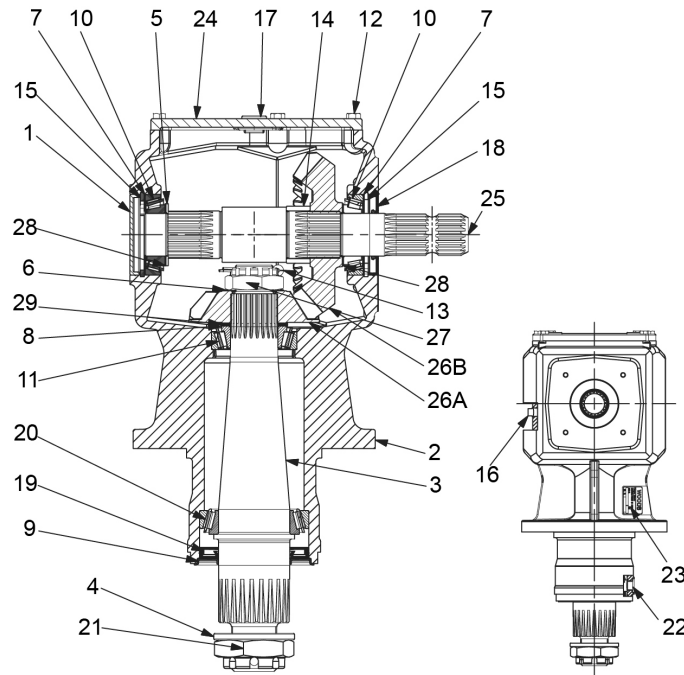

REF	QTY	DESCRIPTION	CENTER		RIGHT	LEFT
			540 RPM	1000 RPM		
		Complete box	617178RP	617179RP	617180RP	617181RP
1	1	Cap 85 x 10	57371	57371	57371	57371
2	1	Housing	-----	-----	-----	-----
3	1	Output shaft	1045672	1045672	1045672	1045672
4	1	Blank washer 49 x 85 x 7	1045695	1045695	1045695	1045695
5	1	Shim 45.3 x 65.3 x 2.5	57471	57471	57471	57471 KIT
6	1	Shim 40.3 x 61.7 x 1.0	57471	57471	57471	57471 KIT
7	2	Shim kit 70.3 x 84.7	57471	57471	57471	57471 KIT
8	2	Shim kit 50.30 x 70.3	57471	57471	57471	57471 KIT
9	1	Seal protector	1045700	1045700	1045700	1045700
10	2	Taper roller bearing 30209	39411	39411	39411	39411
11	1	Bearing 322210	-----	-----	-----	-----
12	6	Bolt HHG M8 x 25	-----	-----	-----	-----
13	1	Cotter pin B5 x 60	-----	-----	-----	-----
14	1	Spacer 50 x 60 x 25	-----	-----	-----	-----
15	2	Snap ring hole D85 DIN472	1045887	1045887	1045887	1045887
16	1	Plug external 3/8" GAS	27326	27326	27326	27326
17	2	Plug 1/2" GAS	-----	-----	-----	-----
18	1	Dust lip oil seal 45 x 85 x 10	57318	57318	57318	57318
19	1	Oil seal NAK TCA3 NBR 75 x 115 x 12	1045888	1045888	1045888	1045888
20	1	Roller bearing 32015X	1045889	1045889	1045889	1045889
21	1	Castle nut M48 x 3	1045894	1045894	1045894	1045894
22	1	Magnetic plug 3/8	-----	-----	-----	-----
23	1	Name plate	-----	-----	-----	-----
24	1	Cover	1045895	1045895	1045895	1045895
25	1	Shaft	-----	-----	-----	-----
26	1	Bevel gear set	1043503	-----	-----	-----
27	1	Castle nut M40 x 1.5	-----	-----	-----	-----
28	2	Shim 45.3 x 65.3 x 1.0	1045898	1045898	1045898	1045898
29	2	Shim 50.30 x 70.3 x 1.0	57471	57471	57471	57471 KIT
30	1	Dipstick breather plug (NS)	1045872	1045872	1045872	1045872
31	1	Cotter pin B8 X 90 (NS)	-----	-----	-----	-----

NS Not shown

SPLITTER GEARBOX ASSEMBLY

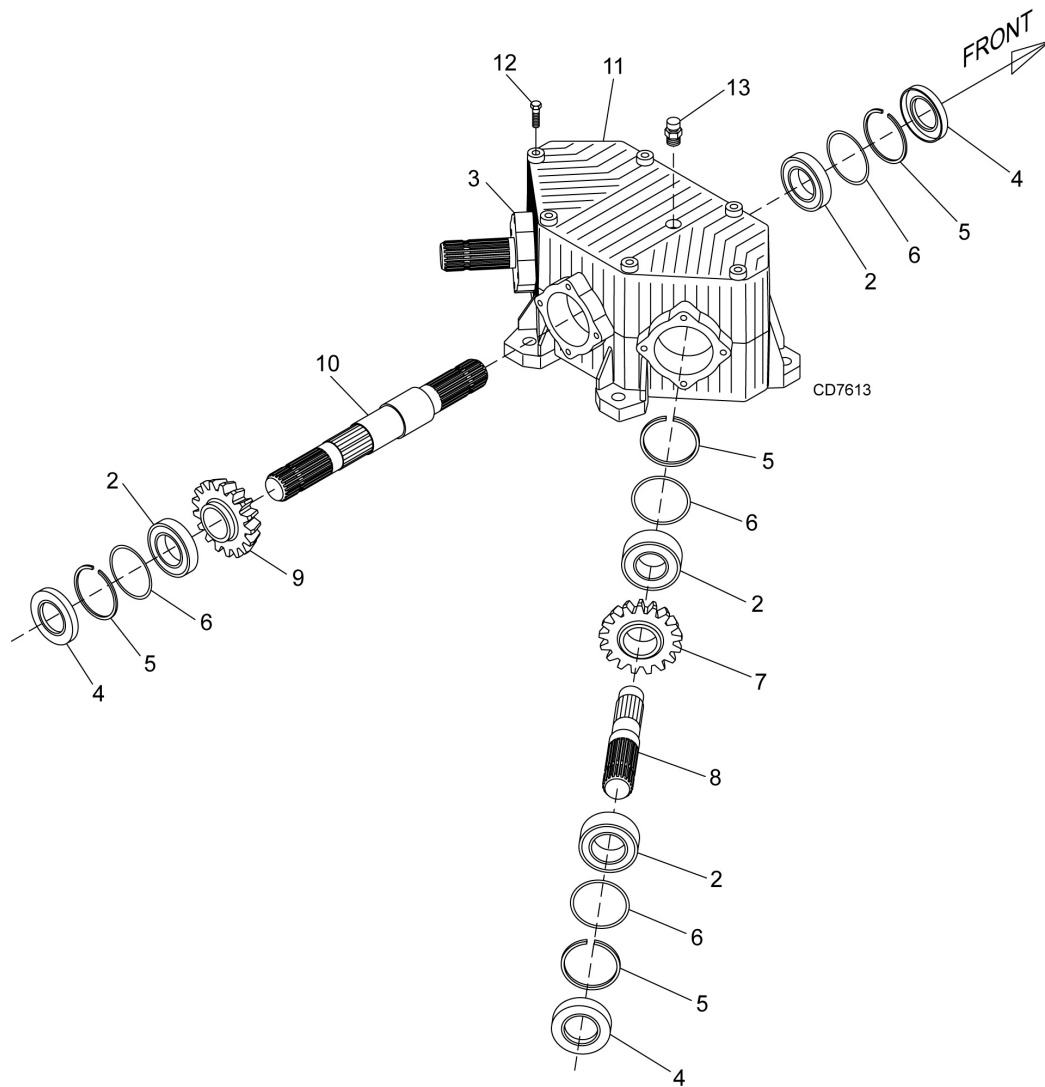

REF	PART 540 RPM	PART 1000 RPM	QTY	DESCRIPTION
1	1031185	1031186	-	Complete splitter gearbox
2	39411	39411	6	Bearing
3	-----	-----	1	Housing
4	1031175	1031175	4	Oil seal, 45mm x 85mm x 10mm
5	-----	-----	6	Snap ring 85 mm dia
6	57471	57471	6	Shim
7	1031176	-----	2	Pinion gear
8	-----	-----	2	Shaft 1-3/4 - 20 spline, wing
9	-----	1031176	1	Gear
10	1031179	1031179	1	Shaft 1-3/4 - 20 spline, center
11	-----	-----	1	Cover
12	-----	-----	*	M10 x 30mm HHCS CL8.8
13	57076	57076	1	1/2" breather

* Standard hardware, obtain locally

CENTER DECK DRIVE ASSEMBLY

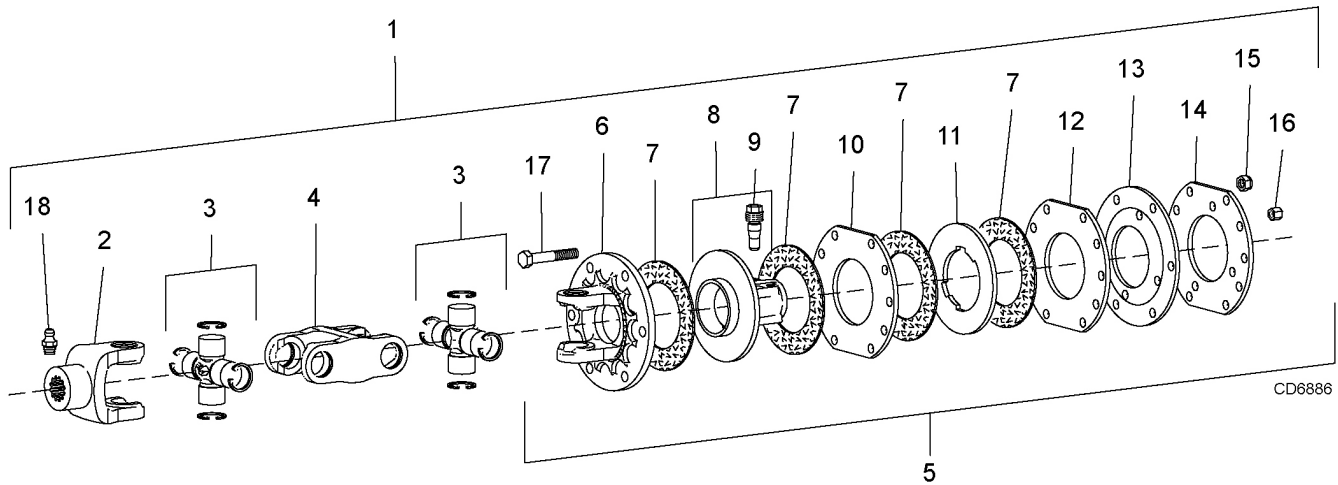

CD6886

REF	PART	QTY	DESCRIPTION
1	1045078	-	Complete center drive assembly
2	1019107	1	Yoke, 1-3/4, 20 spline
3	1045581	2	Cross & bearing kit
4	1019108	1	Double yoke
5	1016484	1	Friction clutch 2400 1-3/4, 20 spline (includes items 6 through 17)
6	1016489	1	Flange yoke
7	57432	4	Friction disc
8	1016490	1	Hub, 1-3/4, 20 spline (includes item 9)
9	1016498	1	Lock assembly
10	57443	1	Drive plate
11	1016491	1	Drive plate
12	1016494	1	Thrust plate
13	1016492	1	Belleville spring
14	-----	1	Backup plate
15	*	6	M12 x 1.75 hex lock nut w/ nylon insert
16	1016495	4	M8 x 1.25 hex nut GR10
17	1016496	6	M12 x 1.75 x 85 mm HHCS PC 8.8
18	1005521	1	Grease fitting
	*		Obtain Locally

WING DRIVE ASSEMBLY

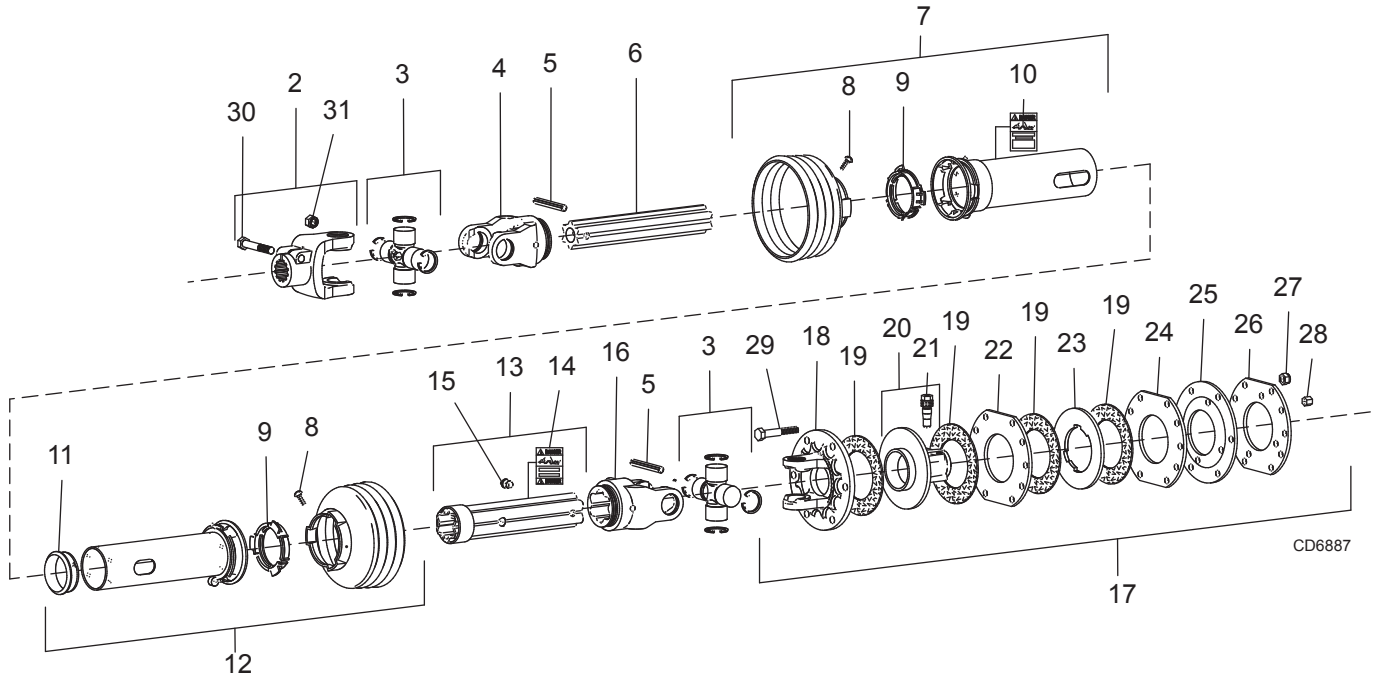

REF	PART	QTY	DESCRIPTION	REF	PART	QTY	DESCRIPTION
1	1045079	--	Complete wing drive assembly	17	1019109	1	Friction clutch 2500 1-3/4, 20 spline (includes items 18 through 29)
2	1004957	1	Yoke, 1-3/4, 20 spline (includes items 30, 31)	18	-----	1	Flange yoke
3	1045583	2	Cross & bearing kit	19	57432	4	Friction disc
4	40750	1	Inboard yoke	20	1016490	1	Hub, 1-3/4, 20 spline (includes item 21)
5	40765	2	Spring pin 10 x 90	21	1016498	1	Lock assembly
6	40752	1	Inner profile	22	57443	1	Drive plate
7	1045585	1	Outer guard half (includes items 8, 9, 10)	23	1016491	1	Drive plate
8	40778	2	Screw	24	1016494	1	Thrust plate
9	40766	2	Bearing ring SC25	25	1016492	1	Belleville spring
10	18864	1	Decal, danger rotating driveline	26	-----	1	Backup plate
11	40767	1	Support bearing	27	-----	6	M12 x 1.75 hex lock nut w/ nylon insert
12	1045586	1	Inner guard half (includes items 8, 9, 11)	28	1016495	4	M8 x 1.25 Hex nut GR10
13	-----	1	Outer profile & sleeve (includes items 14, 15)	29	1016496	6	M12 x 1.75 x 85 mm HHCS PC 8.8
14	33347	1	Decal, danger guard missing	30	1001042	1	M16 x 2.0 x 90 mm HHCS PC 8.8
15	40779	1	Grease fitting	31	-----	1	M16 x 2.0 Hex lock nut
16	40751	1	Inboard yoke				

CV DRIVE ASSEMBLY (WALTERSCHEID)

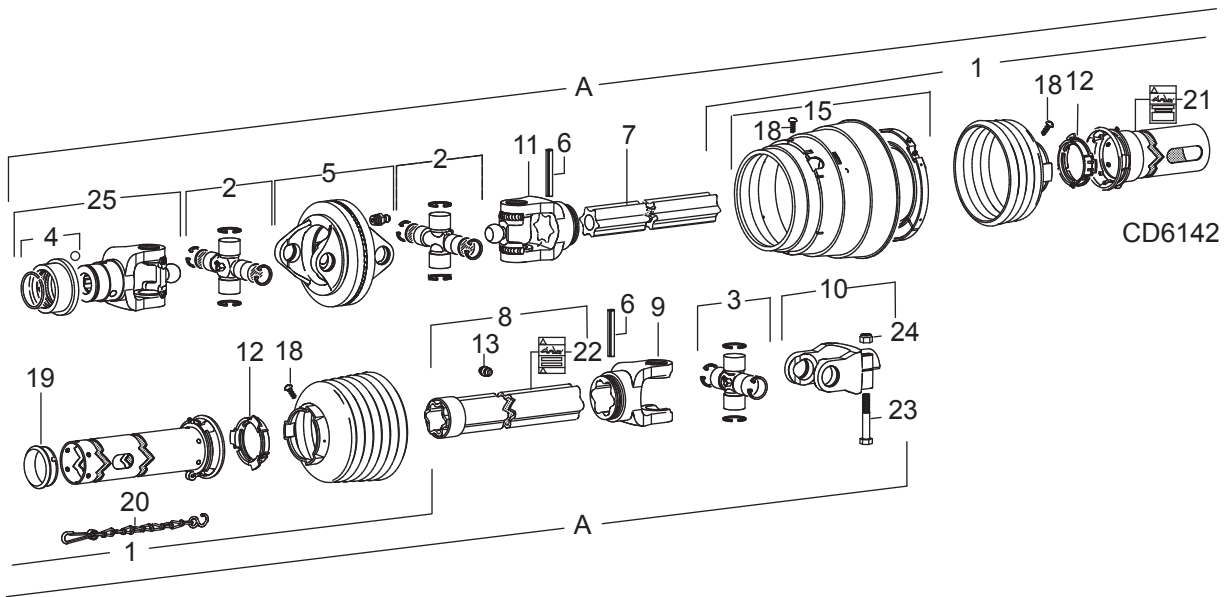

REF	540 1-3/8 6-SPLINED PART	1000 1-3/8 21-SPLINED PART	1000 1-3/4 20-SPLINED PART	QTY	DESCRIPTION
A	1021103	1021104	1021105	1	Complete CV drive
1	628893	628894	628895	1	Complete guard kit
2	628892	628892	628892	2	Cross & bearing kit
3	628891	628891	628891	1	Cross & bearing kit
4	629403	629403	629398	1	Slide collar repair kit
5	NSS	NSS	NSS	1	Double yoke
6	NSS	NSS	NSS	2	Spring pin 10 x 90 mm
7	NSS	NSS	NSS	1	Inner profile
8	NSS	NSS	NSS	1	Outer profile
9	NSS	NSS	NSS	1	Inboard yoke
10	NSS	NSS	NSS	1	Yoke, 1-3/4, 20 Spline
11	NSS	NSS	NSS	1	Inner yoke
12	NSS	NSS	NSS	2	Bearing ring
13	NSS	NSS	NSS	1	Grease fitting
15	NSS	NSS	NSS	1	Cone & bearing assembly
18	NSS	NSS	NSS	2	Screw
19	NSS	NSS	NSS	1	Support bearing
20	NSS	NSS	NSS	2	Anti-rotation chain
21	NSS	NSS	NSS	1	Decal, danger rotating driveline
22	NSS	NSS	NSS	1	Decal, danger guard missing
23	NSS	NSS	NSS	1	M16 x 2.0P x 90 mm HHCS PC8.8
24	NSS	NSS	NSS	1	M16 x 2.0P Hex lock nut w/nylon insert
25	NSS	NSS	NSS	1	Yoke
26	NSS	NSS	NSS	1	Outer guard half
27	NSS	NSS	NSS	1	Inner guard half
			NSS		Not Sold Separately

5-BOLT WHEEL & TIRE ASSEMBLY

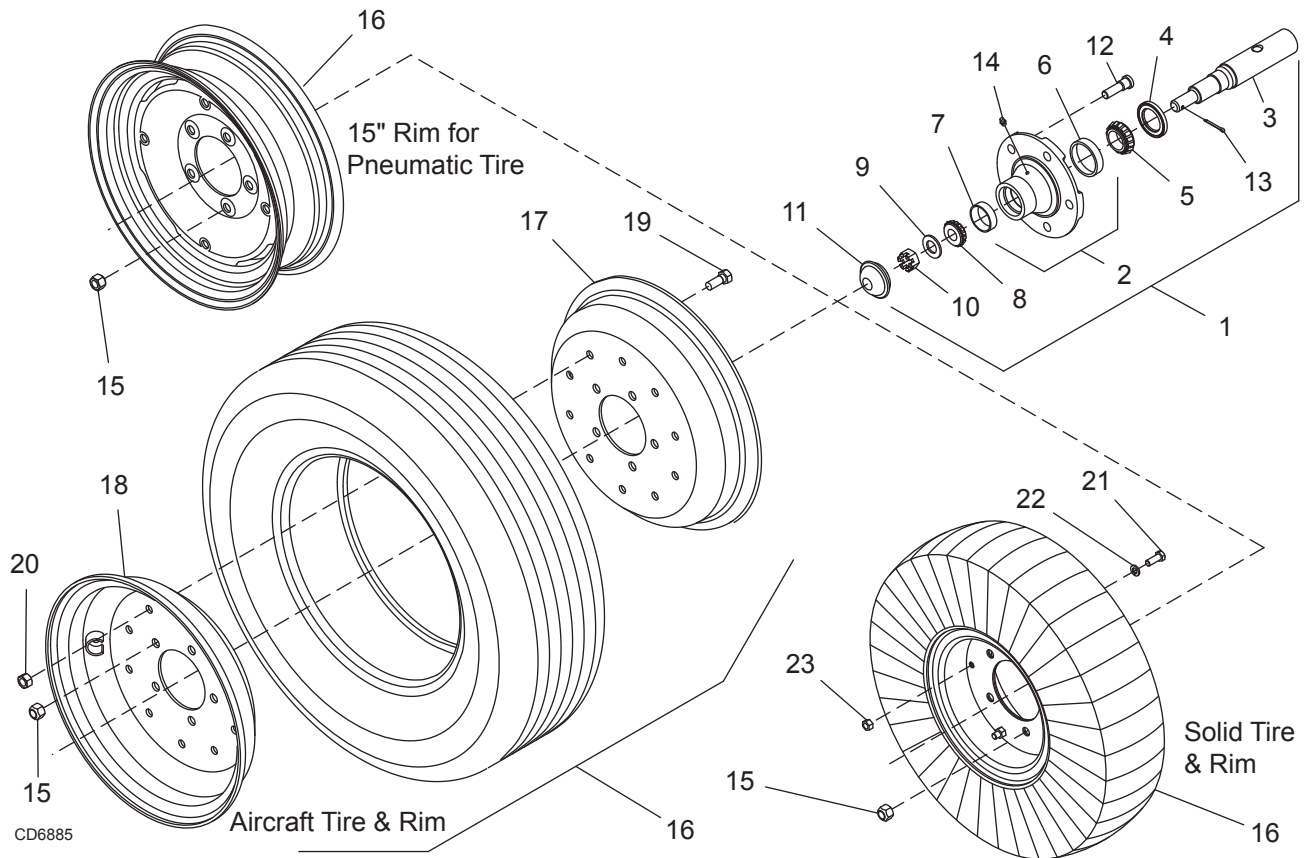

REF	PART	QTY	DESCRIPTION	REF	PART	QTY	DESCRIPTION
1	1017050	1	Heavy hub assembly (includes items 1 through 15)	16	1039976	1	25 x 8 - 14 Severe duty ag tire, rim & hardware - 5 bolt -OR-
2	1017034	1	Heavy wheel hub with cups (includes items 6,7,14)	16	1039976F	1	25 x 8 - 14 severe duty ag tire, rim & hardware, foam filled - 5 bolt
3	1017033	1	Axle	16	1017030	1	29 x 9 x 15 aircraft tire, rim & hardware - 5 bolt
4	1017027	1	Seal	17	1017026	1	15.0 x 6.0 rim half (for 29" aircraft wheel only)
5	1017028	1	Bearing cone	18	1017025	1	15.0 x 6.0 rim half w/ valve hole (for 29" aircraft wheel only)
6	1017036	1	Bearing cup	19	6100 *		1/2 NC x 1-1/4 HHCS GR5
7	2306	1	Bearing cup	20	765 *		1/2 NC lock nut
8	2304	1	Bearing cone	21	19887 *		3/8 NC x 1 HHCS GR8
9	1017031	1	Washer	22	838 *		3/8 standard lock washer
10	1017032	1	Castle nut	23	835 *		3/8 NC hex nut
11	1017035	1	Hub cap	-	1015833	1	29 x 9 x 15 inner tube (for 29" aircraft wheel only)
12	1017038	5	Stud	-	1017042	2	Rim half for 6 x 9 solid tire
13	1017069	1	Cotter				
14	1017067	1	Grease fitting				
15	35317	5	Nut, lug 1/2 NF				
16	1017088	1	15" rim for pneumatic tire - 5 bolt -OR-				
16	1017040	1	6.00 x 9 Solid tire, rim & hardware - 5 bolt -OR-				
							* Standard hardware, obtain locally

LIGHT KIT ASSEMBLY

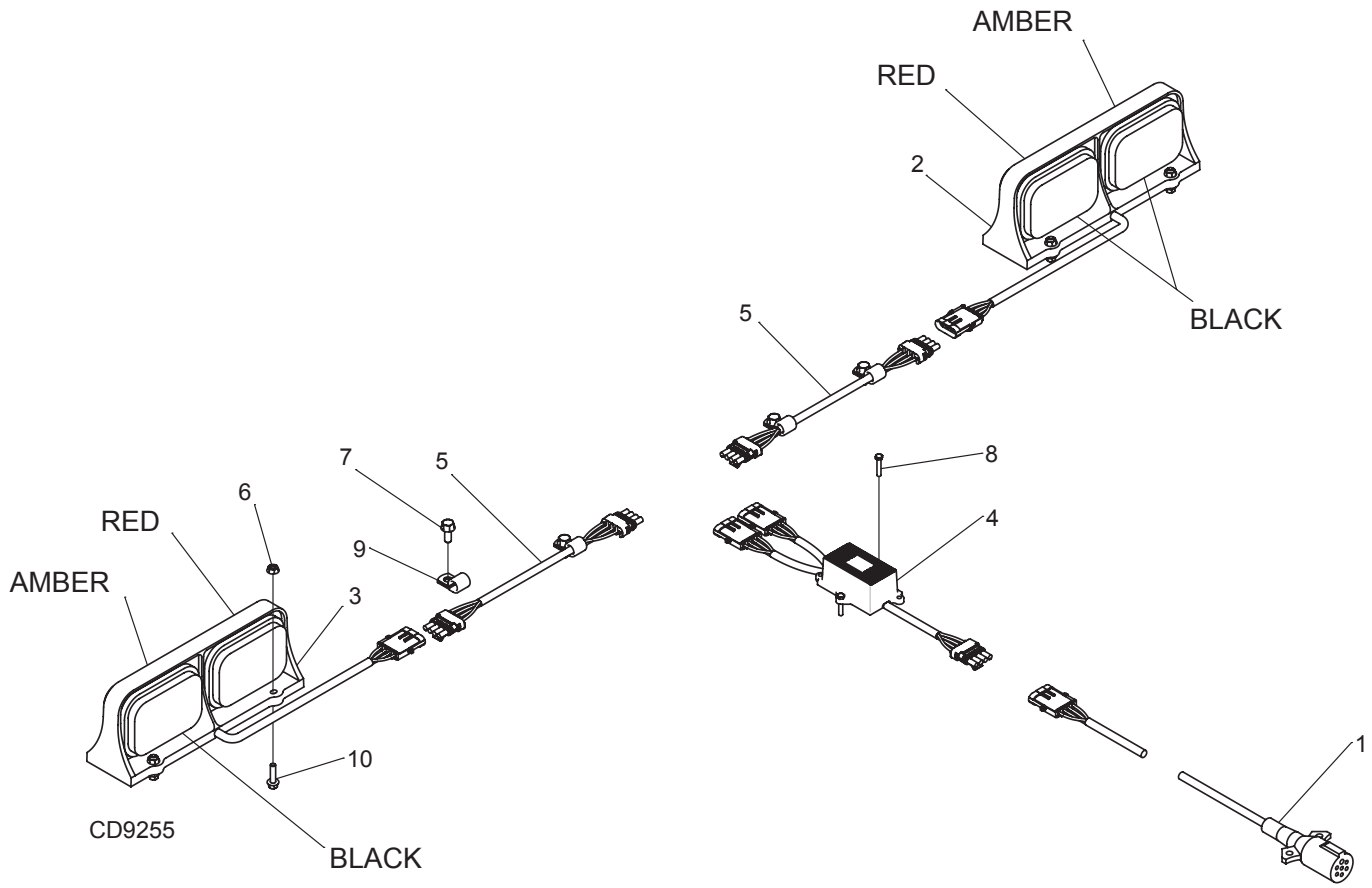

REF	PART	QTY	DESCRIPTION
1	1036887	1	WIRE HARNESS, 16 FT MAIN
2	1040275	1	LED AG COMBO LAMP LH
3	1040276	1	LED AG COMBO LAMP RH
4	1040277	1	AG ENHANCER MODULE
5	1045073	1	HARNESS, WIRE, 3 FT REAR, 2 PCS
6	62521	8	NUT LOCK 1/4 NC FLANGE
7	71851	4	BOLT, HEX FLNG 5/16 NC X .75 GR5
8	73540	2	SCREW MACHINE 10-24 X 1.00
9	78059	4	CLAMP .50 DIA STEEL CUSHION
10	1041087	8	SCREW, HFS-6 LOBE, 1/4 NCX1.0 GR5, PATCH

CHAIN SHIELDING - CENTER & WING (REAR)
SINGLE ROW STANDARD ON BW15.71 MODELS
DOUBLE ROW OPTIONAL ON BW15.71 MODELS

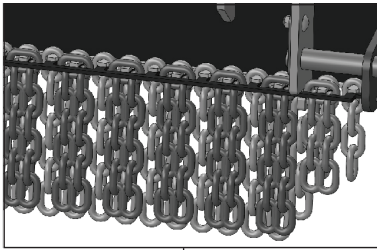
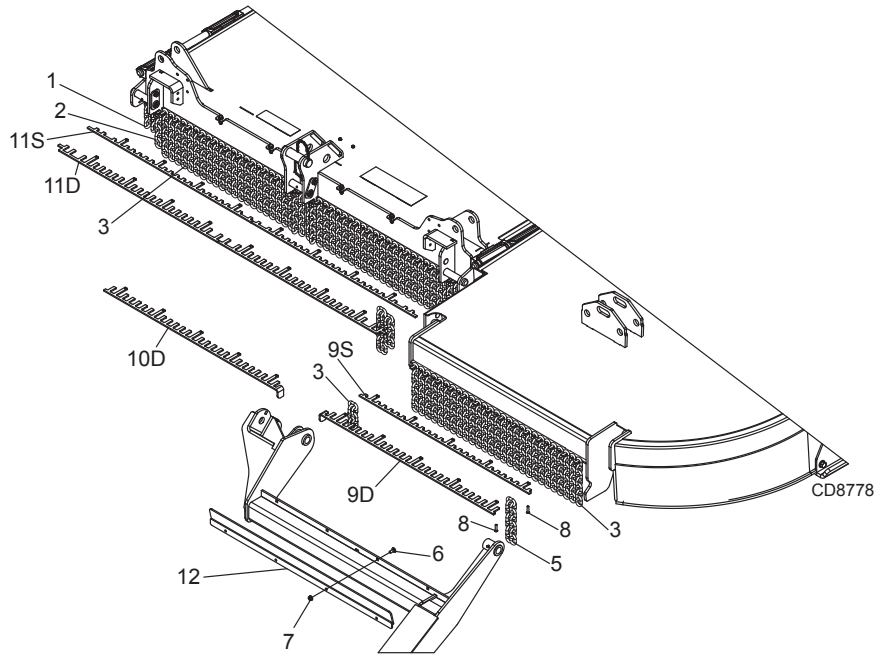

Rear Center Installed

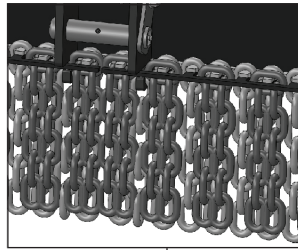

Rear Wing Installed

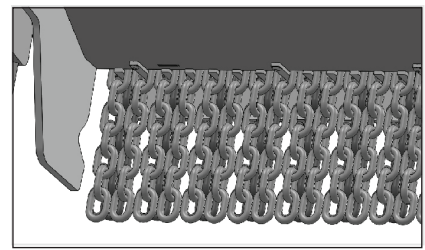

REF	PART	DESCRIPTION	QTY	
			DOUBLE	SINGLE
1	4069	5/16 chain 4 link	-	4
2	3994	5/16 chain 5 link	-	4
3	5496	5/16 chain 7 link	2	96
4	38381	5/16 chain 9 link	2	-
5	1016952	5/16 chain 13 link	50	-
6	16148	Bolt crg 5/16 NC x 3/4 ZP	8	-
7	1045655	Nut, HFN 5/16 NC, Dri-Loc patch	8	-
8	1041087	Screw, button head, 1/4 NC x 1.0, patch	18	18
9S	1044833RP	Link, chain, wing, RR	-	2
9D	1045677RP	Link, chain, wing, RR, DBL, RT	1	-
10D	-----	Link, chain, wing RR, DBL, LT	1	-
11S	1044855RP	Link, chain, center, RR	-	2
11D	1045678RP	Link, chain, center, RR, DBL	2	-
12	603898RP	WA, rear double chain flap	2	-

CHAIN SHIELDING - CENTER & WING (FRONT)

SINGLE ROW STANDARD ON BW15.71 MODELS

DOUBLE ROW OPTIONAL ON BW15.71 MODELS

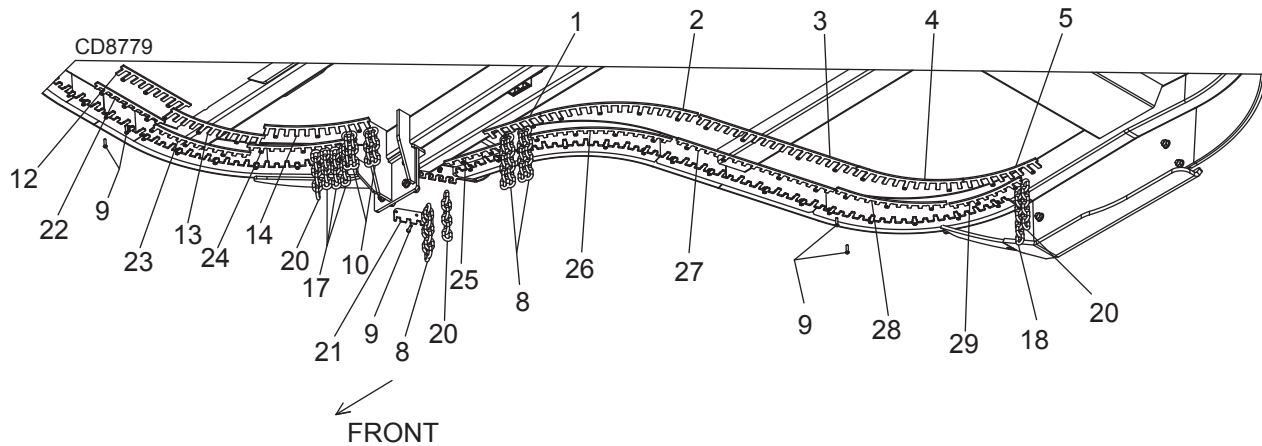

Front Center Installed

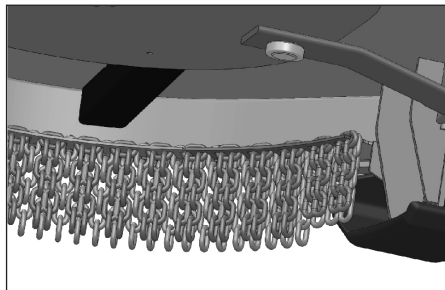

Wing Installed

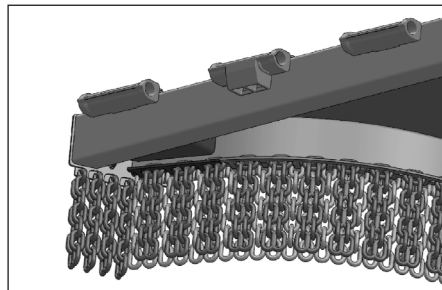

SINGLE ROW

DOUBLE ROW

REF	PART	QTY	DESCRIPTION	REF	PART	QTY	DESCRIPTION
9	1041087	70	1/4 NC x 1.0 button head screw	1	1045681RP	2	Straight winglet DBL retainer
16	4069	4	5/16 chain - 4 link	2	1045685RP	2	Curved winglet DBL retainer
17	3994	4	5/16 chain - 5 link	3	1045683RP	2	Front wing straight DBL chain retainer
18	5496	112	5/16 chain - 7 link	4	1045682RP	2	Front wing radius DBL chain retainer
20	5498	59	5/16 chain - 6 link	5	1045684RP	2	Front wing outer DBL chain retainer
21	1044996RP	2	Inner winglet retainer	7	1016953	25	5/16 chain - 11 link
22	1044858RP	1	Front center retainer	8	1016952	114	5/16 chain - 13 link
23	1044859RP	2	Front center inner radius retainer	10	38381	6	5/16 chain - 9 link
24	1045827RP	2	Front center outer radius retainer	12	1045679RP	1	Front center DBL retainer
25	1044861RP	2	Straight winglet retainer	13	1045680RP	2	Front center inner radius DBL retainer
26	1045075RP	2	Curved winglet retainer	14	1045838RP	2	Front center outer radius DBL retainer
27	1045039RP	2	Front wing straight chain retainer				
28	1044839RP	2	Front wing radius chain retainer				
29	1045074RP	2	Front wing outer chain retainer				

HYDRAULIC CYLINDERS (WING)

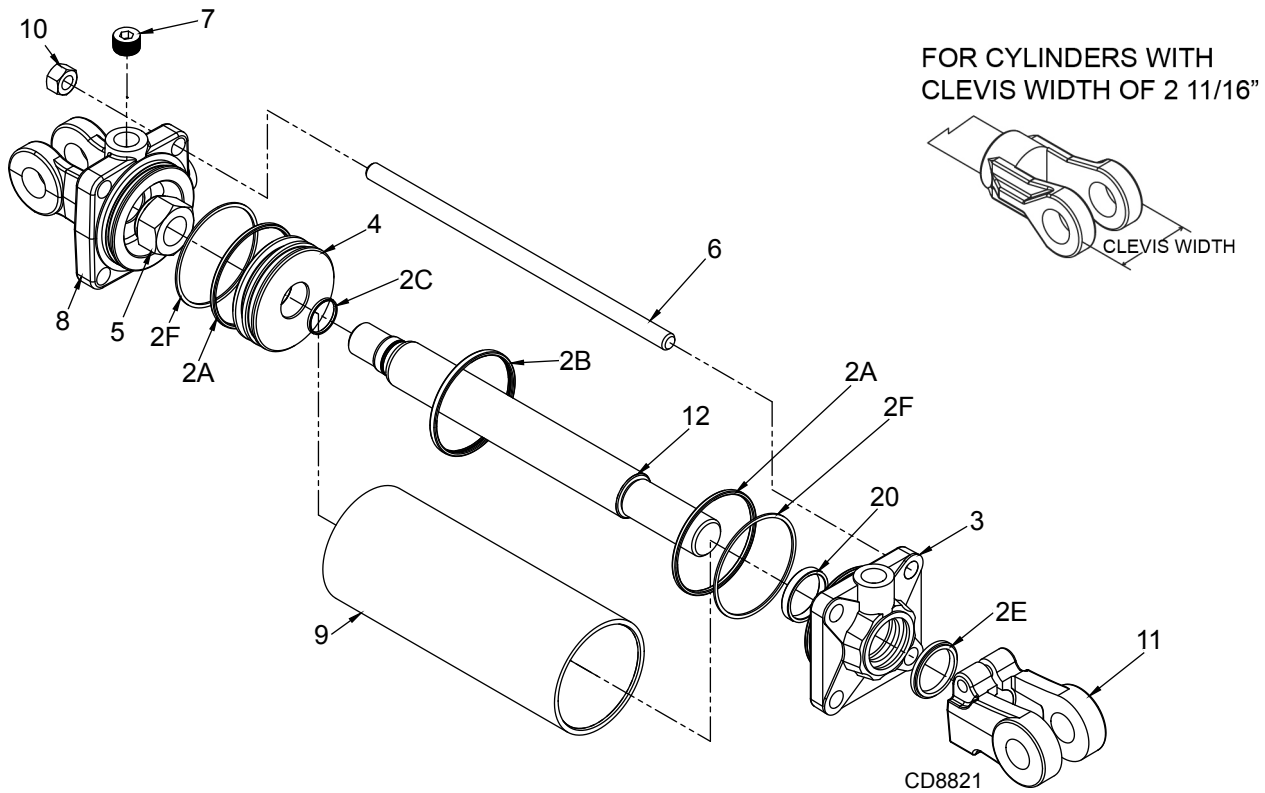

REF	3.0X1.25Ø ROD PART	QTY	DESCRIPTION
1	597269		Complete cylinder
2	600251	1	Seal kit (includes items 2A-2F)
2A	†	2	Cap o-ring
2B	†	1	Pistol seal
2C	†	1	Rod o-ring
2D	†	1	Cap seal
2E	†	1	Wiper seal
2F	†	2	Backup seal
3	N/S	1	Cylinder housing rod end
4	N/S	1	Piston
5	N/S	1	Jam nut
6	N/S	4	Cylinder tie rod
7	*	3	1/2 pipe plug
8	N/S	1	Cylinder housing butt end
9	N/S	1	Cylinder barrel
10	N/S	8	Tie rod nut
11	N/S	1	Cylinder clevis
12	N/S	1	Cylinder rod

† Included in seal kit

* Standard hardware, obtain locally

N/S Not serviced

HYDRAULIC CYLINDER (CENTER)

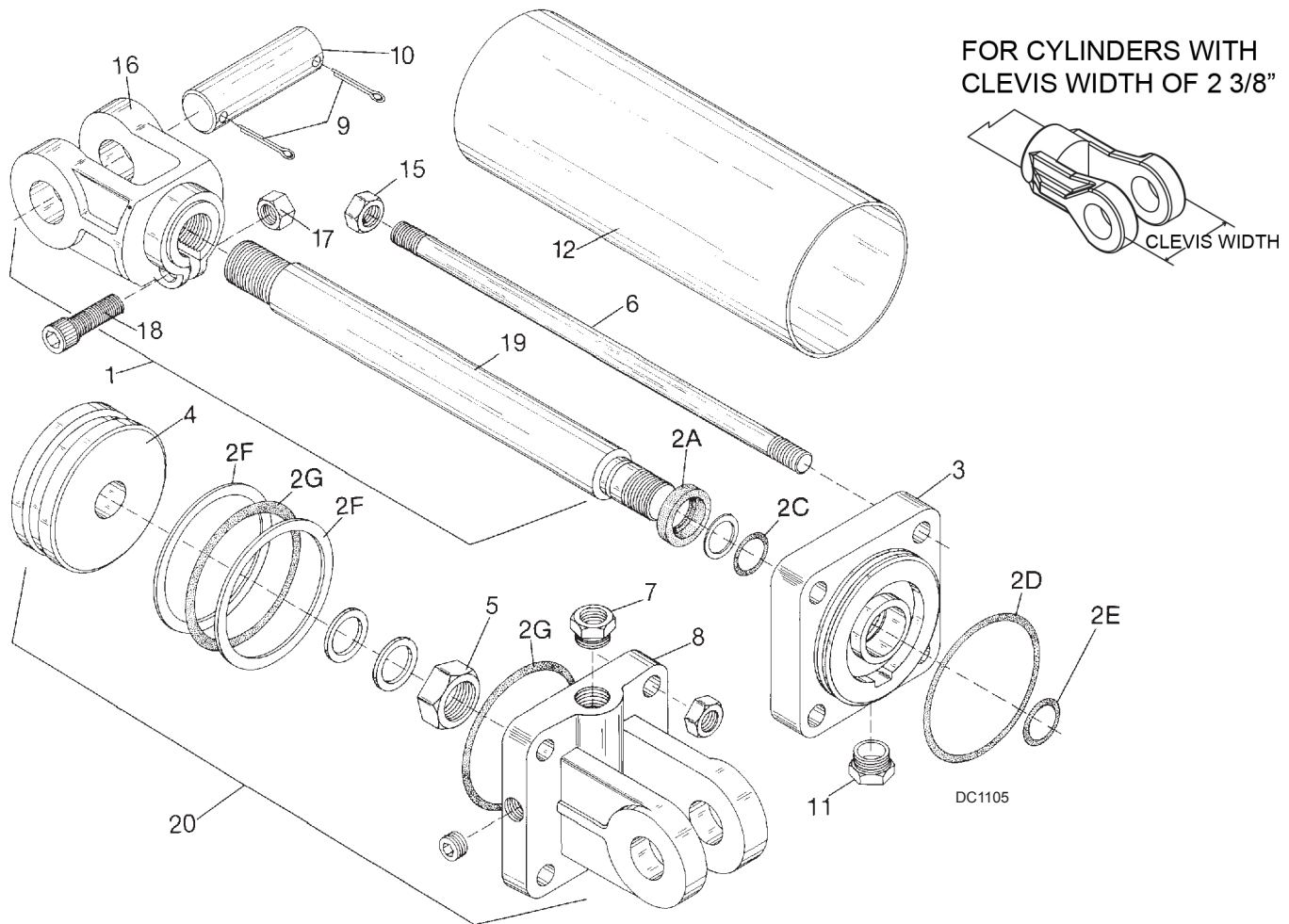

FOR CYLINDERS WITH
CLEVIS WIDTH OF 2 3/8"

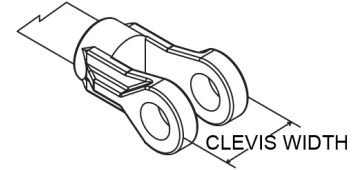

DC1105

REF	CENTER 3.5 X 8 PART	QTY	DESCRIPTION	REF	CENTER 3.5 X 8 PART	QTY	DESCRIPTION
2	23540	1	Seal repair kit (includes 2A - 2G)	11	11975	1	1/2 NPT vent plug
2	-----	1	Seal repair kit w/ heavy duty piston seal (includes 2A - 2G)	12	NS	1	Cylinder barrel
2A	‡	1	Wiper seal	15	*	8	Tie rod nut
2C	‡	2	1-1/4 ID u-cup	16	23549	1	Hydraulic cylinder rod clevis
2D	‡	2	Barrel o-ring	17	6698*	1	3/8 NC lock nut
2E	†		Rod static o-ring	18	-----*	1	3/8 NC x 1-1/2 socket head cap screw
2F	‡	2	Piston back-up washer	19	23551	1	Hydraulic cylinder rod
2G	‡	1	Pistol seal o-ring	20	-----	1	3 x 10 hydraulic cylinder - wing
3	-----	1	Rod end housing	20	10475	1	3-1/2 x 8 hydraulic cylinder w/ breather complete
4	-----	1	Piston				
5	25496	1	Jam nut		*		Obtain locally
6	NS	4	Cylinder tie rid		†		Not used on this cylinder
7	W11893*	1	1/2 x 1/4 pipe reducer bushing		‡		Included in seal kit
8	NS	1	Cylinder butt end		NS		Not sold separately
9	923*	1	4 1/4 x 1-3/4 cotter pin				
10	1631	2	1 x 3-5/8 clevis pin				

HYDRAULIC CYLINDER STROKE CONTROL KIT

REF	PART	QTY	DESCRIPTION
1	24098A	1	Stroke control set for 1-1/4" cylinder rod (contains items 2 - 5)
2	-----	2	1-1/2" Segment
3	-----	1	1-1/4" Segment
4	-----	1	1" Segment
5	-----	1	3/4" Segment

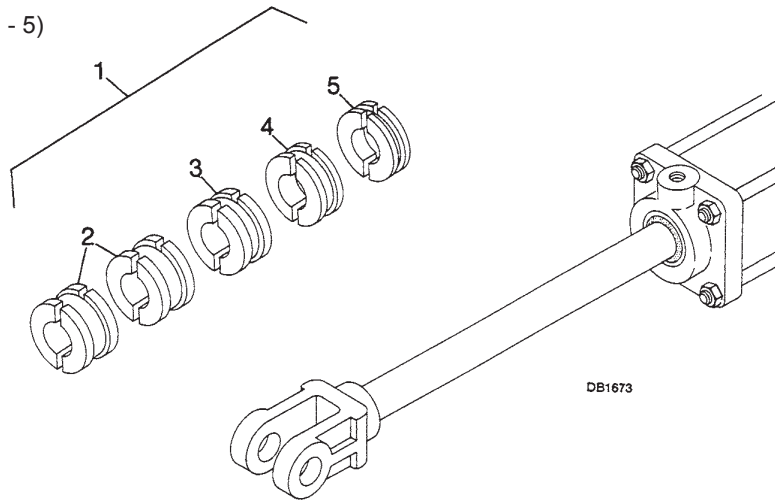

CROSSBAR PULLER (OPTIONAL)

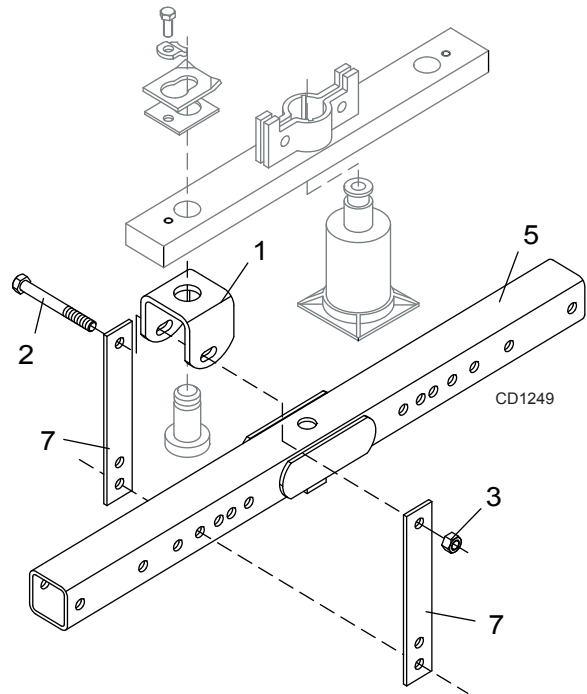
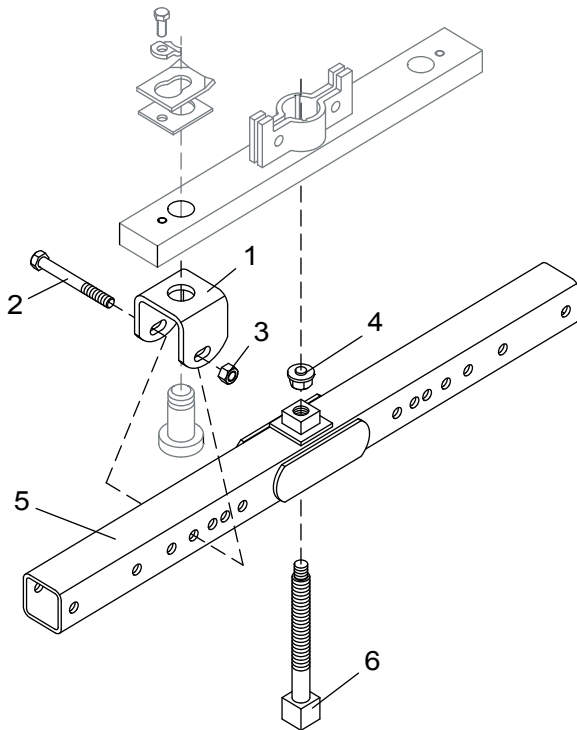

REF	PART	QTY	DESCRIPTION
A	8811	1	Crossbar puller, complete
1	-----	2	Crossbar puller clevis
2	3097 *	4	5/8 NC x 4-1/2 HHCS GR5
3	230 *	4	5/8 NC hex nut

REF	PART	QTY	DESCRIPTION
4	-----	1	Crossbar puller pad assembly
5	24876	1	Crossbar puller tube assembly
6	24881	1	Crossbar puller screw assembly
7	24885RP	4	Crossbar puller link

* Standard hardware, obtain locally

BW10.71 / BW10.71Q WEIGHT BOX ASSEMBLY

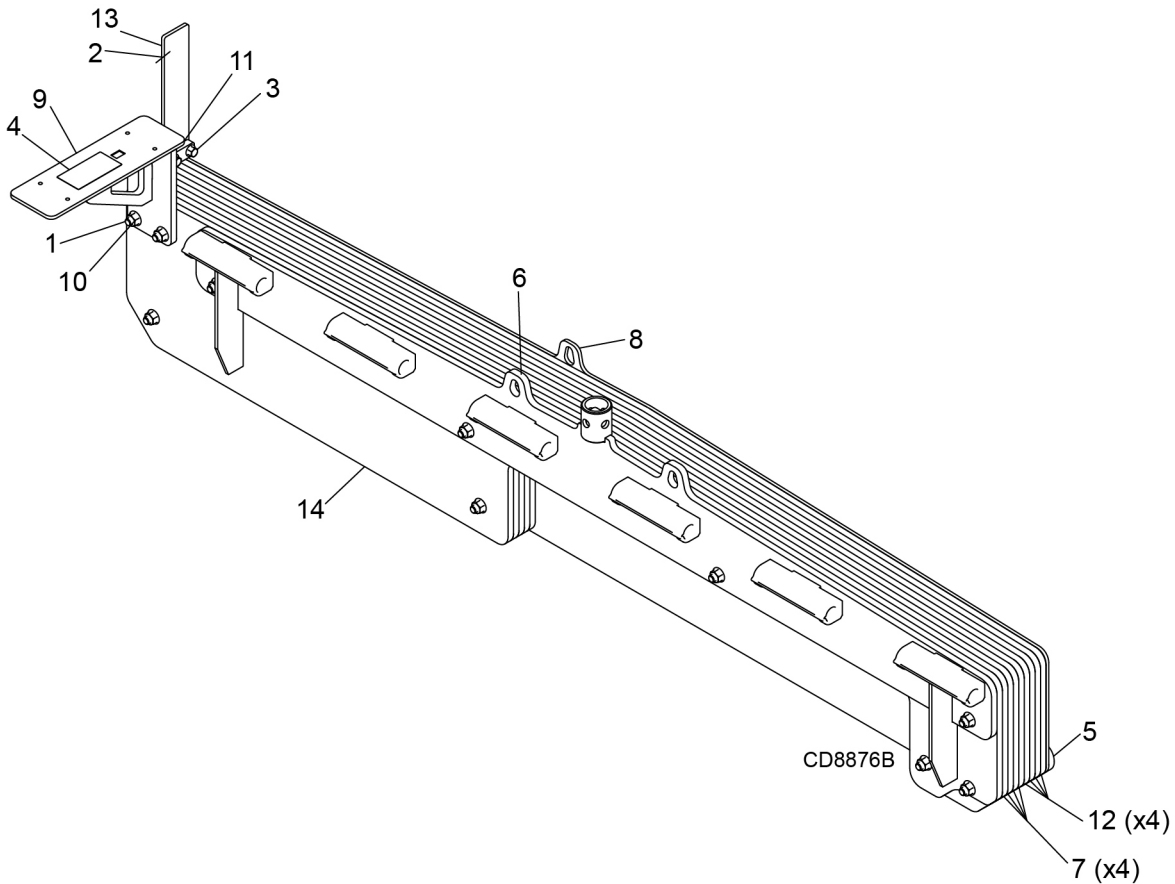

REF	PART	QTY	DESCRIPTION
1	13563	10	HHCS 1/2 NC x 6 GR5
2	57123	1	Decal 2 x 9 rear reflector
3	1033958	2	Screw .375NC x 1 - .25 hex flange ser
4	1041910	1	Decal, NOTICE light kit
5	1045084RP	1	Plate, weight box
6	1045088RP	1	WA, weight box hinge
7	1045090RP	4	Plate, weight box inner
8	1045091RP	1	Plate, weight box outer
9	1045095RP	1	WA, weight box mount
10	1045624	10	Nut, HFN 1/2 NC, Dri-Loc patch
11	1045628	2	Nut, HFN 3/8 NC, Dri-Loc patch
12	1045879RP	4	Plate, weight box inner 70
13	1045883RP	1	Lug, weight box reflector
14	1046095RP	1	Plate, weight box inner notch

HHCS Hex Head Cap Screw

WINCH KIT (OPTIONAL)

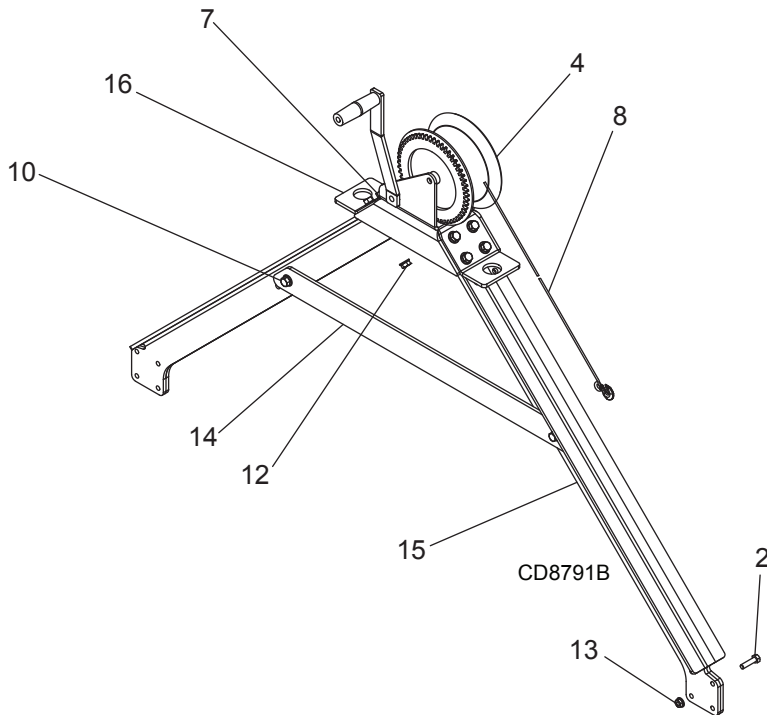

REF	PART	QTY	DESCRIPTION
A	1045853	-	Winch kit, complete
1	409	2	1/2 x 2 clevis pin
2	6250	8	HHCS 5/16 NX x 1/1/4 GR5 ZP
3	6696	2	Chain idler castings
4	12612	1	Winch, gear 20 5.1 to 1
5	22411	2	3/16 x 1 klik pin
6	-----	4	Link bent .25 x 1.5 x 4.50
7	62153	11	Screw .375 NX x 1 hex flng ser
8	603801	1	Cable, 3/16 x 25 ft, hook
9	1031225	8	HFS .50 NC x 1.25 GR5
10	1033958	2	Screw .375 NC x 1 -.25 Hex flng ser
11	1045624	8	Nut, HFN 1/2 NC, Dri-Loc patch
12	1045628	13	Nut, HFN 3/8 NC, Dri-Loc patch
13	1045655	8	Nut, HFN 5/16 NC, Dri-Loc patch
14	1045856RP	1	Link, winch tie
15	1045858RP	2	WA, winch tie
16	1045859RP	1	Channel, winch mount
	N/S		Not serviced

Winch Kit Installation

1. Locate and drill one 9/16" hole in each wing as shown. Assemble items 6, 3, 1 and 5 and use to locate and drill remaining holes.
2. Secure idler brackets (6) and rollers (3) to deck with bolts (9) and nuts (11).
3. Assemble uprights to inside of rear ctr frame using bolts (2) and nuts (13).
4. Assemble winch assembly to uprights (4) using bolts (7) and lock nuts (12).
5. Tighten all hardware.

Winch Kit Operation

1. Move cutter so wing is on the up slope of a ditch to aid in wing lift with the winch.
2. Unwind cable and remove roller (14).
3. Place cable around roller (14) and reinstall using pin (12) and Klik pin (13).
4. Connect C-Hook (8) to winch mount (2).
5. Remove cylinder pin from clevis end and raise slowly with winch.
6. Install transport lock before moving unit.

TANDEM AXLE (OPTIONAL)

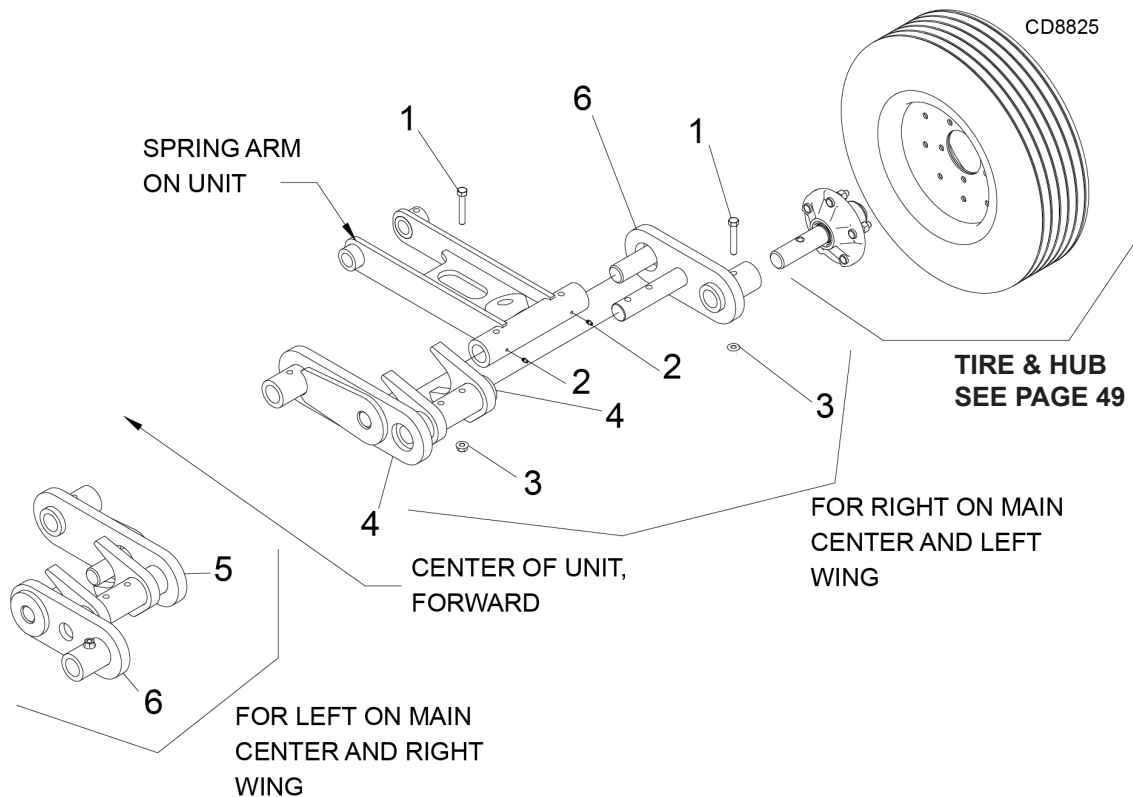

Tandem Axle Installation

1. Raise unit and support with jack stands per diagram page 20 to take pressure from tires.
2. Remove wheel assembly from right spring arm hub assembly from center frame.
3. Remove axle hub from right spring arm.
4. Install drive type grease fitting in four holes in spring arm.
5. Install tandem arm 1045738 as shown.
6. Install tandem arm 1045739 as shown, sliding both axles into receiving tubes. Fasten with screws 3489 and nuts 1045624 provided.
7. Install axle / hub 1017050 and secure with screw 3489 and nut 1045624, reused or purchased separately as needed.
8. Install wheel assembly.
9. Repeat for left spring arm of center frame, using 1045850 in place of 1045738, installed from the center.
10. Repeat for wings if purchased, noting orientation of parts to locate wheels in the correct position. Outer wheel should be forward of inner wheel on both wings.

BEFORE SERIAL NO. 10007668087004

REF	PART	QTY	DESCRIPTION
1	3489	8	HHCS 1/2 NC x 3 GR5 ZP
2	1043432	8	Zerk, 1/4 drive type
3	1045624	8	Nut, HFN 1/2 NC, Dri-Loc patch
4	1045738RP	1	WA, tandem arm, RT
5	1045739RP	1	WA, tandem arm, LT
6	1045850RP	2	WA, tandem arm

AFTER SERIAL NO. 10007668087004

REF	PART	QTY	DESCRIPTION
1	3489	8	HHCS 1/2 NC x 3 GR5 ZP
2	1043432	8	Zerk, 1/4 drive type
3	1045624	8	Nut, HFN 1/2 NC, Dri-Loc patch
4	617126RP	1	WA, tandem arm, RT
5	617127RP	1	WA, tandem arm, LT
6	1045850RP	2	WA, tandem arm

SHRED KIT (OPTIONAL)

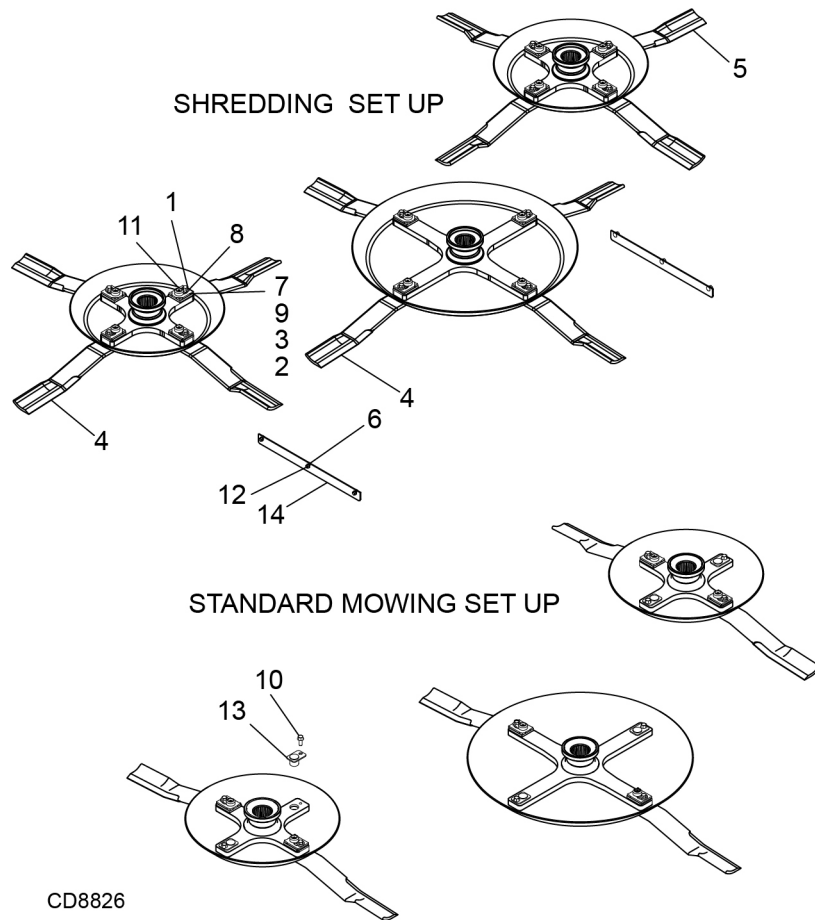

CD8826

Installation Instructions

1. Install supplied shred kit blades as shown, using shims to obtain no more than .25" movement at blade tip. Stack shims as shown on page 21.
2. Install baffle extensions 1045884 with supplied hardware onto front wing baffles.

To Return Batwing® to Brush Cutting

1. Remove baffles.
2. Remove one opposing set of blades and hardware from each crossbar.
3. To protect unused hole for following season: coat tab pin into hole and secure with screw 1031225.
4. For lower horsepower shredding, remove baffle extensions. For extremely low horsepower shredding, order 3 sets of flat double edge blade kits 19162KT.

REF	PART	QTY	DESCRIPTION
1	3379	6	HHCS 1/2 NC x 1-1/2 GR5 ZP
2	10520RP	6	18 GA 1-1/2 blade pin shim
3	13946RP	6	20 GA 1-1/2 blade pin shim
4	19160KT	4	Blade, .50 x 4 x 25 CCW FRMD, kit
5	19161KT	2	Blade, .50 x 4 x 2.5 CW FRMD, kit
6	24597	6	Carriage bolt 3/8 NC x 3/4
7	32603	6	Keyhole plate special
8	32604RP	6	Blade pin lock clip spec
9	1028824RP	6	Spacer, 5/16 thick blade pin
10	1031225	6	HFS .50 NC x 1.25 GR5
11	1045034RP	6	Pin, blade, DRL, 2.39
12	1045628	6	Nut, HFN 3/8 NC, Dri-Loc patch
13	1045820	6	WA, pin 1.50 x 1.13
14	1045884RP	2	Lug, shred baffle
15	19162KT	3	Blade, .50 x 4 x 25 flat double edge blade kit, optional for low horsepower shredding (NS)

NS Not shown

BOLT TORQUE CHART

Always tighten hardware to these values unless a different torque value or tightening procedure is listed for a specific application.

Fasteners must always be replaced with the same grade as specified in the manual parts list.

Always use the proper tool for tightening hardware: SAE for SAE hardware and Metric for metric hardware. Make sure fastener threads are clean and you start thread engagement properly.

All torque values are given to specifications used on hardware defined by SAE J1701 MAR 99 & J1701M JUL 96.

SAE SERIES TORQUE CHART

SAE Bolt Head Identification

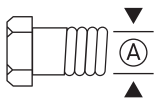

SAE Grade 2
(No Dashes)



SAE Grade 5
(3 Radial Dashes)



SAE Grade 8
(6 Radial Dashes)

Ⓐ Diameter (Inches)	Wrench Size	Marking on Head					
		SAE 2		SAE 5		SAE 8	
		lbs-ft	N-m	lbs-ft	N-m	lbs-ft	N-m
1/4"	7/16"	6	8	10	13	14	18
5/16"	1/2"	12	17	19	26	27	37
3/8"	9/16"	23	31	35	47	49	67
7/16"	5/8"	36	48	55	75	78	106
1/2"	3/4"	55	75	85	115	120	163
9/16"	13/16"	78	106	121	164	171	232
5/8"	15/16"	110	149	170	230	240	325
3/4"	1-1/8"	192	261	297	403	420	569
7/8"	1-5/16"	306	416	474	642	669	907
1"	1-1/2"	467	634	722	979	1020	1383

TYPICAL WASHER INSTALLATIONS

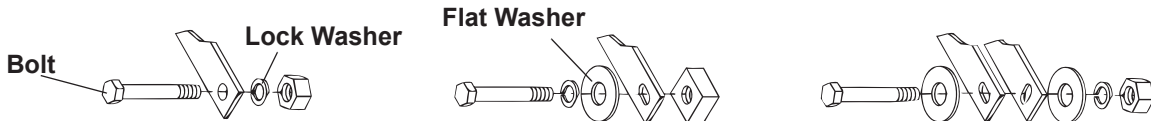

METRIC SERIES TORQUE CHART

Metric Bolt Head Identification

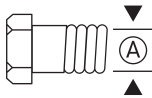

Metric
Grade 8.8



Metric
Grade 10.9

Ⓐ Diameter & Thread Pitch (Millimeters)	Wrench Size	Coarse Thread				Fine Thread				Ⓐ Diameter & Thread Pitch (Millimeters)
		Marking on Head								
		Metric 8.8		Metric 10.9		Metric 8.8		Metric 10.9		
		N-m	lbs-ft	N-m	lbs-ft	N-m	lbs-ft	N-m	lbs-ft	
6 x 1.0	10 mm	8	6	11	8	8	6	11	8	6 x 1.0
8 x 1.25	13 mm	20	15	27	20	21	16	29	22	8 x 1.0
10 x 1.5	16 mm	39	29	54	40	41	30	57	42	10 x 1.25
12 x 1.75	18 mm	68	50	94	70	75	55	103	76	12 x 1.25
14 x 2.0	21 mm	109	80	151	111	118	87	163	120	14 x 1.5
16 x 2.0	24 mm	169	125	234	173	181	133	250	184	16 x 1.5
18 x 2.5	27 mm	234	172	323	239	263	194	363	268	18 x 1.5
20 x 2.5	30 mm	330	244	457	337	367	270	507	374	20 x 1.5
22 x 2.5	34 mm	451	332	623	460	495	365	684	505	22 x 1.5
24 x 3.0	36 mm	571	421	790	583	623	459	861	635	24 x 2.0
30 x 3.0	46 mm	1175	867	1626	1199	1258	928	1740	1283	30 x 2.0

BOLT SIZE CHART

NOTICE: Chart shows bolt thread sizes and corresponding head (wrench) sizes for standard SAE and metric bolts.

SAE BOLT THREAD SIZES

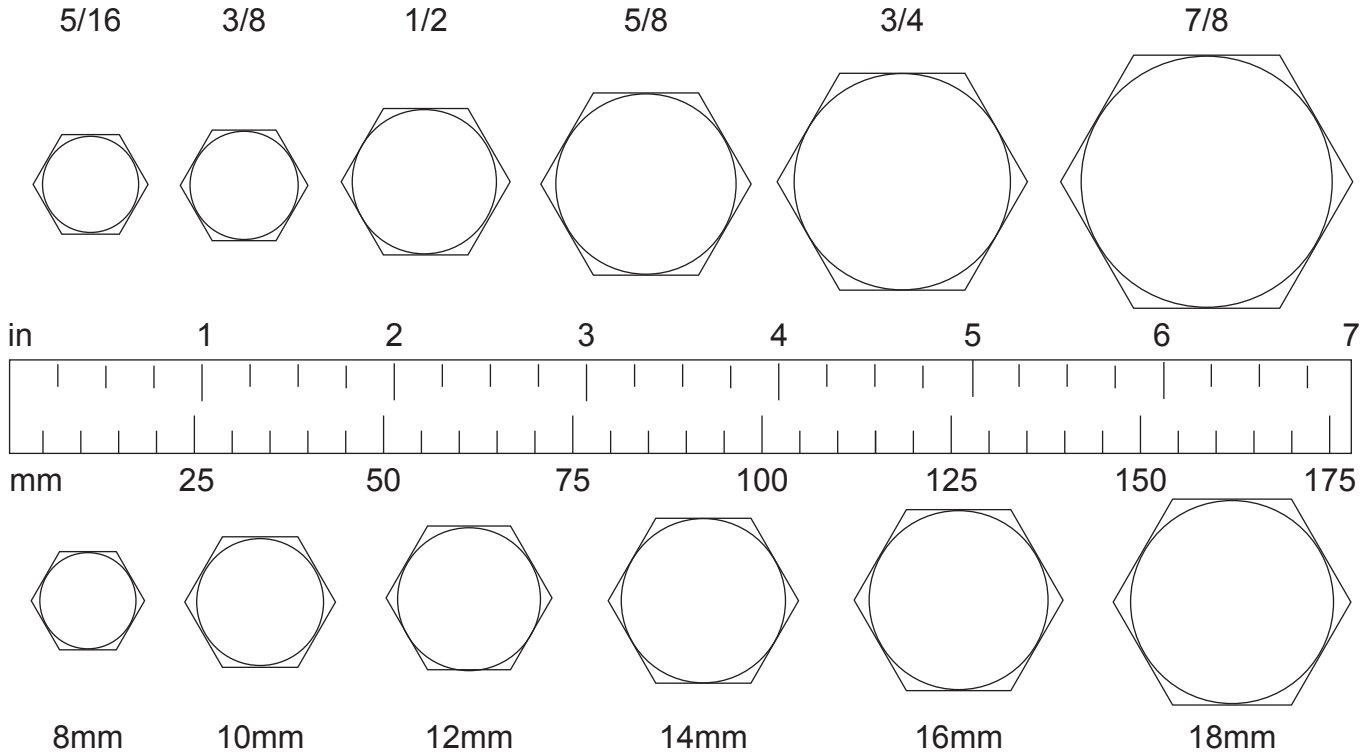

METRIC BOLT THREAD SIZES

ABBREVIATIONS

AG Agriculture	HT Heat-Treated	ORBM O-Ring Boss - Male
ASABE American Society of Agricultural & Biological Engineers (formerly ASAE)	JIC Joint Industry Council 37° Degree Flare	P Pitch
ASAE American Society of Agricultural Engineers	LH Left Hand	PBY Power-Beyond
ATF Automatic Transmission Fluid	LT Left	psi Pounds per Square Inch
BSPP British Standard Pipe Parallel	m Meter	PTO Power Take Off
BSPTM British Standard Pipe Tapered Male	mm Millimeter	QD Quick Disconnect
CV Constant Velocity	M Male	RH Right Hand
CCW Counter-Clockwise	MPa Mega Pascal	ROPS Roll-Over Protective Structure
CW Clockwise	N Newton	RPM Revolutions Per Minute
F Female	NC National Coarse	RT Right
FT Full Thread	NF National Fine	SAE Society of Automotive Engineers
GA Gauge	NPSM National Pipe Straight Mechanical	UNC Unified Coarse
GR (5, etc.) Grade (5, etc.)	NPT National Pipe Tapered	UNF Unified Fine
HHCS Hex Head Cap Screw	NPT SWF National Pipe Tapered Swivel Female	UNS Unified Special

INDEX

ADJUSTMENTS

- Cutting Height 15
- Slip Clutch 22

ASSEMBLY

- Dealer Set-Up Instructions 33

DEALER CHECKLIST

- Checklists
 - Delivery (Dealer's Responsibility) 35
 - Pre-Delivery (Dealer's Responsibility) 35

DEALER SERVICE

- Crossbar
 - Installation 31
 - Removal 30
- Gearbox Maintenance
 - Seal Installation 25
 - Seal Replacement 25
 - Horizontal Shaft 26
 - Vertical Shaft 26
- Gearbox Repair
 - Assembly 26
 - Disassembly 26
 - Reinstallation 27
 - Removal 26
- Splitter Gearbox Repair
 - Assembly 28
 - Check Gearbox for Leaks 29
 - Disassembly 28
 - Reinstallation 29
 - Removal from Cutter 28
- Universal Joint
 - Assembly 32
 - Disassembly 31
 - Repair 31

GENERAL

- Abbreviations 62
- Bolt Size Chart 62
- Bolt Torque Chart 60
- General Information 4
- Introduction 2
- Obtaining Replacement Manuals 2
- Product Registration 2
- Specifications 4
- Table of Contents 3

OPERATION

- Connecting Cutter to Tractor 14
 - Cutting Height Adjustment 15
 - CV Driveline Turning Limits 15
 - Hydraulic Connection 15
 - Interference Check 15
- Cutter Operation 16
 - Mowing Tips 16
 - Shredding 16
- Pre-Operation Checklist (Owner's Responsibility) 18
- Storage 18
- Tractor Operation 16
- Transporting 17
 - Lock-Up 17
 - Center Section 17
 - Wing 17

OWNER SERVICE

- Adjusting Slip Clutch 22
- Blades
 - Installation 21
 - Removal 21
 - Sharpening 22
- Blocking Method 19
- Lubrication
 - Driveline 20
 - Gearbox 20
 - Lubrication Points 20
 - Seasonal 21
- Shielding Repair 23
- Slip Clutch Adjustment 22

PARTS

- Parts Index 36

SAFETY

- Blocking Method 19
- Checklists
 - Delivery Checklist (Dealer's Responsibility) 35
 - Pre-Delivery Checklist (Dealer's Responsibility) 35
 - Pre-Operation Checklist (Owner's Responsibility) 18
- Online Safety Video 5, 6
- Safety & Instructional Decals 11, 12, 13
- Safety Rules 7, 8, 9, 10
- Safety Symbols Explained 2

TROUBLESHOOTING 24

PART NO.
MAN1339

WOODS®

2606 South Illinois Route 2
Post Office Box 1 000
Oregon, Illinois 61061 USA

800-319-6637 tel
800-399-6637 fax
woodsequipment.com



© 2023 Woods Equipment Company. All rights reserved. Woods® and the Woods logo are trademarks of Woods Equipment Company. All other trademarks, trade names, or service marks not owned by Woods Equipment Company that appear in this manual are the property of their respective companies or mark holders. Specifications subject to change without notice.