

BATWING[®] ROTARY CUTTER BW10.30

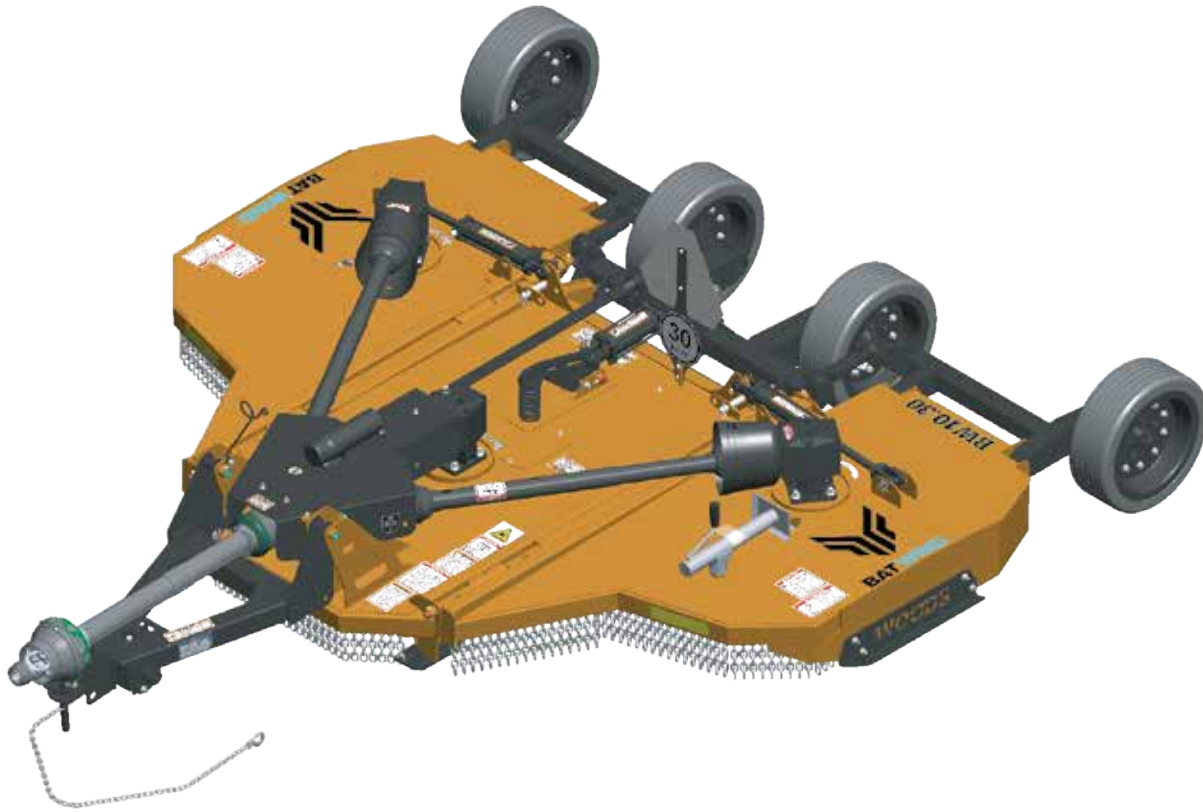

MAN1405
(Rev 04/29/2026)

WOODS[®]

OPERATOR'S MANUAL

TO THE DEALER:

Assembly and proper installation of this product is the responsibility of the Woods® dealer. Read manual instructions and safety rules. Make sure all items on the Dealer's Pre-Delivery and Delivery Checklists in the Operator's Manual are completed before releasing equipment to the owner.

The dealer must complete the online Product Registration form at the Woods Dealer Website which certifies that all Dealer Checklist items have been completed. Dealers can register all Woods product at dealer.WoodsEquipment.com under Product Registration.

Failure to register the product does not diminish customer's warranty rights.

TO THE OWNER:

Read this manual before operating your Woods equipment. The information presented will prepare you to do a better and safer job. Keep this manual handy for ready reference. Require all operators to read this manual carefully and become acquainted with all adjustment and operating procedures before attempting to operate. Replacement manuals can be obtained from your dealer. To obtain complete warranty details, visit WoodsEquipment.com/warranty. You may also request a hard copy by calling 1-800-319-6637 or mail your request to: Woods Equipment Company, Attn: Warranty Dept. 2606 South Illinois Route 2, Oregon, IL 61061. To locate your nearest dealer, check the Dealer Locator at www.WoodsEquipment.com, or in the United States and Canada call 1-800-319-6637.

The equipment you have purchased has been carefully engineered and manufactured to provide dependable and satisfactory use. Like all mechanical products, it will require cleaning and upkeep. Lubricate the unit as specified. Observe all safety information in this manual and safety decals on the equipment.

For service, your authorized Woods dealer has trained mechanics, genuine Woods service parts, and the necessary tools and equipment to handle all your needs.

Use only genuine Woods service parts. Substitute parts will void the warranty and may not meet standards required for safe and satisfactory operation. Record the model number and serial number of your equipment in the spaces provided:

Model: _____ **Date of Purchase:** _____

Serial Number: (see Safety Decal section for location) _____

Provide this information to your dealer to obtain correct repair parts.

Throughout this manual, the term **NOTICE** is used to indicate that failure to observe can cause damage to equipment. The terms **CAUTION**, **WARNING**, and **DANGER** are used in conjunction with the Safety-Alert Symbol (a triangle with an exclamation mark) to indicate the degree of hazard for items of personal safety.



This is the safety alert symbol. It is used to alert you to potential physical injury hazards. Obey all safety messages that follow this symbol to avoid possible injury or death.



Indicates a hazardous situation that, if not avoided, will result in death or serious injury.



Indicates a hazardous situation that, if not avoided, could result in death or serious injury.



Indicates a hazardous situation that, if not avoided, could result in minor or moderate injury.

**IMPORTANT
or NOTICE**

Is used to address practices not related to physical injury.

NOTE

Indicates helpful information.

2 Introduction

MAN1405
(04/29/2026)

TABLE OF CONTENTS

INTRODUCTION	2
SPECIFICATIONS	4
GENERAL INFORMATION	4
SAFETY	5
MOWER SAFETY VIDEO	5
SAFETY RULES	7
INSTALLATION	7
TRAINING	7
PREPARATION	7
TRANSPORTATION	8
OPERATION	9
MAINTENANCE	10
STORAGE	11
SAFETY & INSTRUCTIONAL DECALS	12
OPERATION	15
OPERATION	15
CONNECTING CUTTER TO TRACTOR	15
TRACTOR OPERATION	17
CUTTER OPERATION	17
TRANSPORTING	18
STORAGE	19
PRE-OPERATION CHECKLIST	20
OWNER SERVICE	21
OWNER SERVICE	21
BLOCKING METHOD	21
LUBRICATION	23
BLADES	23
SLIP CLUTCH ADJUSTMENT	24
SHIELDING REPAIR	25
SERVICING TIRES SAFELY	26
CLEANING	26
TROUBLESHOOTING	27
DEALER SERVICE	28
DEALER SERVICE	28
GEARBOX MAINTENANCE	28
GEARBOX REPAIR	29
SEAL REPAIR	29
SPLITTER GEARBOX REPAIR	31
CROSSBAR REMOVAL	33
CROSSBAR INSTALLATION	33
UNIVERSAL JOINT REPAIR	34
SERVICING TIRES SAFELY	35
ASSEMBLY	36
DEALER SET-UP INSTRUCTIONS	36
DEALER CHECKLISTS	38
PARTS INDEX	39
APPENDIX	57
BOLT TORQUE CHART	57
BOLT SIZE CHART & ABBREVIATIONS	58
INDEX	59



¡LEA EL INSTRUCTIVO!
Si no lee Ingles, pida ayuda a alguien que si lo lee para que le traduzca las medidas de seguridad.

NOTICE:
If you would like to receive a free Spanish language translation of the Safety Rules section of this manual, plus a set of Spanish language safety decals, please contact your local Woods dealer.

AVISO:
Si desea recibir una traducción al español gratuita de la sección de Reglas de seguridad de este manual y un juego de etiquetas de seguridad en español, por favor comuníquese con su concesionario local de Woods.



This Operator's Manual should be regarded as part of the machine. Suppliers of both new and second-hand machines must make sure that this manual is provided with the machine.

SPECIFICATIONS

BW10.30	
Cut Capacity	1.5"
Cutting Height (varies with tire selection)	2" - 12"
Cutting Width	120" (10' 0")
Overall Width	128" (10' 8")
Transport Width	82.13" (6' 11")
Overall Length (from drawbar pin with largest tires)	13' 7"
Tractor Maximum PTO HP	60
Tractor Minimum PTO HP	25
Tractor PTO RPM	540
Number of Blade Spindles	3
Blade Overlap (with wings level)	6"
Number of Blades (standard/optional)	6
Blade Rotation (viewed from above)	Left Spindle - CW, Center & Right Spindles - CCW
Blade Tip Speed - 540 RPM (wing/center) - FT/Min	15,800 / 13,100
Wing Driveline Category	Cat 3
CV Input Driveline Category	Cat 4
Deck Thickness	11 ga (.120)
Side Frame Thickness	7 ga (.180)
Weight (varies with tires & options) - LB	2175 - 2350
Tongue Weight (varies with options) - LB	745
Wheel/Tire Size Options	21" OD Laminated (70 LB) 21" Severe Duty (48 LB w/ air or 90 LB w/ foam) 21" Used Aircraft (34 LB w/ air)
Number of Wheels (min - max)	4
Driveline Torque Protection	Slip Clutch
Slip Clutch Type	2 Plate
Ambient Operating Temperature Range	-10° F to 110° F

GENERAL INFORMATION

WARNING

- Some illustrations in this manual show the mower with safety shields removed to provide a better view. The mower shall never be operated with any safety shielding removed.

The purpose of this manual is to assist you in operating and maintaining your cutter. Read it carefully. It furnishes information and instructions that will help you achieve years of dependable performance. These instructions have been compiled from extensive field experience and engineering data. Some information may be general in nature due to unknown and varying operating conditions. However, through experience

and these instructions, you should be able to develop procedures suitable to your particular situation.

The illustrations and data used in this manual were current at the time of printing but, due to possible inline production changes, your machine may vary slightly in detail. We reserve the right to redesign and change the machines as may be necessary without notification.

Throughout this manual, references are made to right and left directions. These are determined by standing behind the equipment facing the direction of forward travel. Blade rotation is clockwise (left wing) and counterclockwise (right wing and center section) as viewed from the top of the cutter.

4 Introduction

MAN1405
(04/29/2026)

BE SAFE!

BE ALERT!

BE ALIVE!

BE TRAINED

Before Operating Mowers!



*Safety Training
Does Make a Difference.*

Watch a Mower Safety Video Online

The AEM (Association of Equipment Manufacturers) offers a safety training video, *Industrial and Agricultural Mower Safety Practices*. The 22-minute video can be viewed online for free at TheAEMStore,

<https://youtu.be/EuktqJNAjhc>

It reinforces the proper procedures to follow while operating your mowing equipment. The video does not replace the information contained in the Operator's Manual, so please review this manual thoroughly before operating your new mowing equipment.

Also, available from the Association of Equipment Manufacturers:

A large variety of training materials (ideal for groups) are available for a nominal charge from AEM. Following is a partial list:

- **Training Package for Rotary Mowers/Cutters-English**
Contains: DVD & VHS (English)
 - Guidebook for Rotary Mowers/Cutters (English)
 - AEM Industrial/Agricultural Mower Safety Manual (English)
 - AEM Agricultural Tractor Safety Manual (English)
- **Training Package for Rotary Mowers/Cutters-English/Spanish**
Contains: DVD & VHS (English/Spanish)
 - Guidebook for Rotary Mowers/Cutters (English/Spanish)
 - AEM Industrial/Agricultural Mower Safety Manual (English/Spanish)
 - AEM Agricultural Tractor Safety Manual (English/Spanish)

AEM training packages are available through:

AEM at: www.shop.aem.org/en/promo/

or

Universal Lithographers, Inc. Email:

aem@ulilitho.com 800-369-2310 tel

866-541-1668 fax

SAFETY RULES



ATTENTION! BECOME ALERT! YOUR SAFETY IS INVOLVED!



Safety is a primary concern in the design and manufacture of our products. Unfortunately, our efforts to provide safe equipment can be wiped out by an operator's single careless act.

In addition to the design and configuration of equipment, hazard control and accident prevention are dependent upon the awareness, concern, judgement, and proper training of personnel involved in the operation, transport, maintenance, and storage of equipment.

It has been said, "The best safety device is an informed, careful operator." We ask you to be that kind of operator.

INSTALLATION

- Hydraulics must be connected as instructed in this manual. Do not substitute parts, modify, or connect in any other way. Refer to Dealer Set-up Instructions on page 36.

TRAINING

- This machine is capable of amputating hands and feet and throwing objects. Failure to observe the following safety instructions could result in serious injury or death.
- Safety instructions are important! Read all attachment and power unit manuals; follow all safety rules and safety decal information. (Replacement manuals and safety decals are available from your dealer. To locate your nearest dealer, check the Dealer Locator at www.WoodsEquipment.com, or in the United States and Canada call 1-800-319-6637.) Failure to follow instructions or safety rules can result in serious injury or death.
- If you do not understand any part of this manual and need assistance, see your dealer.
- Know your controls and how to stop engine and attachment quickly in an emergency.
- Operators must be instructed in and be capable of the safe operation of the equipment, its attachments, and all controls. Do not allow anyone to operate this equipment without proper instructions.
- Keep hands and body away from pressurized lines. Use paper or cardboard, not hands or other body parts to check for leaks. Wear safety goggles. Hydraulic fluid under pressure can easily penetrate skin and will cause serious injury or death.

- Make sure that all operating and service personnel know that if hydraulic fluid penetrates skin, it must be surgically removed as soon as possible by a doctor familiar with this form of injury or gangrene, serious injury, or death will result.

CONTACT A PHYSICIAN IMMEDIATELY IF FLUID ENTERS SKIN OR EYES. DO NOT DELAY.

- Never allow children or untrained persons to operate equipment.

PREPARATION

- Check that all hardware is properly installed. Always tighten to torque chart specifications unless instructed otherwise in this manual.
- Air in hydraulic systems can cause erratic operation and allows loads or equipment components to drop unexpectedly. When connecting equipment or hoses or performing any hydraulic maintenance, purge any air in hydraulic system by operating all hydraulic functions several times. Do this before putting into service or allowing anyone to approach the equipment.
- Route hydraulic hoses carefully to prevent damage. Hoses must not be twisted, bent sharply, kinked, frayed, pinched, or come into contact with any moving parts. Operate moveable components through full operational range to check clearances. Replace any damaged hose immediately.
- Set tractor hydraulic relief valve at 2500 psi (170 bars) (17,000 kPa) to prevent injury and equipment damage due to hydraulic system failure.
- Make sure all hydraulic hoses, fittings, and valves are in good condition and not leaking before starting power unit or using equipment. Check and route hoses carefully to prevent damage. Hoses must not be twisted, bent sharply, kinked, frayed, pinched, or come into contact with any moving parts. Operate moveable components through full operational range to check clearances. Replace any damaged hoses immediately.
- After connecting hoses, check that all control lever positions function as instructed in the Operator's Manual. Do not put into service until control lever and equipment movements are correct.
- Your dealer can supply original equipment hydraulic accessories and repair parts. Substitute parts may not meet original equipment specifications and may be dangerous.

(Safety Rules continued on next page)

MAN1405
(04/29/2026)

Safety 7

SAFETY RULES



ATTENTION! BECOME ALERT! YOUR SAFETY IS INVOLVED!



(Safety Rules continued from previous page)

- Always wear relatively tight and belted clothing to avoid getting caught in moving parts. Wear safety glasses or goggles, sturdy, rough-soled work shoes, gloves, and hearing protection. Respiratory protection may be required, depending on the work.
- When attaching a pull-type unit to the tractor drawbar, always use a high-strength drawbar pin that meets the requirements of the latest version of ANSI/ASABE S625. The drawbar pin must have a device that will lock it into position. Secure safety chain to attachment and tractor.
- Do not leave a running machine unattended. Always park on level ground, disengage tractor PTO, set parking brake, and stop engine.
- Make sure attachment is properly secured, adjusted, and in good operating condition.
- Make sure spring-activated locking pin or collar slides freely and is seated firmly in tractor PTO spline groove.
- If installed, make sure driveline guard tether chains are attached to the tractor and equipment as shown in the pamphlet that accompanies the driveline. Replace if damaged or broken. Check that driveline guards rotate freely on driveline before putting equipment into service.
- Before starting power unit, check all equipment driveline guards for damage. Replace any damaged guards. Make sure all guards rotate freely on all drivelines. If guards do not rotate freely on drive-lines, repair and replace bearings before putting equipment into service.
- Remove buildup of grease, oil, and debris from this equipment, power unit, and engine to avoid fire hazard.
- Make sure all safety decals are installed. Replace if damaged. (See Safety Decals section for location.)
- Make sure shields and guards are properly installed and in good condition. Replace if damaged.
- Do not put this equipment into service unless all side skids are properly installed and in good condition. Replace if damaged.
- Check that the tongue weight of the rotary cutter does not exceed the tractor's drawbar capacity. (Refer to specifications for machine's tongue weight.)

- A minimum 20% of tractor and equipment weight must be on the tractor front wheels when attachments are in transport position. Without this weight, front tractor wheels could raise up resulting in loss of steering. The weight may be attained with front wheel weights, ballast in tires, front tractor weights or front loader. Weigh the tractor and equipment. Do not estimate.
- Inspect and clear area of stones, branches, or other hard objects that might be thrown, causing injury or damage.
- Connect PTO driveline directly to power unit PTO shaft. Never use adapter sleeves or adapter shafts. Adapters can cause driveline failures due to incorrect spline or incorrect operating length and can result in personal injury or death.
- Equip tractor with a fire extinguisher and first aid kit.
- Always walk around tractors and machinery instead of stepping over or on the PTO shaft, PTO master shield, Power Input Connection or guards.

TRANSPORTATION

- Power unit must be equipped with Roll Over Protection System (ROPS) or ROPS cab and seat belt. Keep seat belt securely fastened. Falling off power unit can result in death from being run over or crushed. Keep foldable ROPS system in "locked up" position at all times.
- Always raise unit and install transport locks before transporting. Leak down or failure of mechanical or hydraulic system can cause equipment to drop.
- Always attach safety chain to tractor drawbar when transporting unit.
- Always comply with all state and local lighting and marking requirements. Check that all lights are working and turn on flashing warning lights before traveling on a public roadway.
- Check SMV sign and reflector condition before proceeding onto public roads.
- Never allow riders on power unit or attachment.
- Do not operate PTO during transport.
- Do not operate or transport on steep slopes. Refer to tractor manual for proper ballasting and slope recommendations.

(Safety Rules continued on next page)

SAFETY RULES



ATTENTION! BECOME ALERT! YOUR SAFETY IS INVOLVED!



(Safety Rules continued from previous page)

- When transporting, do not exceed 20 mph (30 kph) and use a towing vehicle whose weight is at least 2/3 the weight of the rotary cutter. (Refer to specifications for machine weights.)
- Do not operate or transport equipment while under the influence of alcohol or drugs.
- The maximum transport speed for this machine is 20 mph (30 km/h). Regardless of the maximum speed capability of the towing tractor, do not exceed the implement's maximum transport speed. Doing so could result in:
 - Loss of control of the implement and tractor
 - Reduced or no ability to stop during braking
 - Implement tire failure
 - Damage to the implement or its components.
- Use additional caution and reduce speed when under adverse surface conditions, turning, or on inclines.
- Never tow this implement with a motor vehicle.

OPERATION

- To avoid injury from thrown objects, do not allow bystanders or animals within 300 feet (92 m) of the area when operating the equipment.
- Do not allow bystanders or animals within 25 feet (7.6 m) when attaching, removing, assembling, or servicing equipment.
- Never walk, stand, or place yourself or others under a raised wing or in the path of a lowering wing. Hydraulic system leak-down, hydraulic system failures, mechanical failures, or movement of control levers can cause wings to drop unexpectedly and cause severe injury or death.
- Full chain shielding must be installed at all times. Thrown objects could injure people or animals or damage property.
 - If the machine is not equipped with full chain shielding, operation must be stopped.
 - This shielding is designed to reduce the risk of thrown objects. The mower deck and protective devices cannot prevent all objects from escaping the blade enclosure in every mowing condition. It is possible for objects to ricochet and escape, traveling as much as 300 feet (92m).
- Never direct discharge toward people, animals, or property.

- Disengage the tractor's PTO to stop blade rotation before crossing gravel surfaces.
- Do not operate or transport equipment while under the influence of alcohol or drugs.
- Operate only in daylight or good artificial light.
- Keep hands, feet, hair, and clothing away from equipment while engine is running. Stay clear of all moving parts.
- Always comply with all state and local lighting and marking requirements. Check that all lights are working and turn on flashing warning lights before traveling on a public roadway.
- Never allow riders on power unit or attachment.
- Tragic accidents can occur if the operator is not alert to the presence of children. Children are often attracted to the machine and the mowing activity. Never assume that children will remain where you last saw them.
- Keep children out of the operating area and under the watchful care of a responsible adult other than the operator.
- Do not carry children, even with the blade(s) shut off. Children could fall off and be seriously injured or interfere with safe machine operation. Children who have been given rides in the past could suddenly appear in the mowing area for another ride and be run over or backed over by the machine.
- Power unit must be equipped with ROPS or ROPS cab and seat belt. Keep seat belt securely fastened. Falling off power unit can result in death from being run over or crushed. Keep foldable ROPS system in "locked up" position at all times.
- Always sit in power unit seat when operating controls or starting engine. Securely fasten seat belt, place transmission in neutral, engage brake, and ensure all other controls are disengaged before starting power unit engine.
- Operate tractor PTO at 540 RPM. Do not exceed.
- Except in emergencies, reduce tractor engine speed to low idle before disengaging tractor PTO to prevent blades from sticking together.

(Safety Rules continued on next page)

SAFETY RULES



ATTENTION! BECOME ALERT! YOUR SAFETY IS INVOLVED!



(Safety Rules continued from previous page)

- Raise or lower wings slowly to prevent personal injury or damage to cutter.
- Look down and to the rear and make sure area is clear before operating in reverse.
- Do not operate or transport on steep slopes. Refer to tractor manual for proper ballasting and slope recommendations.
- Do not stop, start, or change directions suddenly on slopes.
- Watch for hidden hazards on the terrain during operation.
- Stop power unit and equipment immediately upon striking an obstruction. Turn off engine, set parking brake, remove key, inspect, and repair any damage before resuming operation.
- Always walk around tractors and machinery instead of stepping over or on the PTO driveline shafts or tongue.
- Do not operate at ambient temperatures above 110°F. Gearboxes may become too hot to safely touch.
- Continuous operation while the clutch is slipping could cause heat build-up resulting in fire. Adjust slip clutch pressure by tightening springs to the dimension shown in the "Owner Service" section. If clutch is set to minimum spring length, replace the friction disks as shown.

MAINTENANCE

- Before dismounting tractor or performing any service or maintenance, follow these steps:
 - Disengage power to equipment and wait for all moving parts to stop.
 - Lower all raised components to the ground and operate valve levers to release any hydraulic pressure.
 - Place all controls in neutral and set parking brake.
 - Stop tractor engine, remove ignition key and unfasten seat belt.
- Do not modify or alter or permit anyone else to modify or alter the equipment or any of its components in any way.
- Your dealer can supply original equipment hydraulic accessories and repair parts. Substitute parts may not meet original equipment specifications and may be dangerous.
- To prevent contamination during maintenance and storage, clean and then cover hose ends, fittings, and hydraulic ports with tape.
- To avoid injury from thrown objects, do not allow bystanders or animals within 300 feet (92 m) of the area when operating the equipment.
- Do not allow bystanders or animals within 25 feet (7.6 m) when attaching, removing, assembling, or servicing equipment.
- Wear long sleeves, long pants, boots, and gloves when cleaning machine to avoid contact with poisonous plants.
- Inspect suspension components and relieve spring pressure before disassembling any springs.
- Use care when installing or removing suspension springs. Springs store energy when compressed and, if released suddenly, can cause personal injury.
- Always make sure any material and waste products from the repair and maintenance of the implement are properly collected and disposed.
- Never go underneath equipment (lowered to the ground or raised) unless it is properly blocked and secured. Never place any part of the body underneath equipment or between moveable parts even when the engine has been turned off. Hydraulic system leak down, hydraulic system failures, mechanical failures, or movement of control levers can cause equipment to drop or rotate unexpectedly and cause severe injury or death. Follow Operator's Manual instructions for working underneath and blocking requirements or have work done by an authorized dealer.
- Keep all persons away from operator control area while performing adjustments, service, or maintenance.
- Make certain all movement of equipment components has stopped before approaching for service.
- Frequently check blades. They should be sharp, free of nicks and cracks, and securely fastened.
- Do not handle blades with bare hands. Wear gloves. Careless or improper handling may result in injury.

(Safety Rules continued on next page)

SAFETY RULES



ATTENTION! BECOME ALERT! YOUR SAFETY IS INVOLVED!



(Safety Rules continued from previous page)

- Your dealer can supply genuine replacement blades. Substitute blades may not meet original equipment specifications and may be dangerous.
- Tighten all bolts, nuts, and screws to torque chart specifications. Check that all cotter pins are installed securely to ensure equipment is in a safe condition before putting unit into service.
- Make sure all safety decals are installed. Replace if damaged. (See Safety Decals section for location.)
- Make sure shields and guards are properly installed and in good condition. Replace if damaged.
- Never perform cleaning, service or maintenance with engine running.
- Do not disconnect hydraulic lines until engine is stopped, power unit is properly secured, equipment and all components are lowered to the ground, and system pressure is released by operating all valve control levers.
- When lubricating telescoping PTO drives, keep fingers out of shield access slots to prevent injury.
- Service and maintenance work not covered in OWNER SERVICE must be done by a qualified dealership. Special skills, tools, and safety procedures may be required. Failure to follow these instructions can result in serious injury or death.
- Explosive separation of tire and rim parts can cause serious injury or death. Release all air pressure before loosening bolts on wheel.

STORAGE

- Before disconnecting and storing, follow these instructions:
 - Store on level, solid ground.
 - Disengage power to equipment and wait for all moving parts to stop.
 - Lower wings to ground.
 - Raise cutter center section and pin transport bar in raised position.
 - Disconnect input driveline from tractor and use the *SmartLift™* CV lift assist to store off the ground.
 - Place wedge blocks at front and rear of wheels on center section and each wing to prevent wheel rotation.
 - Attach parking jack and raise tongue weight off tractor drawbar.
 - Securely block all four corners of center section and each wing with jackstands.
 - Remove hydraulic hoses after tractor is turned off and all system pressure is released by operating valve levers several times.
 - Remove safety tow chain.
 - Remove retainer pin and high strength drawbar pin.
- Keep children, bystanders, and animals away from the equipment and the storage area.

SAFETY & INSTRUCTIONAL DECALS



ATTENTION! BECOME ALERT! YOUR SAFETY IS INVOLVED!



Replace Immediately If Damaged!

Serial Number Tag - 1033176

* **NOTE:** For surfaces painted with a textured paint, add "MB" to the part number when ordering replacement safety decals. Example: 15502MB

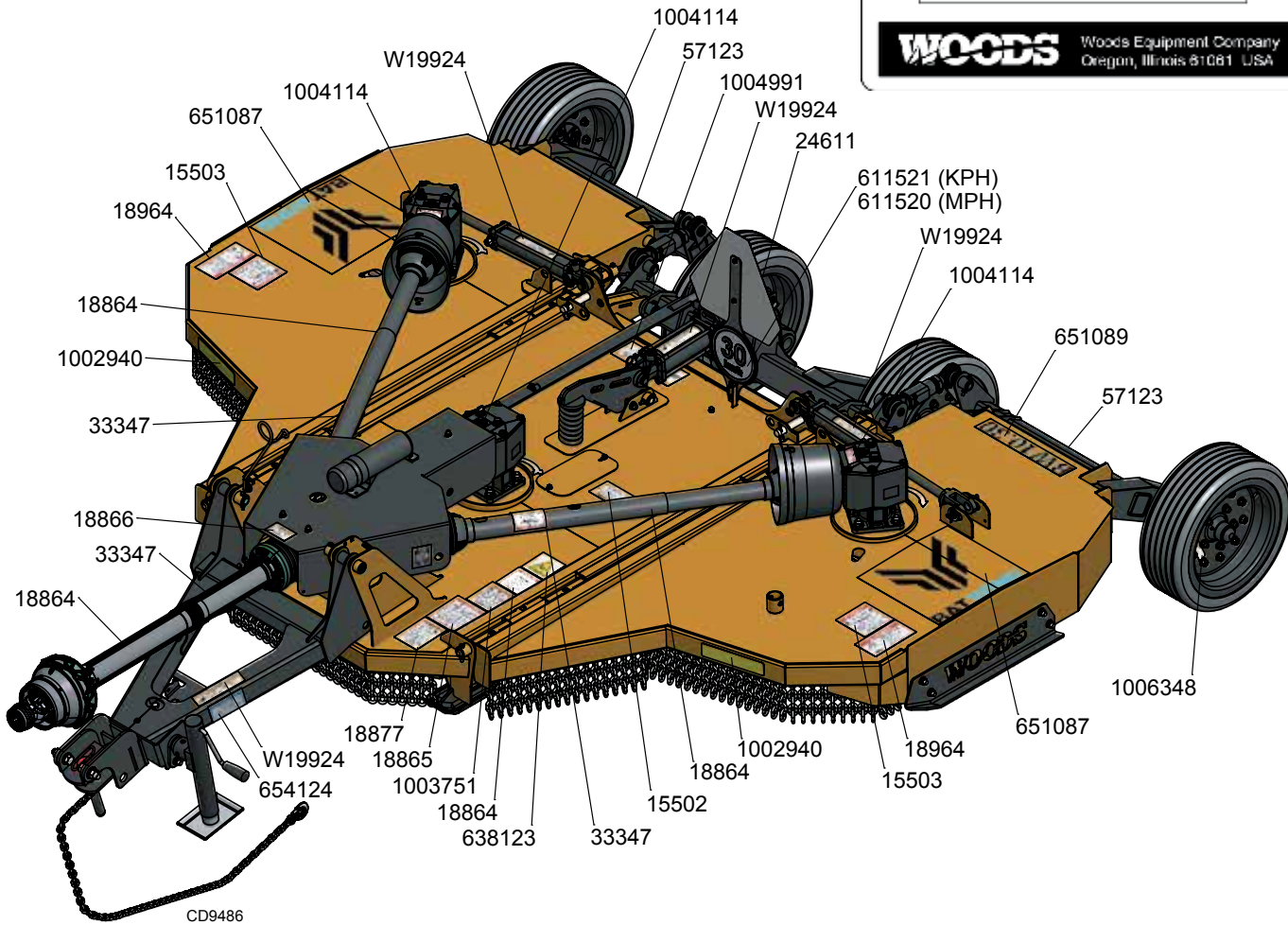

4 - PN 1006348 - Located on Wheel Rims

BE CAREFUL!

WARNING	EXPLOSION HAZARD
	RELEASE ALL AIR PRESSURE BEFORE LOOSENING BOLTS. FAILURE TO DO SO COULD RESULT IN SERIOUS INJURY OR DEATH. MAX. SPEED: 20 MPH, MAX. WEIGHT: 4000 LBS., MAX. AIR PRESSURE: 40 PSI.

Use a clean, damp cloth to clean safety decals.

Avoid spraying too close to decals or serial tag when using a pressure washer; high-pressure water can enter through very small scratches or under edges of decals causing them to peel or come off.

PN 1002940 FRONT AMBER REFLECTOR

PN 57123 REAR RED REFLECTOR

Replacement safety decals can be ordered free from your Woods dealer. To locate your nearest dealer, check the Dealer Locator at www.WoodsEquipment.com, or in the United States and Canada call 1-800-319-6637.

SAFETY & INSTRUCTIONAL DECALS



ATTENTION! BECOME ALERT! YOUR SAFETY IS INVOLVED!



Replace Immediately If Damaged!

* **NOTE:** For surfaces painted with a textured paint, add "MB" to the part number when ordering replacement safety decals. Example: 15502MB

PN 18866, 18866MB* (540 RPM)



PN 638123, 638123MB* - Slippery Surface



PN 15503, 15503MB*



PN W19924, W19924MB*



PN 18864, 18864MB*



PN 1004114, 1004114MB*



PN 654124

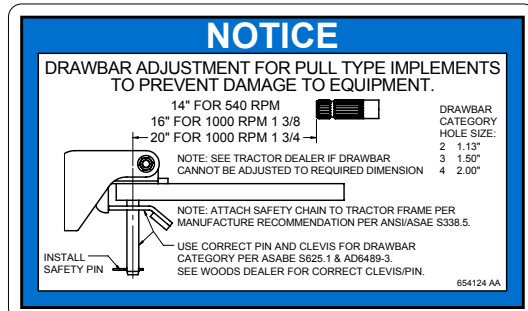

PN 18865, 18865MB*



SAFETY & INSTRUCTIONAL DECALS



ATTENTION! BECOME ALERT! YOUR SAFETY IS INVOLVED!



Replace Immediately If Damaged!

* **NOTE:** For surfaces painted with a textured paint, add "MB" to the part number when ordering replacement safety decals. Example: 15502MB

PN 1004991, 1004991MB*

⚠ WARNING		
	<p>RAISED IMPLEMENT CAN DROP AND CRUSH</p> <ul style="list-style-type: none"> Implement must be equipped with transport lock. Before working underneath, transport lock must be in the raised position. All corners of implement must be securely blocked with jackstands. All transport components must be functional, kept in good condition, and stored on equipment. Blocking up prevents implement dropping from hydraulic leak down, hydraulic system failures, or mechanical component failures. <p>FAILURE TO FOLLOW INSTRUCTIONS CAN RESULT IN SERIOUS INJURY OR DEATH.</p>	<p>TRANSPORT LOCK AND CYLINDER REQUIREMENTS</p> <p>SINGLE-ACTING FULL EXTENSION</p> <p>TRANSPORT LOCK</p>
	<p>1004991 AC</p>	

PN 33347

<p>⚠ DANGER</p> <p>GUARD MISSING. DO NOT OPERATE.</p>
<p>⚠ DANGER</p> <p>GUARD MISSING. DO NOT OPERATE.</p> <p>33347 AG</p>
<p>⚠ DANGER</p>

PN 1003751, 1003751MB*

⚠ WARNING
<p>CRUSHING AND PINCHING HAZARD</p> <ul style="list-style-type: none"> Be extremely careful handling various parts of the machine. They are heavy and hands, fingers, feet, and other body parts could be crushed or pinched between tractor and implement. Operate tractor controls from tractor seat only. Do not stand between tractor and implement when tractor is in gear. Make sure parking brake is engaged before going between tractor and implement. Stand clear of machine while in operation or when it is being raised or lowered. <p>FAILURE TO FOLLOW THESE INSTRUCTIONS COULD RESULT IN SERIOUS INJURY OR DEATH.</p> <p>1003751 AE</p>

PN 18877, 18877MB*

⚠ WARNING
<p>TO AVOID SERIOUS INJURY OR DEATH:</p> <ul style="list-style-type: none"> Read Operator's Manual (available from dealer) and follow all safety precautions. Keep all shields in place and in good condition. Operate mower from tractor seat only. Lower mower, stop engine and remove key before dismounting tractor. Allow no children or untrained persons to operate equipment. Do not transport towed or semi-mounted units over 20 mph (30 km/h). <p>FAILURE TO OPERATE SAFELY CAN RESULT IN INJURY OR DEATH.</p> <p>18877 AI</p>

PN 15502, 15502MB*

⚠ WARNING
<p>ROTATING COMPONENTS</p> <p>Do not operate without cover in place. Look and listen for rotation. Do not open cover until all components have stopped.</p> <p>CONTACT WITH ROTATING PARTS CAN CAUSE SERIOUS INJURY.</p> <p>15502 AD</p>

PN 18964, 18964MB*

⚠ DANGER	
	<p>RAISED WING EXPOSES BLADE AND INCREASES THROWN OBJECT HAZARDS.</p> <ul style="list-style-type: none"> Only raise for transport. Stop cutter and lock wing(s) up. <p>RAISED WING CAN FALL AND CRUSH.</p> <ul style="list-style-type: none"> Keep away. Lock up with wing transport bars. Lower wing(s) after transport and for storage. <p>FAILURE TO FOLLOW INSTRUCTIONS CAN RESULT IN SERIOUS INJURY OR DEATH.</p> <p>18964 AD</p>

PN 611520



PN 611521



OPERATION

The designed and tested safety of this machine depends on it being operated within the limitations as explained in this manual. Be familiar with and follow all safety rules in the manual, on the cutter and on the tractor.

This Batwing® rotary cutter is intended to mow or shred grass, weeds, brush, and crop residue when attached to a tractor. Refer to SPECIFICATIONS for recommended tractor PTO hp by model.

The safe operation of this cutter is the responsibility of the operator, who must be properly trained. The operator should be familiar with the equipment and all safety practices before starting operation. Read the safety information on page 7 through page 14.

Recommended tractor ground speed for most conditions is from 1 to 6 mph.

Always operate tractor at 540 RPM PTO speed when using your machine.

! DANGER

- Full chain shielding must be installed at all times. Thrown objects could injure people or animals or damage property.
 - If the machine is not equipped with full chain shielding, operation must be stopped.
 - This shielding is designed to reduce the risk of thrown objects. The mower deck and protective devices cannot prevent all objects from escaping the blade enclosure in every mowing condition. It is possible for objects to ricochet and escape, traveling as much as 300 feet (92m).

! WARNING

- Never allow children or untrained persons to operate equipment.
- To avoid injury from thrown objects, do not allow bystanders or animals within 300 feet (92 m) of the area when operating the equipment.
- Do not allow bystanders or animals within 25 feet (7.6 m) when attaching, removing, assembling, or servicing equipment.
- Make sure spring-activated locking pin or collar slides freely and is seated firmly in tractor PTO spline groove.
- Make sure that tractor PTO Master Shield is in place and has a 2" overlap with driveline shield.

! CAUTION

- Stop power unit and equipment immediately upon striking an obstruction. Turn off engine, remove key, inspect, and repair any damage before resuming operation.
- Always wear relatively tight and belted clothing to avoid entanglement in moving parts. Wear safety glasses or goggles, sturdy, rough-soled work shoes, gloves, and hearing protection. Respiratory protection may be required, depending on the work.

CONNECTING CUTTER TO TRACTOR

NOTICE

- For tractors with a 1-3/8" diameter PTO shaft, the horizontal distance from the end of the tractor PTO shaft to the center of drawbar pin should be 14" for 540 RPM cutter. This will minimize joint knock and damage to drive components.

Leveling Tongue Clevis

The Batwing cutter has a system to help hold the clevis level while backing up to the cutter. Follow the instruction below.

1. Install hitch pin as shown to hold tongue level in desired position.
2. Note several leveling locations depending on tractor drawbar height.
3. Pull hitch pin and install in drawbar as normal once tractor is in place.

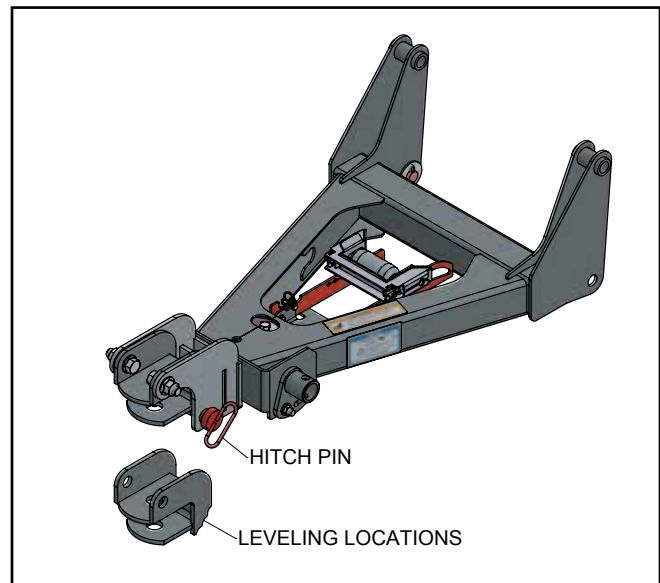

Figure 1. Leveling Tongue Clevis

Use of the *SmartLift*[™] CV Lift Assist System (Optional)

The Batwing[®] cutter has a system to help lift and support the driveline while connecting and disconnecting it from the tractor. Follow the instructions below.

1. Remove klik pin.
2. Lift lever to vertical position which will lift driveline.
3. Connect coupler to tractor PTO shaft.
4. Lower lever and secure with klik pin.

If the driveline is held too high or low, the roller carriage can be adjusted by removing the mounting bolts, moving it to the preferred position, and replacing the bolts.

NOTICE

Do not operate with the *SmartLift*[™] CV lift in the raised position to prevent damage to drive-line and lift assist.



Figure 2. Cutter to Tractor Connection

Mechanical Connection (Figure 2)

1. Check the size of the tractor drawbar hole and use the 1-1/8" diameter Category 2 clevis pin and retain-er clip to secure.

NOTE: For tractor drawbars with a larger hole size, contact your dealer for a Category 3 or Category 4 clevis and matching clevis pin.

2. Attach safety tow chain to drawbar support. Leave enough slack for turning.
3. Connect cutter driveline to tractor PTO shaft, making sure the spring-activated lock pin slides freely and is seated in tractor PTO splined groove.
4. Attach driveline shield tether chain to tractor drawbar to prevent rotation, if provided.
5. With cutter supported by the tractor drawbar, remove the lower bolt in the jack mount and pivot the jack so the foot plate is flat on the ground. Reinsert bolt and tighten.

NOTE: It may be necessary to slightly loosen the pivot bolt at the center of the jack mount to allow it to pivot. Tighten bolt after adjustment.

6. Remove parking jack from the tongue and attach it to the storage post on the front of the left wing.

Hydraulic Connection

1. Inspect hydraulic cylinders, fittings and hoses to ensure they are in good condition. Repair or replace all damaged parts.
2. Clean the fittings before connecting them to the tractor hydraulic ports.
3. Adjust the hose and wire positions to suit the tractor by loosening clamps and allowing the excess to loop over the gearbox shield. Tighten clamps and make sure the hoses and wire do not contact the PTO shaft and do not become snagged when turning.
4. Attach the hydraulic hose to the tractor. Refer to tractor operator's manual for details.
5. From the operator position, start tractor and raise and lower deck several times to purge trapped air from the hydraulic cylinder.

NOTE: The Batwing[®] hydraulic system is only compatible with petroleum-based fluids.

Interference Check

1. Be sure that tractor 3-point lift links do not interfere with hydraulic hoses, cutter driveline, or cutter frame.
2. Check for straight-ahead operation and at full turning angles. If there is any interference, remove the lower lift links.
3. Contact between tractor lift links and cutter parts can cause damage, especially when turning.

CV Driveline Turning Limits

NOTICE

- You must not exceed a turning angle of 80 degrees at the head of the Constant Velocity driveline or damage will occur.

1. To check for potential excessive turn angle, disconnect the driveline from tractor.
2. Start engine and turn as far right or left as possible while driving forward.
3. Shut engine off and try to connect CV driveline to tractor. If it cannot be connected, the turn angle is too severe.
4. Restart engine and straighten angle slightly, shut off engine and try to connect CV driveline to tractor.
5. Repeat the process until the driveline can be connected. The point at which the driveline can be connected is the maximum turn that should be made.

Cutting Height Adjustment

NOTICE

- **Avoid ground contact with blades. Striking ground with blades produces one of the most damaging shock loads a cutter can encounter. If this occurs repeatedly, the cutter, driveline, and gearboxes will be damaged.**

Cutting height range is from 2" to 12". A hydraulic cylinder is used for cutting height adjustment.

Stroke control spacers are included to return to the same desired cutting height.

When selecting a cutting height, you should consider the area of operation. If the ground is rolling and has mounds the blades could contact, set the cutting height accordingly. The cutting height (blade edge) is approximately 1-3/4" above the bottom of the side skid.

Cutting Height (Normal Mowing) - Center Section

1. Position the cutter on a hard level surface and select an approximate cutting height, (example 6").
2. Raise wings and lock them in the UP position.
3. Raise or lower the center section to obtain a distance of 14-1/2" from the ground to the center of the rear wing hinge pin.
4. Measure the distance from the ground to the center of the front wing hinge pin. It should be about 14-0" for normal mowing.
5. If necessary, using 1.5" wrench loosen jam nuts on attitude rod which runs from the tongue to the rear wheel arm and adjust until the front of the hinge pin is about 1/2" lower than the rear. Loosening the nut will lower the front of the mower.

NOTE: For tractor with draw bar higher than 18" the spacer bushing between jam nuts can be removed.

6. Tighten both jam nuts.

NOTICE

- **You may operate the cutter with the deck 1/2" to 1" higher in the front than in the rear to increase shredding or mulching action, but it will require more power and fuel.**

Cutting Height (Normal Mowing) - Wings

1. Lower wings to normal mowing position.
2. Measure from the ground up to the center of the wing wheel arm pivot pin near the wing hinge and to the center of the wing wheel arm pivot pin near the outside of the wing.
3. To level, using a 1-7/8" wrench loosen the jam nut on the turn-buckle assembly. Use a 2" wrench to turn the large square nut. Lengthening the linkage will raise the outer end of the wing and shortening it will lower the wing.
4. When the wing wheel arm pins are the same distance from the ground, the wing will be level. Hold the large square nut and torque the jam nut to 150 lbs-ft.
5. Repeat procedure for the opposite wing.

TRACTOR OPERATION

Use care when operating around tree limbs and other low objects. Avoid being knocked off tractor and being injured.

⚠ WARNING

- **Power unit must be equipped with ROPS or ROPS cab and seat belt. Keep seat belt securely fastened. Falling off power unit can result in death from being run over or crushed. Keep foldable ROPS system in "locked up" position at all times. The cutter is operated with tractor controls. Engage the PTO at a low RPM to prevent excessive loads on the cutter drive system. Increase throttle to recommended PTO operating RPM.**

Be sure operator is familiar with all controls and can stop tractor and cutter quickly in an emergency. The operator should give complete, undivided attention to operating tractor and cutter.

CUTTER OPERATION

⚠ WARNING

- **To avoid injury from thrown objects, do not allow bystanders or animals within 300 feet (92 m) of the area when operating the equipment.**

Power for operating the cutter is supplied by the tractor PTO. Operate tractor PTO at 540 RPM. Do not exceed.

Know how to stop the tractor and cutter quickly in an emergency.

Engage PTO at a low engine, RPM to minimize stress on the drive system and gearbox.

With PTO engaged, raise PTO speed to 540 RPM and maintain throughout cutting operation.

Gearbox protection is provided by a slip clutch with replacement fiber disc. The slip clutch is designed to slip when excessive torsional loads occur.

Move slowly into material. Adjust tractor ground speed to provide a clean cut without lugging the tractor engine.

Use a slow ground speed for better shredding.

Proper ground speed will depend on the terrain and the material's height, type, and density.

Normally, ground speed will range from 1 to 6 mph. Tall, dense material should be cut at a low speed; thin, medium-height material can be cut at a faster ground speed.

Always operate tractor PTO at proper RPM (540) to maintain blade speed and to produce a clean cut.

Under certain conditions tractor tires may roll down some grass and prevent cutting at the same height as the surrounding area. When this occurs, reduce your

ground speed but maintain PTO at 540 RPM. The lower ground speed will permit grass to rebound partially.

Do not operate at ambient temperatures above 110°F. Gearboxes may become too hot to safely touch and shaft seals may be damaged.

Mowing Tips

WARNING

- Look down and to the rear and make sure area is clear before operating in reverse.
- Do not operate or transport on steep slopes.
- Do not stop, start, or change directions suddenly on slopes.
- Use additional caution and reduce speed when under adverse surface conditions, turning, or on inclines.
- Watch for hidden hazards on the terrain during operation.

CAUTION

- Stop power unit and equipment immediately upon striking an obstruction. Turn off engine, remove key, inspect, and repair any damage before resuming operation.

Maximum recommended ground speed for cutting or shredding is 6 miles per hour. Adjust tractor ground speed by using higher or lower gears to provide a clean cut without lugging tractor engine.

Tall material should be cut twice. Cut material higher the first pass. Cut at desired height at 90 degrees the second pass.

Remember, sharp blades produce cleaner cuts and use less power. Refer to Blade Sharpening, page 24.

Before entering an area, analyze it to determine the best procedure. Consider the height and type of material to be cut and the terrain type (hilly, level or rough, etc.).

Shredding

The cutter may be used to shred various crops including green manure, straw, stubble, asparagus residue, corn stalks and similar crops in preparation for tilling. It may also be used to shred pruning in orchards, groves and vineyards.

Each shredding operation may require a different set-up. Start with front edge of cutter high. Adjust up or down as necessary with attitude rod. Experiment until you obtain the results you want.

When adjusting attitude for shredding, also check that the wings are level and adjust as needed.

TRANSPORTING

WARNING

- Power unit must be equipped with Roll Over Protection System (ROPS) or ROPS cab and seat belt. Keep seat belt securely fastened. Falling off power unit can result in death from being run over or crushed. Keep foldable ROPS system in “locked up” position at all times.
- Always raise unit and install transport locks before transporting. Leak down or failure of mechanical or hydraulic system can cause equipment to drop.
- Check that all lights are working and turn on flashing warning lights before traveling on a public roadway.
- Always attach safety chain to tractor drawbar when transporting unit.
- Check SMV sign and reflector condition before proceeding onto public roads.
- When transporting, do not exceed 20 mph (30 kph) and use a towing vehicle whose weight is at least 2/3 the weight of the rotary cutter. (Refer to specifications for machine weights.)
- Never allow riders on power unit or attachment.
- Do not operate PTO during transport.
- Do not operate or transport on steep slopes. Refer to tractor manual for proper ballasting and slope recommendations.
- Do not operate or transport equipment while under the influence of alcohol or drugs.

CAUTION

- Always comply with all federal, state and local lighting and marking requirements. Check that all lights are working and turn on flashing warning lights before traveling on a public roadway.

Lock-Up

Always transport with wings and center frame in the raised, locked position.

Wing Lock-Up

1. Raise wing to the up position.
2. Remove klik pin and lock pin from storage position.
3. Place lock pin in lock position and secure with klik pin.
4. Repeat steps 1 to 3 for opposite wing.
5. Lower cylinder against lock-up pins (Figure 3).

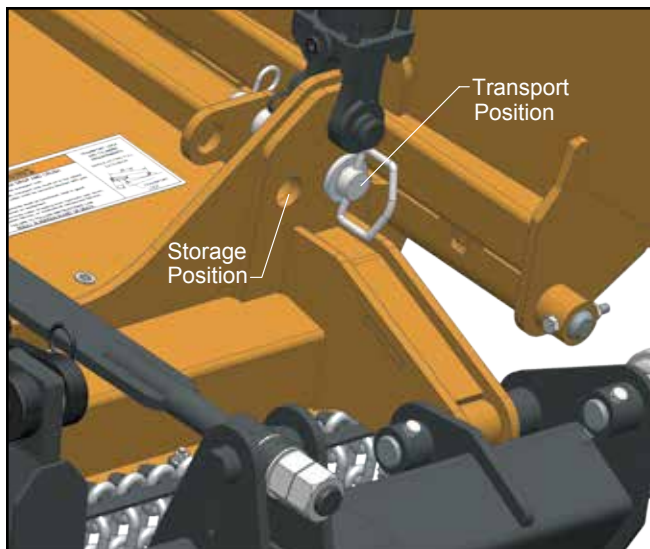

Figure 3. Transport Lock Pin

Center Section Lock-Up

1. Raise cutter with hydraulic cylinder to maximum height.
2. Flip the stop over the cut height bushings. (Figure 4)

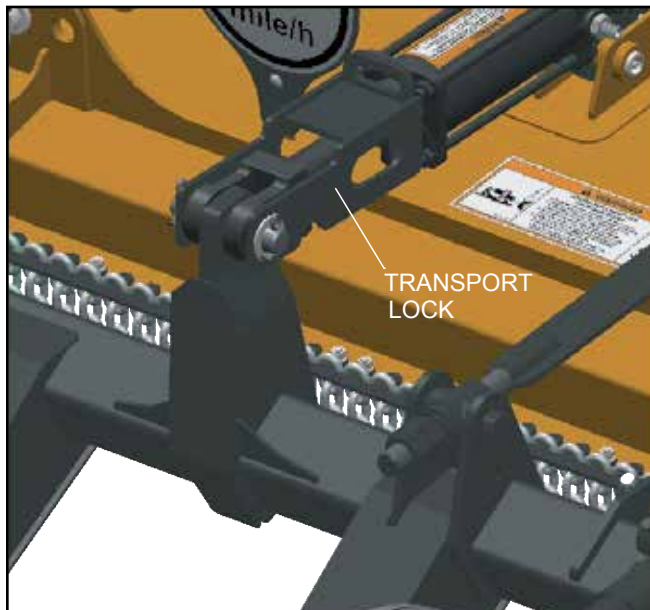

Figure 4. Transport Lock Position

3. To lower cutter for operation, extend the hydraulic cylinder to raise the cutter. Flip the stop back to storage position. (Figure 5).
4. Lower cutter to desired cutting height
5. Clip stroke control bushings on the lift cylinder rod to maintain cutting height during use.

NOTE: Use the various sizes of bushings to achieve the desired stack height. Extra bushings can be clipped on the rocker above the spring.

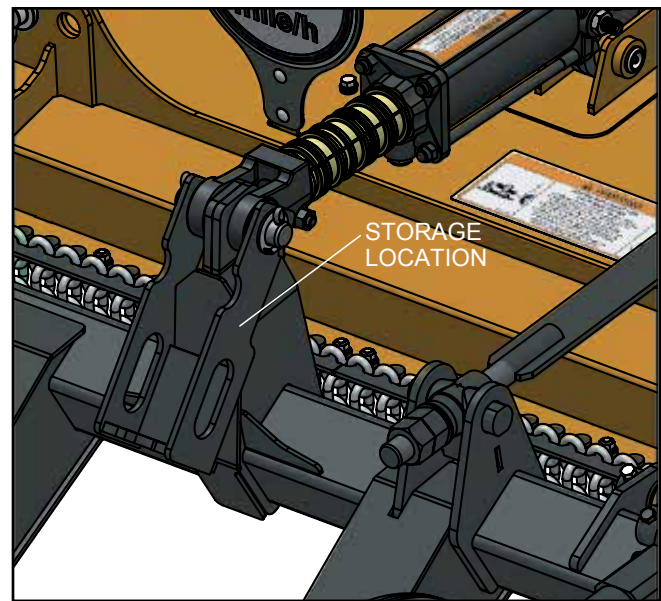

Figure 5. Transport Lock in Operation Position

STORAGE

Follow these steps when storing your cutter:

1. Clean cutter before storing. See page 26 for cleaning instructions. Store on level, solid ground.
2. Disconnect input driveline from tractor and use the *SmartLift™* CV lift assist to store off the ground.
3. Lower wings to ground.
4. Raise cutter center section and flip stop to hold in raised position.
5. Attach parking jack and raise tongue weight off tractor drawbar.
6. Place wedge blocks at front and rear of wheels on center section and each wing to prevent wheel rotation.
7. Securely block all four corners of center section and each wing with jack stands.
8. Remove hydraulic hoses after tractor is turned off and all system pressure is released by operating valve levers several times.
9. Remove safety tow chain.
10. Remove retainer pin and high strength drawbar pin.
11. Keep children, bystanders, and animals away from the equipment and the storage area.

PRE-OPERATION CHECKLIST

(OWNER'S RESPONSIBILITY)

- _____ Review and follow all safety rules and safety decal instructions on page 7 through page 14.
- _____ Check that all safety decals are installed and in good condition. Replace if damaged.
- _____ Check that equipment is properly and securely attached to tractor.
- _____ Make sure driveline spring-activated locking pin or collar slides freely and is seated firmly in tractor PTO spline groove.
- _____ Check all lubrication points and grease as instructed in lubrication information. Make sure the PTO slip joint is lubricated and that the gearbox fluid levels are correct.
- _____ Set tractor PTO at correct RPM for your equipment.
- _____ Lubricate all grease fitting locations. Make sure PTO shaft slip joint is lubricated.
- _____ Check that all hydraulic hoses and fittings are in good condition and not leaking before starting tractor. Check that hoses are not twisted, bent sharply, kinked, frayed, or pulled tight. Replace any damaged hoses immediately.
- _____ Check that all hardware is properly installed and secured.
- _____ Check cutting height and attitude adjustment.
- _____ Raise and lower equipment to make sure air is purged from hydraulic cylinders and hoses.
- _____ Check that blades are sharp and secure and cutting edge is positioned to lead in a counter clockwise rotation for center and right wings, and clockwise for left wing.
- _____ Inspect crossbar hub nuts are tight, with cotter pin inserted and spread. Make sure crossbar is not bent or cracked and replace if damaged.
- _____ Make sure tractor ROPS or ROPS cab and seat belt are in good condition. Keep seat belt securely fastened during operation.
- _____ Check that shields and guards are properly installed and in good condition. Replace if damaged.
- _____ Before starting engine, operator must be in tractor seat with seat belt fastened. Place transmission in neutral or park, engage brake and disengage tractor PTO.
- _____ Inspect area to be cut and remove stones, branches, or other hard objects that might be thrown and cause injury or damage.
- _____ Inspect rubber or chain shielding and replace any damaged rubber shield or missing links.
- _____ Make sure tractor 3-point lift links do not interfere with hydraulic hoses or driveline throughout full turning range.
- _____ Inspect tractor drawbar, clevis weldment, clevis pin, hitch weldment and hitch angle stop for signs of cracks or wear at the connecting point and the pivots. Make sure that all bolts are tight. Replace any damaged parts.

OWNER SERVICE

The information in this section is written for operators who possess basic mechanical skills. If you need help, your dealer has trained service technicians available. For your protection, read and follow the safety information in this manual.

WARNING

- Keep all persons away from operator control area while performing adjustments, service, or maintenance.
- Before performing any service or maintenance, follow these steps:
 - Disengage power to equipment and wait for all moving parts to stop.
 - Lower all raised components to the ground and operate valve levers to release any hydraulic pressure.
 - Place all controls in neutral and set parking brake.
 - Stop tractor engine, remove ignition key and unfasten seat belt.
- Before working underneath, disconnect driveline from tractor, lower wings to ground, raise cutter, and pin transport bar in raised position. Attach parking jack and lower to ground. Securely block all four corners of center section and each wing with jack stands. Blocking up prevents the cutter from dropping due to hydraulic leak down, hydraulic system failure, or mechanical component failure.
- Service and maintenance work not covered in OWNER SERVICE must be done by a qualified dealership. Special skills, tools, and safety procedures may be required. Failure to follow these instructions can result in serious injury or death.
- Before cleaning, servicing, adjusting, repairing or unplugging, stop tractor engine, place all controls in neutral, set park brake, remove ignition key, and wait for all moving parts to stop.
- Never perform cleaning, service or maintenance with engine running.

CAUTION

- If you do not understand any part of this manual and need assistance, see your dealer.
- Always wear relatively tight and belted clothing to avoid entanglement in moving parts. Wear safety glasses or goggles, sturdy, rough-soled work shoes, gloves, and hearing protection. Respiratory protection may be required, depending on the work.
- Wear long sleeves, long pants, boots, and gloves when cleaning machine to avoid contact with poisonous plants.

BLOCKING METHOD

To minimize the potential hazards of working underneath the cutter, follow these procedures:

WARNING

- Before performing any service or maintenance, lower equipment to ground or block securely, turn off engine, remove key, and disconnect driveline from tractor PTO.
- Never go underneath equipment (lowered to the ground or raised) unless it is properly blocked and secured. Never place any part of the body underneath equipment or between moveable parts even when the engine has been turned off. Hydraulic system leak down, hydraulic system failures, mechanical failures, or movement of control levers can cause equipment to drop or rotate unexpectedly and cause severe injury or death. Follow Operator's Manual instructions for working underneath and blocking requirements or have work done by a qualified dealer.

Do not position jackstands under wheels, axles, or wheel supports. Components can rotate and cause cutter to fall.

1. Jackstands with a load rating of 1000 lbs. or more are the only approved blocking device for this cutter. Install jackstands (shown by Xs in Figure 6) under the cutter before working underneath unit.
2. Consider the overall stability of the blocked unit. Just placing jackstands underneath will not ensure your safety.

The working surface must be level and solid to support the weight on the jackstands. Make sure jackstands are stable, both top and bottom. Make sure cutter is approximately level.
3. With full cutter weight lowered onto jackstands, test blocking stability before working underneath.
4. If cutter is attached to tractor when blocking, set the brakes, remove key, and block cutter before working underneath.
5. Securely block rear tractor wheels, in front and behind.

NOTICE

- If the cutter moves during storage and pressurizes the hoses, that pressure can be relieved by jacking at the locations shown by X's in Figure 6.

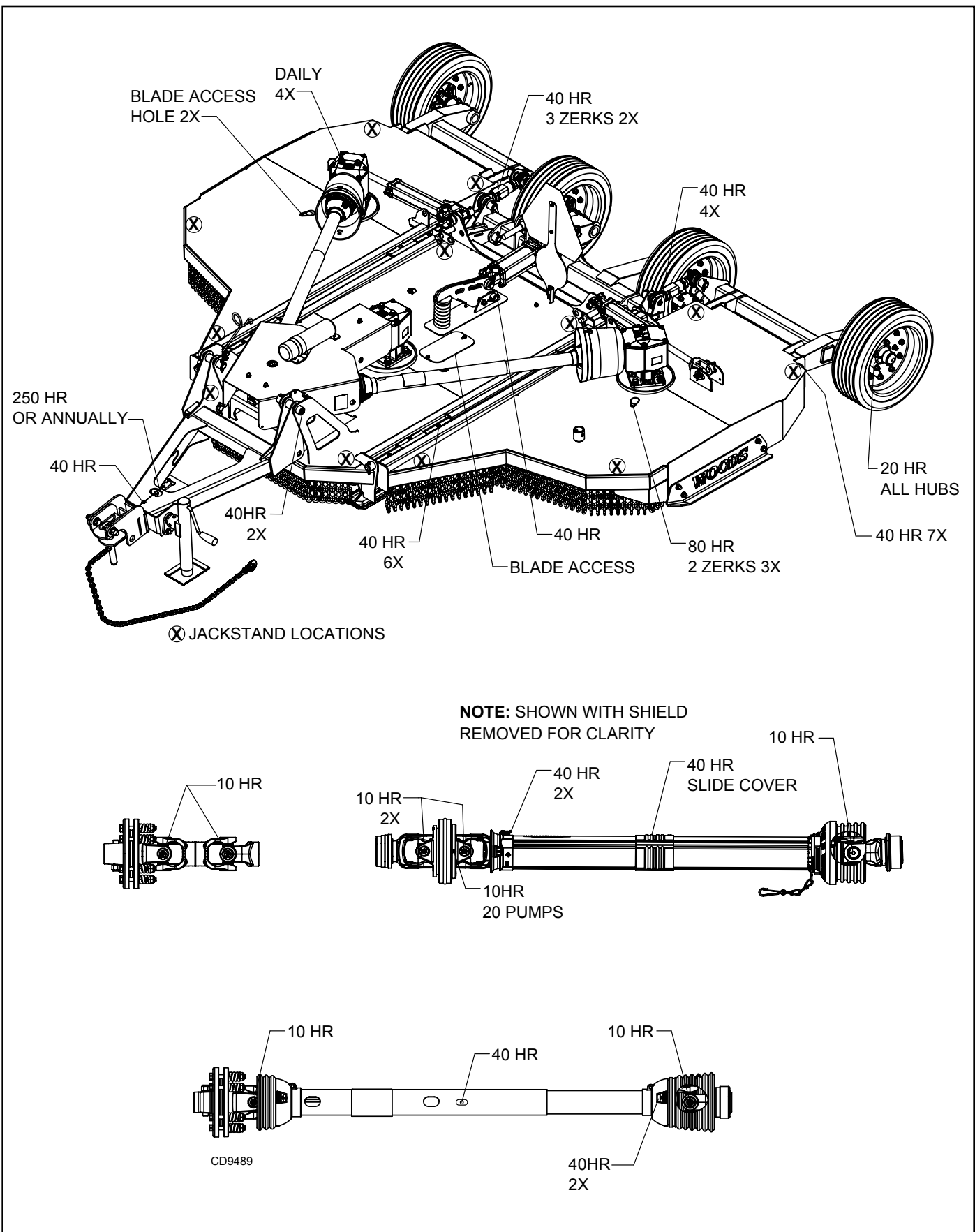

Figure 6. Jackstand Placement and Lubrication Points

LUBRICATION

Do not let excess grease collect on or around parts, particularly when operating in sandy areas.

See Figure 6 for lubrication points and frequency or lubrication based on normal operating conditions. Severe or unusual conditions may require more frequent lubrication.

Use a lithium grease of #2 consistency with a MOLY (molybdenum disulfide) additive for all locations unless otherwise noted. Be sure to clean fittings thoroughly before attaching grease gun. One good pump of most guns is sufficient when the lubrication schedule is followed.

Gearbox Lubrication

For gearbox, use a high quality gear oil with a viscosity index of 80W or 90W and an API service rating of GL-4 or -5 in gearboxes. Fill gearbox until oil is above lower line on dipstick. Check gearbox oil level daily for evidence of leakage, and contact your dealer if leakage occurs. Check vent plug periodically and clean if it does not relieve pressure.

Driveline Lubrication

1. Lubricate the driveline slip joint every eight operating hours. Failure to maintain proper lubrication could result in damage to U-joints, gearbox, and driveline.
2. With the cutter lowered to the ground, use the *SmartLift™* CV lift assist to support the input driveline and disconnect from the tractor PTO shaft.
3. Locate the grease access slot on the driveline shield and slide to cover to open.
4. Extend the driveline and rotate the shield to access the grease fitting, clean the fitting and apply 2 to 3 pumps of grease.
5. Grease the wing drivelines in the same way, but it is not necessary to disconnect when the wings are lowered to the ground.

Seasonal Lubrication

In addition to the daily recommended lubrication, a more extensive application is recommended seasonally.

1. Fill CV body with 20 pumps of grease with the joints in a straight line.
2. Articulate CV body to maximum angle several times to ensure full coverage of joints.
3. Place joints in the straight position and add 2 to 3 additional pumps of grease to both joints.
4. Wipe telescoping drive clean of all old grease and contaminants.
5. Add a thin layer of new grease over telescoping drive.
6. Clean and oil the exposed threads on each of the attitude rods.

MAN1405
(04/29/2026)

BLADES

⚠ WARNING

- Before working underneath, read manual instructions, securely block up, and check stability. Secure blocking prevents equipment from dropping due to hydraulic leak down, hydraulic system failure, or mechanical component failure.
- Do not handle blades with bare hands. Wear gloves. Careless or improper handling may result in injury.

Blade Removal (Figure 7)



Figure 7. Blade Assembly

1. Disconnect input driveline from tractor PTO.
2. Raise cutter and place 4 jack stands under center frame at locations marked "X" in Figure 6, and block securely.
3. Raise wings and engage transport lock pins.
4. Align hole in crossbar (4) with blade access hole in the cutter frame. Remove the bolt (1), using 3/4" wrench, blade pin lock clip (2) and keyhole plate (3). Carefully drive blade pin (6) out of crossbar and remove blade (5).
5. Rotate crossbar and repeat for opposite blade.

NOTICE

- If blade pin (6) is seized in crossbar and extreme force will be needed to remove it, support crossbar from below to prevent gearbox damage.

Owner Service 23

Blade Installation (Figure 7)

CAUTION

- Your dealer can supply genuine replacement blades. Substitute blades may not meet original equipment specifications and may be dangerous.
- Crossbar rotation has clockwise rotation on left gearbox and counterclockwise rotation on the right and center gearboxes when looking down on cutter. Be sure to install blade cutting edge to lead in correct rotation.
- Make sure that blade offset is oriented downward and that each blade freely swings all the way around when installed.

NOTE: Always replace or sharpen both blades at the same time.

1. Inspect blade pin (6) for nicks or gouges, and if you find any replace the blade pin.
2. Insert blade pin (6) through the blade (5). Blade should swivel on blade pin; if it doesn't, determine the cause and correct.
3. Align crossbar (4) with blade access hole in cutter frame. Make sure blade offset is down away from cutter.
4. Insert blade pin (6) through blade (5). Apply anti-seize compound to the blade pin and push through crossbar (4).
5. Assemble keyhole plate (3) into groove in blade pin (6).
6. Align keyhole plate (3) to tapped hole in crossbar (4) and assemble blade pin lock clip (2) into groove in blade pin (6).
7. Secure blade pin lock clip (2) with bolt (1). Torque bolt to 85 lbs-ft.

NOTE: Blade should be snug but should swivel on pin without having to exert excessive force. Blade should not move more than a 1/4 inch up or down at the tip. Shims are available to compensate for wear as needed. Use #10520RP - Blade Shim, .048" and #13946RP - Blade Shim, .036" as needed.

8. Grease pin via zerk at end of pin.
9. Repeat steps for opposite side.

Blade Sharpening

NOTICE

- When sharpening blades, grind the same amount on each blade to maintain balance. Replace blades in pairs. Unbalanced blades will cause excessive vibration, which can damage gearbox bearings. Vibration may also cause structural cracks to cutter.
 - Do not handle blades with bare hands. Wear gloves. Careless or improper handling may result in injury.
1. Sharpen both blades at the same time to maintain balance. Follow original sharpening pattern.
 2. Do not sharpen blade to a razor edge—leave at least a 1/16" blunt edge.
 3. Do not sharpen back side of blade.

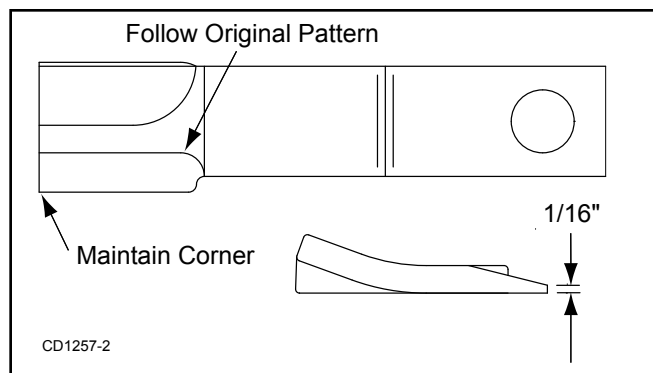

Figure 8. Blade Sharpening

SLIP CLUTCH ADJUSTMENT

(Figure 9)

The slip clutch is designed to slip so that the gearbox and driveline are protected if the cutter strikes an obstruction.

A new slip clutch or one that has been in storage over the winter may seize. Before operating the cutter, make sure it will slip by performing the following operation:

1. Turn off tractor engine and remove key.
2. Remove driveline from tractor PTO.

3. Access the spindle drivelines by removing the center gearbox shield.
4. Loosen six 10 mm cap screws (9) to remove tension from Pressure plate (7).
5. Hold flange yoke (1) solid and turn shaft to make sure clutch slips.
6. If clutch does not slip freely, disassemble and clean the flanged hub faces (4), internal disc (6), and flanged hub (1).
7. Reassemble clutch.
8. Reassemble clutch and tighten bolts (9) no more than 1/8 of a turn at a time until desired setting of 1.12" is reached as shown in Figure 9.
9. If a clutch continues to slip check friction discs (3) for excessive wear. Discs are 1/8" when new. Replace discs after 1/16" wear. Minimum disc thickness is 1/16".

SHIELDING REPAIR

! DANGER

- Full chain shielding must be installed at all times. Thrown objects could injure people or animals or damage property.
 - If the machine is not equipped with full chain shielding, operation must be stopped.
 - This shielding is designed to reduce the risk of thrown objects. The mower deck and protective devices cannot prevent all objects from escaping the blade enclosure in every mowing condition. It is possible for objects to ricochet and escape, traveling as much as 300 feet (92m).

Repairing Chain Shielding

1. Inspect chain shielding each day of operation and replace any broken or missing chains as required.
2. Replace any missing hardware.

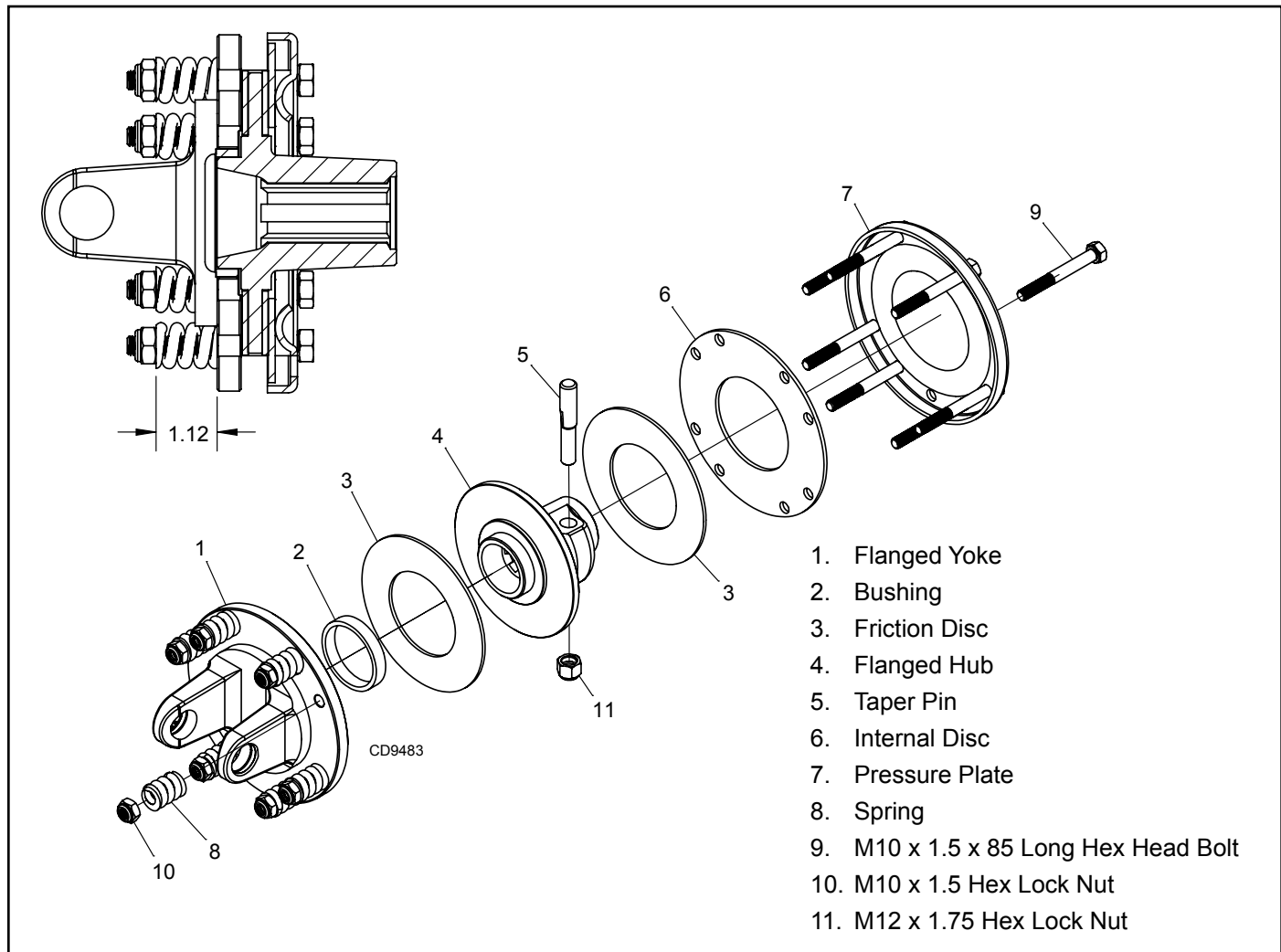
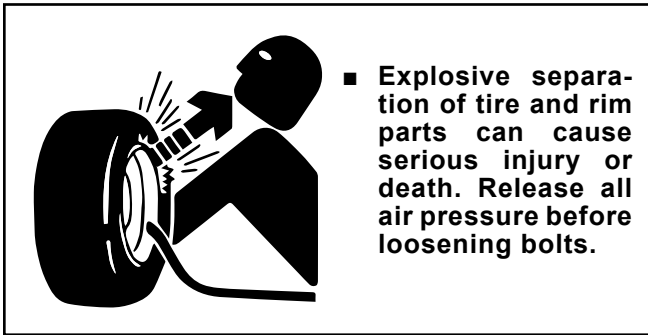

Figure 9. Slip Clutch Assembly

SERVICING TIRES SAFELY

Split Rim Tires (Figure 10)

⚠ WARNING



- Do not attempt to mount a tire unless you have the proper equipment and experience to perform the job.
- Always maintain the correct tire pressure. Do not inflate pneumatic tires above 40 psi. Never weld or heat a wheel and tire assembly. The heat can cause an increase in air pressure and result in a tire explosion. Welding can structurally weaken or deform the wheel.
- When inflating tires, use a clip-on chuck and an extension hose long enough to allow you to stand to the side — not in front of or over the tire assembly. Use a safety cage if available.
- Check wheels for low pressure, cuts, bubbles, damaged rims, or missing lug bolts and nuts.
- Never remove split rim assembly hardware (A) with the tire inflated.

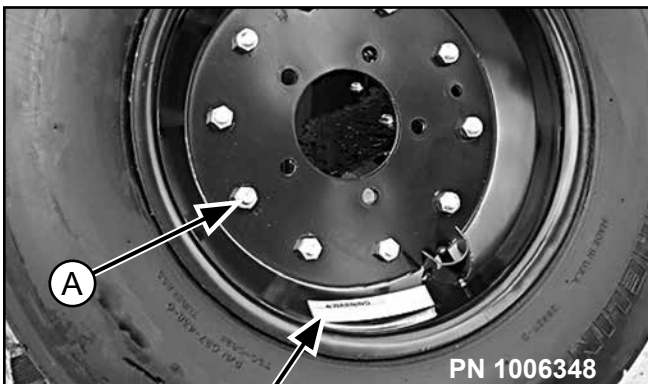

⚠ WARNING

EXPLOSION HAZARD

RELEASE ALL AIR PRESSURE BEFORE LOOSENING BOLTS. FAILURE TO DO SO COULD RESULT IN SERIOUS INJURY OR DEATH. MAX. SPEED: 20 MPH, MAX. WEIGHT: 4000 LBS., MAX. AIR PRESSURE: 40 PSI.

1006348 A/B

CLEANING

⚠ CAUTION

- Wear long sleeves, long pants, boots, and gloves when cleaning machine to avoid contact with poisonous plants.
- Wear safety glasses or goggles and a dust mask. Use a leaf-blower, or broom to remove debris without damaging decals, hoses or wiring.

After Each Use

- Remove large debris such as clumps of dirt, grass, crop residue, etc. from machine.
- Inspect machine and replace worn or damaged parts.
- Replace any safety decals that are missing or not readable (supplied free by your Woods dealer).

Periodically or Before Extended Storage

- Clean debris such as clumps of dirt, grass, crop residue, etc. from machine and remove buildup of grease, or oil.
- Remove the remainder using a low-pressure water spray.
- Be careful when spraying near scratched or torn safety decals or serial tag or near edges of decals as water spray can peel decal off surface.
- Be careful when spraying near chipped or scratched paint as water spray can lift paint.
- If a pressure washer is used, follow the advice of the pressure washer manufacturer.
- Inspect machine and replace worn or damaged parts.
- Sand down scratches and the edges of areas of missing paint and coat with Woods spray paint of matching color (purchase from your Woods dealer).
- Replace any safety decals that are missing or not readable (supplied free by your Woods dealer). See Safety & Instructional Decals section for location drawing.

Figure 10. Split Rim Tire Servicing

TROUBLESHOOTING

PROBLEM	POSSIBLE CAUSE	SOLUTION
Does not cut	Dull blades Worn or broken blades Incorrect PTO speed Ground speed too fast Drive not functioning (blades do not turn when PTO is running) Gearbox malfunction Excessive clutch slippage Incorrect blade direction	Sharpen blades. Replace blades. (Replace in pairs only.) Set at rated PTO speed. Reduce ground speed. Check drive shaft connection. Check gearbox. Repair gearbox. Adjust clutch. Check to be sure blade edge is correct for direction of rotation.
Streaks or ragged cut	Broken or worn blades Attitude incorrect Ground speed too fast Excessive cutting height Excessive lush and tall vegetation	Replace or sharpen blades. Level machine. Reduce ground speed. Lower cutting height. (Note: Set height so blades do not frequently hit ground.) Recut at 90° to first pass.
Excessive side skid wear	Running with skids continuously on ground	Raise cutting height or adjust.
Excessive clutch slippage	Clutch out of adjustment Clutch discs worn; wear stops contacting opposite plate Blades hitting ground	Adjust clutch. Replace discs. Raise cutting height.
Vibration	Broken blade Bearing failure Hitch length incorrect	Replace blades in pairs. Check gearbox shafts for side play. Reset hitch length.
Blades hitting deck	Bent blades or crossbar	Replace bent blades or crossbar.
Unit will not raise	Low oil	Add hydraulic oil.
Unit doesn't cut level	Wing section cuts lower than center Wing section cuts higher than center	Lengthen turnbuckle connecting center yoke to wing wheel yoke. Shorten turnbuckle connecting center yoke to wing wheel yoke.

DEALER SERVICE

The information in this section is written for dealer service personnel. The repair described here requires special skills and tools. If your shop is not properly equipped or your mechanics are not properly trained in this type of repair, you may be time and money ahead to replace complete assemblies.

⚠ WARNING

- Before performing any service or maintenance, follow these steps:
 - Disengage power to equipment and wait for all moving parts to stop.
 - Lower all raised components to the ground and operate valve levers to release any hydraulic pressure.
 - Place all controls in neutral and set parking brake.
 - Stop tractor engine, remove ignition key and unfasten seat belt.
- Before working underneath, read manual instructions, securely block up, and check stability. Secure blocking prevents equipment from dropping due to hydraulic leak down, hydraulic system failure, or mechanical component failure.
- Keep all persons away from operator control area while performing adjustments, service, or maintenance.

⚠ CAUTION

- Always wear relatively tight and belted clothing to avoid getting caught in moving parts. Wear safety glasses or goggles, sturdy, rough-soled work shoes, gloves, and hearing protection. Respiratory protection may be required, depending on the work.

GEARBOX MAINTENANCE

NOTE: Read this entire section before starting any repair. Many steps are dependent on each other.

1. Fill gearbox with SAE 80W or 90W gear lube with an API service rating of GL-4 or GL-5. Proper oil level is between lowest ring and end of dipstick.

NOTE: Repair to this gearbox is limited to replacing bearings and seals. Replacing gears, shafts, and a housing is not cost effective. Purchasing a complete gearbox is more economical.

2. Inspect gearbox for leakage and bad bearings. Leakage is a very serious problem and must be corrected immediately.

NOTE: Bearing failure is indicated by excessive noise and side-to-side or end-play in gear shafts.

Seal Replacement (Figure 11)

Recommended sealant for gearbox repair is Permatex® Aviation 3D Form-A-Gasket or equivalent.

Leakage can occur at the shaft seals.

Leakage at the horizontal seal can be repaired without removing the gearbox from the cutter.

Seal Installation

NOTE: Proper seal installation is important. An improperly installed seal will leak.

1. Clean area in housing where seal outer diameter (OD) seats. Apply a thin coat of Permatex.
2. Inspect area of shaft where seal seats. Remove any burrs or nicks with an emery cloth.
3. Lubricate gear shaft and seal lips.
4. Place seal squarely on housing, spring-loaded lip toward housing. Select a piece of pipe or tubing with an OD that will sit on the outside edge of the seal but will clear the housing. Tubing with an OD that is too small will bow seal cage and ruin seal.
5. Carefully press seal into housing, avoiding distortion to the metal seal cage.

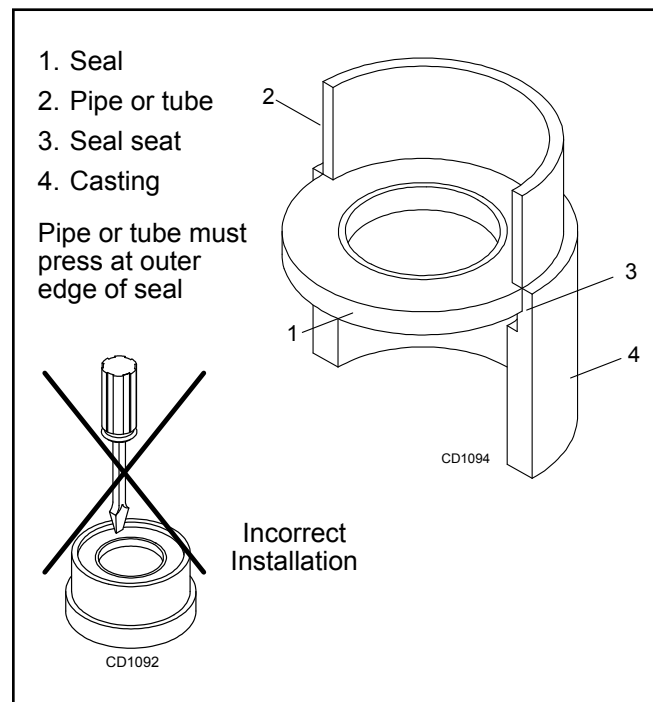

Figure 11. Seal Installation

GEARBOX REPAIR

Removal from Cutter (Figure 12)

WARNING

- **Gearboxes are heavy and can cause muscle strain or back injury. Use lifting aids and proper lifting techniques when handling.**
- 1. Disconnect and remove the rear driveline from the gearbox.
- 2. Remove cotter pin and nut from vertical shaft and remove crossbar (see page 33).
- 3. Remove the four bolts that attach gearbox to cutter and remove gearbox.

Disassemble Gearbox

1. Remove plug from side of gearbox and pour out remaining gear oil.
2. Support housing in vise in a vertical position.
3. Remove input seal (4) (to be replaced).
4. Remove retaining rings (6) and (8).
5. Remove the six cap screws (24), washers (23) and top cover (2) from housing.
6. Remove retaining ring (6) behind gear (3).
7. Support gearbox in hand press and pull input shaft (5) through gear (3). Remove ball bearing (20).
8. Remove ball bearing (21) and gear spacer (7) from input shaft (5).
9. Support housing in vise in a horizontal position.
10. With the hub/stump jumper/crossbar, castle nut, cotter pin, wire and washer already removed, remove the four cap screws (13), lock washers (12) and output cap (17).
11. Remove output gaskets (11) and (10).
12. Push output shaft and pinion (19) down and remove ball bearing (20) or tapered roller bearings (25), output bearing spacer (18), and retaining ring (6). Remove output shaft and pinion (19).
NOTE: On gearboxes with tapered roller bearings, it will be necessary to use a punch to drive out bearing cups.
13. Inspect gears for broken teeth and wear. Some wear is normal and will show on loaded side. Forged gear surfaces are rough when new. Check that wear pattern is smooth.
14. Inspect vertical and horizontal shafts for grooves, nicks, or bumps in the areas where the seals seat. Resurface any damage with emery cloth.
15. Inspect housing and caps for cracks or other damage.

SEAL REPAIR

Refer to Figure 12.

Vertical Shaft Seal Repair

1. Disconnect and remove the rear driveline from the gearbox.
2. Remove vent plug (9) and siphon gear lube from housing through this opening.
3. Remove crossbar (see Crossbar Removal, page 28).
4. Remove output cap (17) and output seal (16) by removing four cap screws (13) and washers (12). Replace with new seal (see Seal Installation, page 23).

Vertical seal should be recessed in output cap.

NOTE: Distortion to seal cage or damage to seal lip will cause seal to leak.

5. Secure output cap (17) on to bottom of gearbox using four cap screws (13) and lock washers (12).
NOTE: Make sure output gasket (10) and (11) are in place.
6. Fill gearbox with SAE 80W or 90W gear lube until it runs out the side level plug.
7. Remove and replace any seal damaged in installation.

Horizontal Seal Leak Repair

1. Disconnect and remove the rear driveline from the gearbox.
2. Remove vent plug (9) and siphon gear lube from housing through this opening.
3. Remove input seal (4). Replace with new one (refer to Seal Installation, page 23).

Fill gearbox with SAE 80W or 90W gear lube until it runs out the side level plug.

Reassemble Gearbox

1. Clean housing, paying specific attention to areas where gaskets will be installed.
2. Wash housing and all components thoroughly. Select a clean area for gearbox assembly. Replace all seals, bearings, and gaskets. All parts must be clean and lightly oiled before reassembling.
3. Insert upper output bearing cups (25) in the housing and press using a round tube with the correct diameter.
4. Slide shims (26) over output shaft (16). Use the same thickness as removed as a starting point.
5. Push bearing cone (25) onto output shaft (16). Shims maybe required between cone (25) and retaining ring (6) to eliminate any space.

NOTE: Make sure there is no endplay or gaps in this assembly.

6. Insert output bearing spacer (18) and bearing cone (25) over output shaft until seats against upper bearing (25). Press lower bearing cup into position as shown.
7. Secure output cap (17) with new output seal (16) installed to bottom of gearbox housing using the four 10mm x 1.5 x 25 cap screws (13) and lock washers (12). Use shim gaskets (10) and (11) to adjust output bearings to a rolling torque of 9 to 12 In-lbs.

NOTE: Be sure output gaskets (10 and 11) are in place. Apply grease to output seal (16) lip for easy installation.

8. Place ball bearing (21) at back of housing and press in socket using a round tube of the correct diameter and a hand press until fully seated.
9. Insert input shaft (5) part way through housing and slide gear (3) and retaining ring (6) over input shaft (5). Keep gear (3) and retaining ring (6) loose.
10. Insert input shaft (5) into roller bearing (21) until seated against each other.
11. Slide gear (3) forward and attach retaining ring (6) in groove closest to front of input shaft (5). Slide gear (3) back against retaining ring (6).

12. Check that the gear backlash is between 0.006" and 0.016". You should not have to adjust the backlash.
13. Slide gear spacer (7) and ball bearing (21) on input shaft (5) and secure with retaining rings (6) and (8).
14. Slide input seal (4) onto input shaft (5) and press into housing flush with front using a tube of correct diameter. Be careful not to damage seal lip.
15. Check gearbox housing for leaks by plugging all holes except one. Apply 4 psi compressed air and immerse the gearbox in water to verify that there are no leaks. Remove gearbox from water and dry off with compressed air. Add SAE 80W or 90W EP oil until it runs out of side level hole. Tighten all plugs.

Reinstallation

⚠ WARNING

- Gearboxes are heavy and can cause muscle strain or back injury. Use lifting aids and proper lifting techniques when handling.

1. Set gearbox on cutter and fasten with bolts and nuts. Torque bolts to 175 lbs-ft.
2. Attach crossbar (Crossbar Installation, page 34).

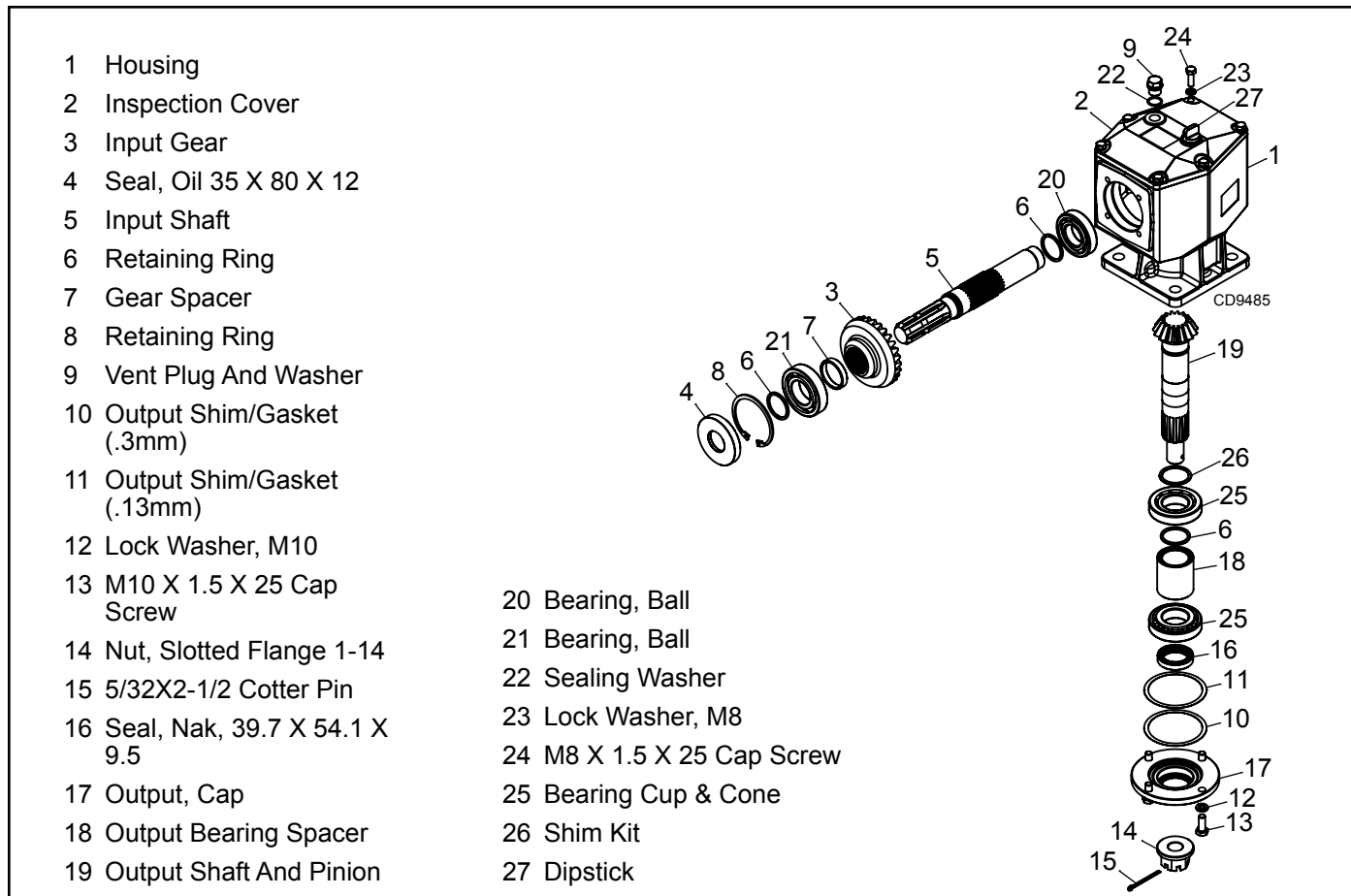

Figure 12. Gearbox

30 Dealer Service

MAN1405
(04/29/2026)

SPLITTER GEARBOX REPAIR

(Figure 13)

Removal from Cutter

⚠ WARNING

- **Gearboxes are heavy and can cause muscle strain or back injury. Use lifting aids and proper lifting techniques when handling.**

1. Disconnect and remove all drivelines from gearbox.
2. Remove the four cap screw and lock washers that secure gearbox to cutter, and remove gearbox.

Disassembly

Center Shaft

1. Remove plug (3) from side of gearbox and pour out the gear oil. Replace plug after draining.
2. Remove seal (11, to be replaced) from the front and rear of the center shaft (14).
3. Remove snap ring (10) and shim (12) from the front and rear of the center shaft (14).
4. Support gearbox in a hand press and push on the rear of the center shaft.
5. Remove bearing (13) from center shaft (14).
6. Remove six cap screws (19) and top cover (18) from the gearbox housing.
7. Remove gear (15) and bearing (13).

Side Shaft

8. Remove seal (2, to be replaced) from the output shaft (1).
9. Remove snap ring (4) and shim (8) from output shaft (1).
10. Support gearbox in hand press. Using a punch through the front opening of the gearbox and, push shaft (1) and bearing (5) out the backside of housing.
11. Remove gear (6) from inside housing.
12. Snap ring (21) does not have to be removed from shaft (1) unless it is damaged.
13. Remove bearing (7) and shim (8) by using a hammer and punch through front opening of the gearbox and force them out the backside of the housing.
14. Repeat steps 9 through 14 for opposite side shaft.

Inspect Components

15. Inspect gears for broken teeth and wear. Some wear is normal and will show on the loaded side of the teeth. Forged gear surfaces are rough when new. Check that wear pattern is smooth.

16. Inspect shafts for grooves, nicks, or bumps in the areas where seals seat. Resurface any damage with emery cloth or replace shaft. from gearbox.
17. Inspect housing and caps for cracks or other damage.

Assembly

1. Clean housing, pay specific attention to areas where gaskets are installed.
2. Wash housing and all components thoroughly.
3. Select a clean work area to assemble gearbox.
4. Replace all seals and bearings.
5. All parts must be clean and lightly oiled before assembly.

Side Shaft

6. Insert bearing (7) and shim (8) in housing using a round tube of the same size diameter and a hand press.
7. Place gear (6) inside the housing and slide output shaft (1) through gear (6) and into bearing (7).
8. Slide bearing (5) and shim (8) over output shaft. Secure with snap ring (4).
9. Check end play of shaft by moving it in and out. If end play is more than 0.012", insert another shim (8) between snap ring and bearing. Repeat process until end play is less than 0.012".
10. Check rotational torque. Torque should be less than 2.2 lbs-inch gear.
11. Place seal (2) over shaft and press into housing using a tube of the same diameter. Seal should be flush with housing when properly installed.
12. Repeat steps 6 through 11 for opposite side shaft.

Center Shaft

13. Place gear (15) inside housing and slide center shaft (14) through the gear from the front of the housing.
14. Slide bearings (13) and shims (12) over each end of the center shaft (14). Secure bearings into position using snap rings (10).
15. Check end play of shaft by moving it in and out. If end play is more than 0.012", insert another shim (12) between snap ring and bearing. Repeat process until end play is less than 0.012".
16. Check rotational torque. Torque should be less than 2.2 lbs-inch gear.
17. Check gear backlash, backlash should be between 0.006" and 0.016". You should not have to adjust for backlash.
18. Place seal (11) over shaft and press into housing using a tube of the same diameter. Seal should be flush with housing when properly installed. Repeat process for opposite end shaft.

Check Gearbox

1. Apply Permatex® Aviation 3D Form-A-Gasket or equivalent sealant to top of housing. Place top cover (18) on housing and secure into position using six cap screws (19).
2. Check gearbox for leaks by: plugging all holes except one, applying 4 psi of compressed air, and immersing gearbox in water. Verify gearbox does not leak.

NOTE: Excessive air pressure will damage seals.

3. Remove gearbox from water and dry off.
4. Remove upper plug (3) on right side of housing. Add SAE 80W or 90W (API GL-4 or GL-5) gear lube until it runs out side level hole. Replace plug.
5. Install dipstick (17) and washer (16) in top cover.

Reinstallation on Cutter

WARNING

- Gearboxes are heavy and can cause muscle strain or back injury. Use lifting aids and proper lifting techniques when handling.

1. Place gearbox on cutter and secure into position using four cap screws and lock washers.
2. Torque hardware to 175 lbs-ft.
3. Attach all drivelines to gearbox.
4. Install all shields.

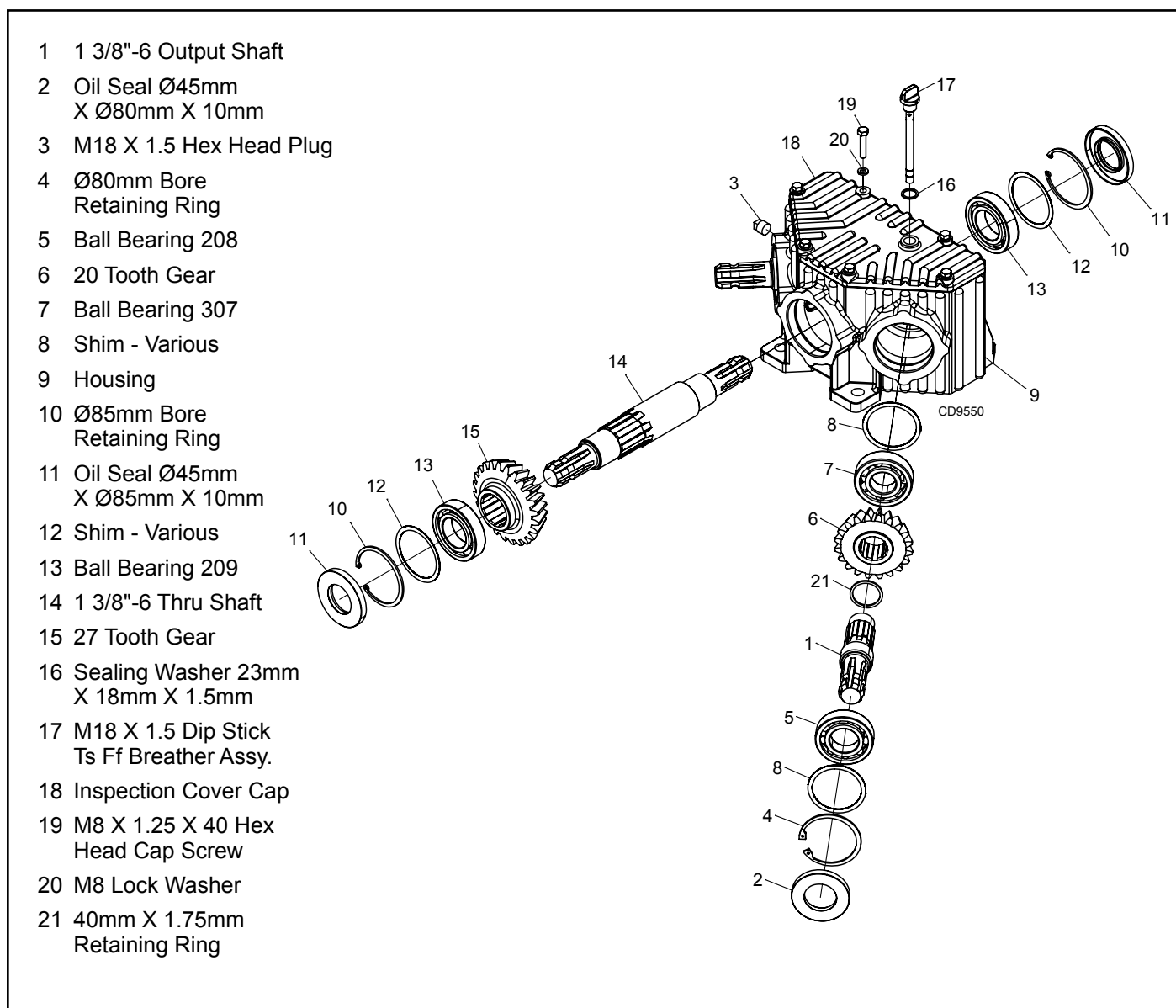

Figure 13. Splitter Gearbox Assembly

32 Dealer Service

MAN1405
(04/29/2026)

CROSSBAR REMOVAL

⚠ WARNING

- **Crossbars are heavy and can cause muscle strain or back injury. Use lifting aids and proper lifting techniques when handling.**
1. It is necessary to gain access to bottom side of cutter for crossbar removal. See Blocking Method page 21.
 2. Blade removal is not required when removing crossbar. If desired, the blades can be removed as shown in Figure 14.

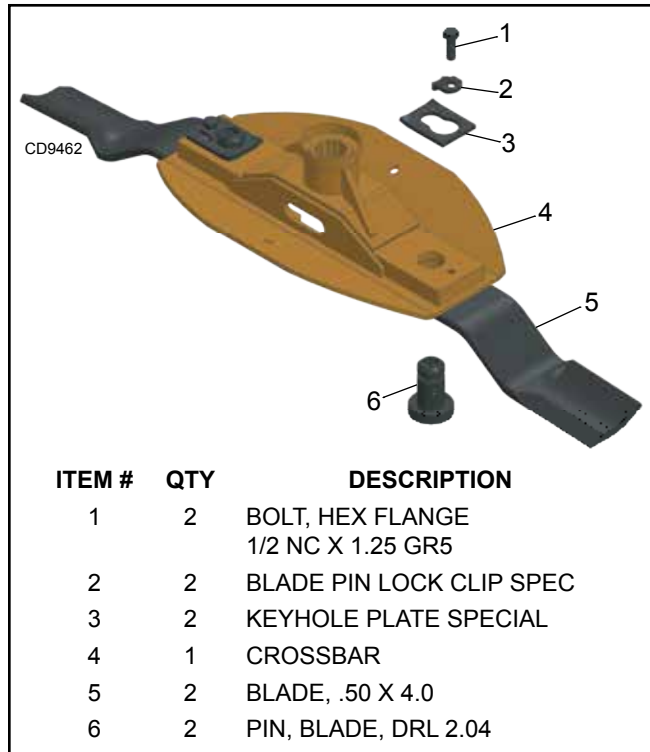

Figure 14. Blade Removal

3. Refer to Figure 15. Remove cotter pin from bottom of crossbar and remove nut and washer.
4. Support cutter as shown in Figure 6.
5. Place two 4 x 4 wood blocks approximately 2" below and perpendicular to crossbar. This helps keep crossbar hub clean when it comes off gearbox shaft.
6. Remove access cover on top of deck (center section). The access hole should be used on the wings. Use a heavy punch and hammer or large slide hammer and drive crossbar off of gearbox shaft. Rotate the crossbar 180 degrees after 5 hits and repeat.
7. When hitting crossbar, take care not to damage any of the blade retaining hardware.

CROSSBAR INSTALLATION

1. Using emery cloth (220 or finer), remove surface rust, Loctite® and foreign material from hub, splined gearbox vertical shaft, and crossbar assembly.
2. Apply anti-sieze compound to splines and slide crossbar assembly onto splined shaft. Install washer and nut and align a slot with hole in splined shaft. Torque nut to 450 lbs-ft.
3. Install cotter pin through slot in nut and bend ends over.

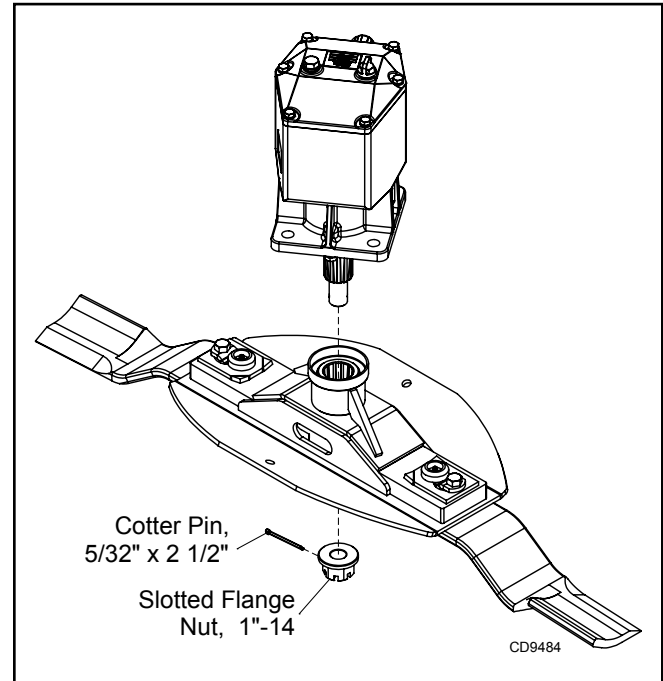

Figure 15. Crossbar Assembly Installation

UNIVERSAL JOINT REPAIR

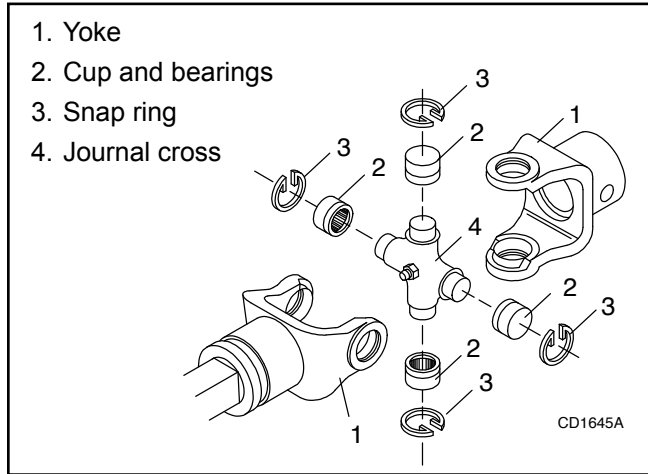

Figure 16. U-Joint Exploded View

U-Joint Disassembly

1. Remove external snap rings from yokes in four locations as shown in Figure 17.

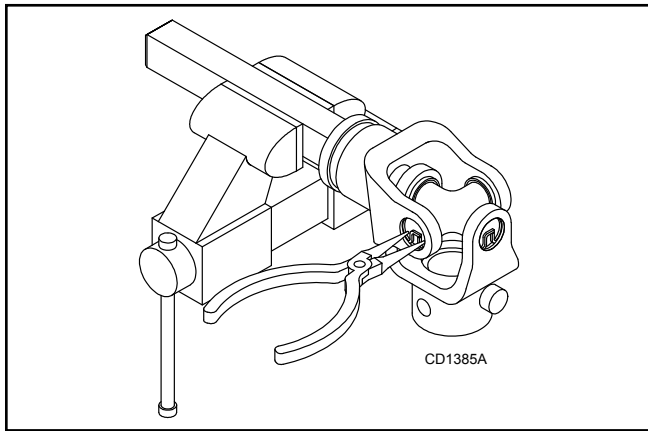

Figure 17.

2. With snap rings removed, support drive in vise, hold yoke in hand and tap on yoke to drive cup up out of yoke. See Figure 18.

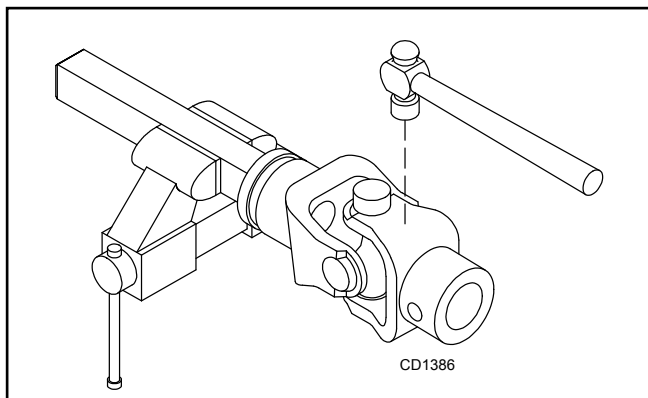

Figure 18.

3. Clamp cup in vise as shown in Figure 19 and tap on yoke to completely remove cup from yoke. Repeat Step 2 & Step 3 for opposite cup.

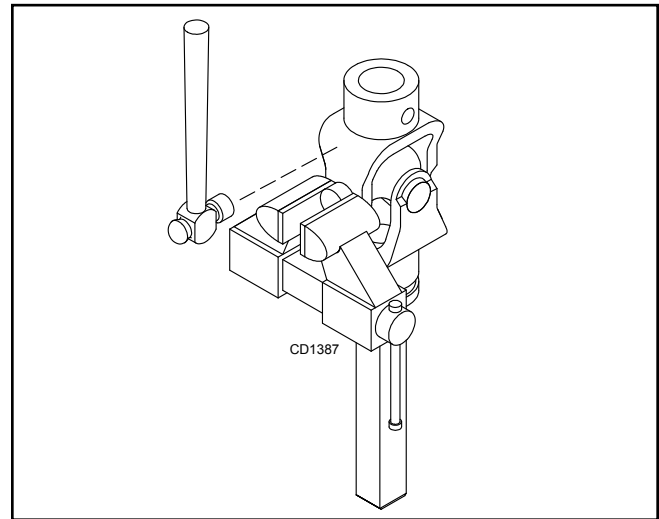

Figure 19.

4. Place universal cross in vise as shown in Figure 20 and tap on yoke to remove cup. Repeat Step 3 for final removal. Drive remaining cup out with a drift and hammer.

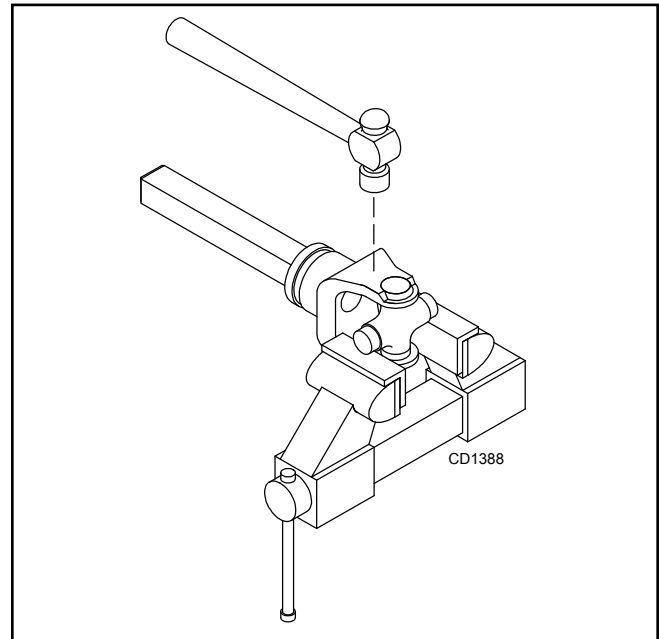

Figure 20.

U-Joint Assembly

1. Place seals securely on bearing cups. Insert cup into yoke from outside and press in with hand pressure as far as possible. Insert journal cross into bearing cup with grease fitting away from shaft. Be careful not to disturb needle bearings. Insert another bearing cup directly across from first cup and press in as far as possible with hand pressure.
2. Trap cups in vise and apply pressure. Be sure journal cross is started into bearings and continue pressure with vise, squeezing in as far as possible. Tapping the yoke will help.
3. Seat cups by placing a drift or socket (slightly smaller than the cup) on cup and rap with a hammer. See Figure 20. Install snap ring and repeat on opposite cup.
4. Repeat Step 1 and Step 2 to install remaining cups in remaining yoke.
5. Move both yokes in all directions to check for free movement. If movement is restricted, rap on yokes sharply with a hammer to relieve any tension. Repeat until both yokes move in all directions without restriction.

SERVICING TIRES SAFELY

Split Rim Tires (Figure 21)

WARNING

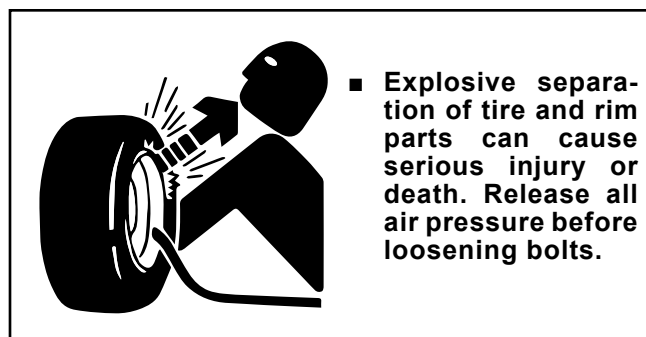

Do not attempt to mount a tire unless you have the proper equipment and experience to perform the job.

Always maintain the correct tire pressure. Do not inflate pneumatic tires above 40 PSI. Never weld or heat a wheel and tire assembly. The heat can cause an increase in air pressure and result in a tire explosion. Welding can structurally weaken or deform the wheel.

When inflating tires, use a clip-on chuck and an extension hose long enough to allow you to stand to the side — not in front of or over the tire assembly. Use a safety cage if available.

Check wheels for low pressure, cuts, bubbles, damaged rims, or missing lug bolts and nuts.

Never remove split rim assembly hardware (A) with the tire inflated.



Figure 21. Split Rim Tire Servicing

ASSEMBLY INSTRUCTIONS

DEALER SET-UP INSTRUCTIONS

Assembly of this cutter is the responsibility of the WOODS dealer. It should be delivered to the owner completely assembled, lubricated and adjusted for normal cutting conditions.

The cutter is shipped partially assembled. Assembly will be easier if components are aligned and loosely assembled before tightening hardware. Recommended torque values for hardware are located on page 57.

Select a suitable working area. A smooth hard surface, such as concrete, will make assembly much quicker. Open parts boxes and lay out parts and hardware to make location easy. Refer to illustrations, accompanying text, parts lists and exploded view drawings.

Complete the checklist on page 38 when assembly is complete and cutter is delivered to the customer.

⚠ WARNING

- Before working underneath, carefully read Operator's Manual instructions, disconnect driveline, raise mower, securely block up all corners with jackstands, and check stability. Secure blocking prevents equipment from dropping due to hydraulic leak down, hydraulic system failures, or mechanical component failures.
- Do not disconnect hydraulic lines until engine is stopped, power unit is properly secured, equipment and all components are lowered to the ground, and system pressure is released by operating all valve control levers.

⚠ CAUTION

- Always wear relatively tight and belted clothing to avoid getting caught in moving parts. Wear safety glasses or goggles, sturdy, rough-soled work shoes, gloves, and hearing protection. Respiratory protection may be required, depending on the work.

Install Wheel

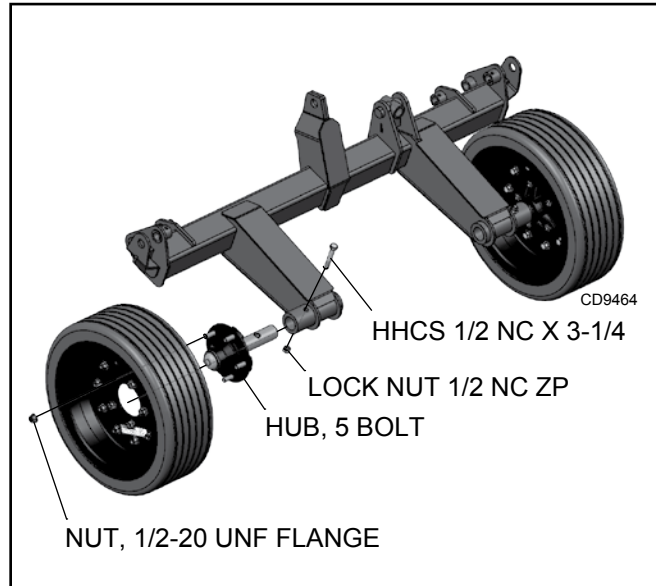

Figure 22. Center Section Wheel and Hub Installation

Install Wing Wheel

(Figure 23)

⚠ WARNING

- Wheel assemblies are heavy and can cause muscle strain or back injury. Use lifting aids and proper lifting techniques when handling.
1. Raise mower to max height and insert transport lock pin. (Fig 3, page 19)
 2. Insert wheel hub into wing wheel yoke arms and align holes.
 3. Secure into position using cap screw and lock nut.
 4. Attach wheel to hub using five flanged nuts. Tighten to 85 lbs-ft. Check that tire air pressure is a maximum of 40 psi.

NOTE: Notat, (laminated), severe-duty ag, and used aircraft tires are available. See page 55 for parts list.



Figure 23. Wing Wheel - Right

Install Driveline

⚠ WARNING

- Driveline is heavy and can cause muscle strain or back injury. Use lifting aids and proper lifting techniques when handling.

1. Cut bands and remove driveline from wing.
2. Pull back quick release collar.
3. Slide driveline yoke onto gearbox input shaft until quick release collar clicks into place.

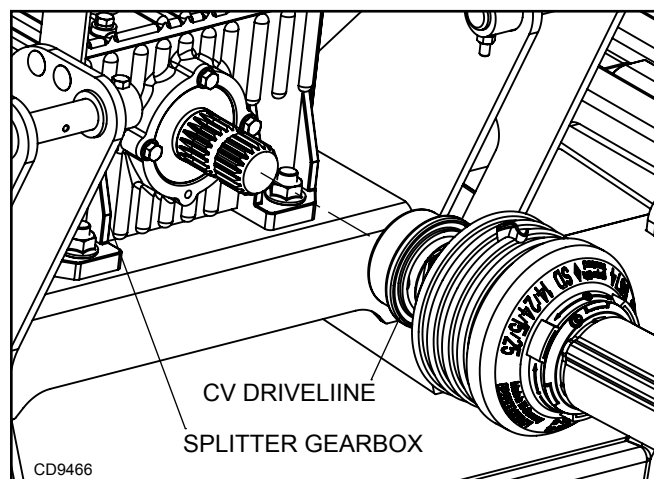

Figure 24. Driveline Installation

Remove Shipping Brackets

1. Loosen nut and remove both shipping brackets from right wing skid.
2. Re-tighten nut and torque to 85 ft-lbs.

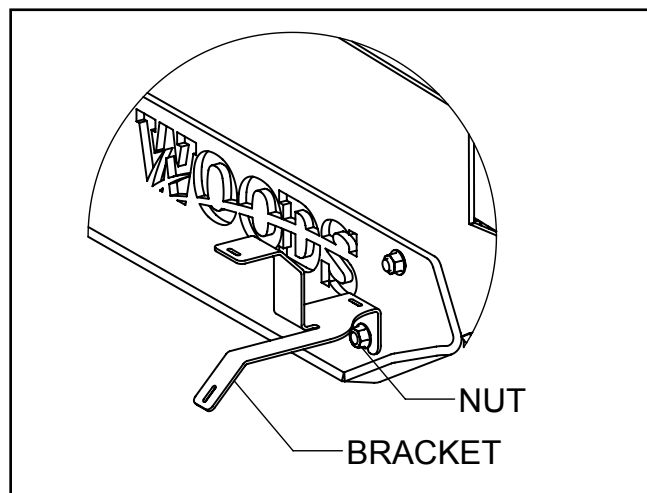

Figure 25. CV Bracket

- 3.

DEALER CHECKLISTS

DEALER PRE-DELIVERY CHECKLIST

(DEALER'S RESPONSIBILITY)

Inspect the equipment thoroughly after assembly to ensure it is set up properly before delivering it to the customer.

The following checklists are a reminder of points to inspect. Check off each item as it is found satisfactory or after proper adjustment is made.

- _____ Check that all safety decals are installed and in good condition. Replace if damaged.
- _____ Check that shields and guards are properly installed and in good condition. Replace if damaged.
- _____ Check all bolts to be sure they are properly torqued.
- _____ Check wheel bolts for proper torque.
- _____ Check that all cotter pins and safety pins are properly installed. Replace if damaged.
- _____ Check that blades have been properly installed.
- _____ Check and grease all lubrication points as identified in lubrication information on page 22.
- _____ Check the level of gearbox fluids before delivery. Service, if required, as specified in the lubrication information on page 23.
- _____ Show customer how to use the *SmartLift*™ CV lift assist and point out that it must be folded down for rotary cutter operation.

DELIVERY CHECKLIST

(DEALER'S RESPONSIBILITY)

- _____ Show customer how to make adjustments and select proper PTO speed.
- _____ Show customer how to make sure driveline is properly installed and that spring-activated locking pin or collar slides freely and is seated in groove on tractor PTO shaft.
- _____ Show customer how to determine the turning limits of the CV PTO driveline.
- _____ Show customer the safe, proper procedures to be used when mounting, dismounting, and storing equipment.
- _____ Make customer aware of optional equipment available so that customer can make proper choices as required.
- _____ Instruct customer how to lubricate and explain importance of lubrication.
- _____ Point out the safety decals. Explain their meaning and the need to keep them in place and in good condition. Emphasize the increased safety hazards when instructions are not followed.
- _____ Explain to customer that when transporting the cutter, the wing and center sections should be raised and their respective transport bars installed and pinned in place.
- _____ Present Operator's Manual and request that customer and all operators read it before operating equipment. Point out the manual safety rules, explain their meanings and emphasize the increased safety hazards that exist when safety rules are not followed.
- _____ Explain to customer the potential crushing hazards of going underneath raised equipment. Instruct that before going underneath to disconnect the driveline, securely block up all corners with jack stands and to follow all instructions in the BLOCKING METHOD, page 21 of the operator's manual. Explain that blocking up prevents equipment dropping from hydraulic leak down, hydraulic system failures or mechanical component failures.
- _____ Point out all guards and shields. Explain their importance and the safety hazards that exist when not kept in place and in good condition.
- _____ Explain to customer to comply with all state and local lighting and marking laws, to turn on flashing warning lights before traveling on a public roadway, and to use the safety tow chain.



BATWING® Rotary Cutter

BW10.30

BW10.30 CENTER FRAME ASSEMBLY	40
BW10.30 WING ASSEMBLY	41
BW10.30 WHEEL ARM, RIGID	42
HOSE SUPPORT, SKIDS & MISCELLANEOUS.	43
TONGUE ASSEMBLY	44
SMARTLIFT™ CV LIFT ASSIST AND HOSE HOLDER (OPTIONAL)	45
BW10.30 WING & CENTER GEARBOX ASSEMBLY	46
BW10.30 SPLITTER GEARBOX ASSEMBLY	47
BW10.30 CENTER DECK DRIVE ASSEMBLY	48
BW10.30 WING DRIVE ASSEMBLY	49
CV DRIVE ASSEMBLY.	50
LIGHTS AND WIRING (OPTIONAL)	51
CHAIN SHIELDING	52
CYLINDER AND HOSE ASSEMBLY.	53
HYDRAULIC CYLINDERS	54
WHEEL AND TIRE ASSEMBLIES	55
ATTITUDE ROD	56

BW10.30 CENTER FRAME ASSEMBLY

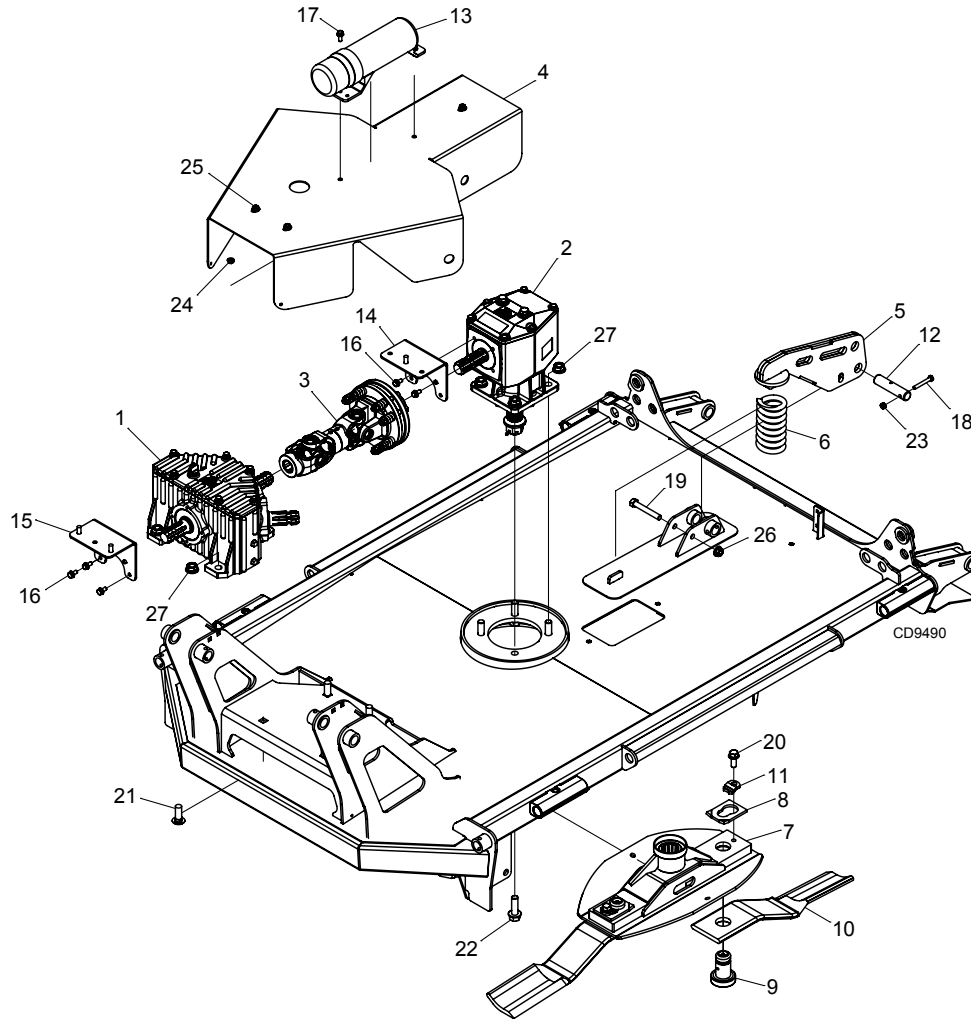

REF	QTY	PART	DESCRIPTION	REF	QTY	PART	DESCRIPTION
1	1	651172	GEARBOX, SPLITTER 1:1.35, OIL	16	5	1041071	BOLT, HEX FLNG M8 X16 CL8.8, DRI-LOC
2	1	617198RP	GEARBOX, REPAIR CCW 1:1.93 W/BAG	17	2	71851	BOLT, HEX FLNG 5/16 NC X .75 GR5
3	1	651170	DRIVELINE, CMPL 15.74	18	1	7164	HHCS 5/16 NC X 2-1/4 GR5
4	1	651135RP	SHIELD, CENTER	19	1	1637	BOLT, HEX 1/2 NC X 3.50 GR5
5	1	651142RP	SPRING ARM	20	2	1031225	BOLT, HEX FLNG 1/2 NC X 1.25 GR5
6	1	13316	SPR/CMP 3.00 .50 6.2	21	4	33034	BOLT CRG 5/8 NC X 1-3/4 GR5 ZP
7	1	651168RP	CROSSBAR	22	4	1038890	HFS 5/8 NC X 2 GR8
8	2	32603	KEYHOLE PLATE SPECIAL	23	2	6778	NUT LOCK 5/16 NC
9	2	608126	PIN, BLADE, DRL 2.04	24	2	1045655	NUT, HFN 5/16 NC, LOCK, GR F
10	2	57099	BLD, .50 X 4.00 X 19.00 CCW	25	3	1045628	NUT, HFN 3/8 NC, LOCK, GR F
11	2	32604	BLADE PIN LOCK CLIP SPEC	26	1	1045624	NUT, HFN 1/2 NC, LOCK, GR F
12	1	632366	PIN, 1.00 X 4.31, DRL	27	8	19025	NUT, HFN 5/8 NC, LOCK, GR F
13	1	1003828	MANUAL TUBE				
14	1	1035093RP	SHIELD SUPPORT BRACKET				
15	1	1035094RP	SHIELD SUPPORT BRACKET FRONT				

40 Parts

MAN1405
(04/29/2026)

BW10.30 WING ASSEMBLY

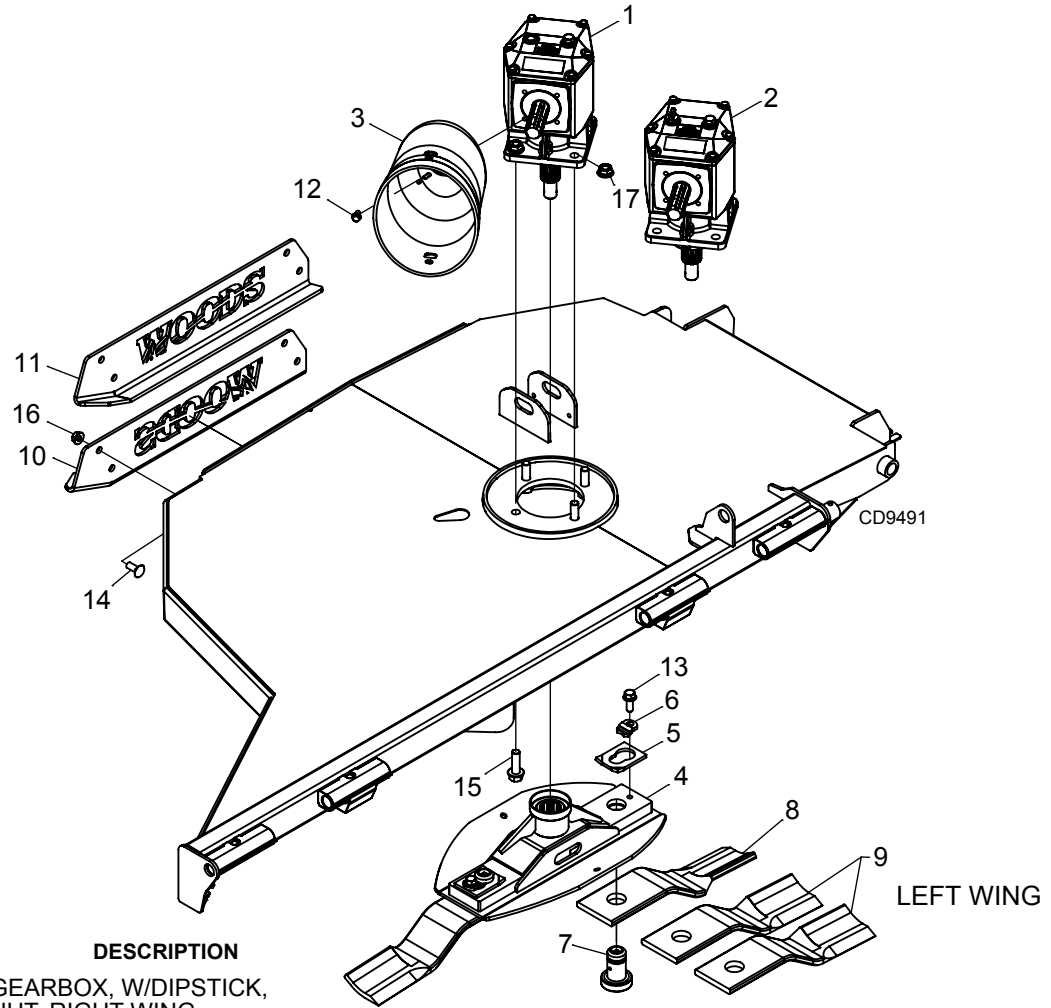

REF	QTY	PART	DESCRIPTION
1	1	617198RP	GEARBOX, W/DIPSTICK, NUT, RIGHT WING
2	1	651173RP	GEARBOX, W/DIPSTICK, NUT, LEFT WING
3	1	1002048	CLUTCH SHIELD 100&143 MM BC
4	1	651168RP	CROSSBAR
5	2	32603	KEYHOLE PLATE SPECIAL
6	2	32604	BLADE PIN LOCK CLIP SPEC
7	2	608126	PIN, BLADE, DRL 2.04
8	2	632953	BLADE, .50 X 4.0 X 14.0 CCW, 3.0
9	2	632954	BLADE, .50 X 4.0 X 14.0 CW, 3.0
10	1	645718RP	SKID, RIGHT
11	1	645719RP	SKID, LEFT
NS	1	**657221	DECAL, MODEL, BW10.30 MET BLACK
NS	2	**657233	DECAL, MDL, BAT IN BLACK, SMALL
NS	1	**657211	DECAL, MODEL, WOODS 80TH ANNIVERSARY
NS	2	651087	DECAL, MDL, BATWING, SMALL
NS	1	651089	DECAL, MDL, BW10.30

OBTAIN LOCALLY:

REF	QTY	PART	DESCRIPTION
12	4	1041071	BOLT, HEX FLNG M8 X16 CL8.8, DRI-LOC
13	2	1031225	BOLT, HEX FLNG 1/2 NC X 1.25 GR5
14	4	2615	BOLT CRG 1/2 NC X 1-1/4 GR5
15	4	1038890	HFS 5/8 NC X 2 GR8
16	4	1045624	NUT, HFN 1/2 NC, LOCK, GR F
17	4	19025	NUT, HFN 5/8 NC, LOCK, GR F

** ONLY USED ON 80TH ANNIVERSARY MODELS
NS NOT SHOWN

BW10.30 WHEEL ARM

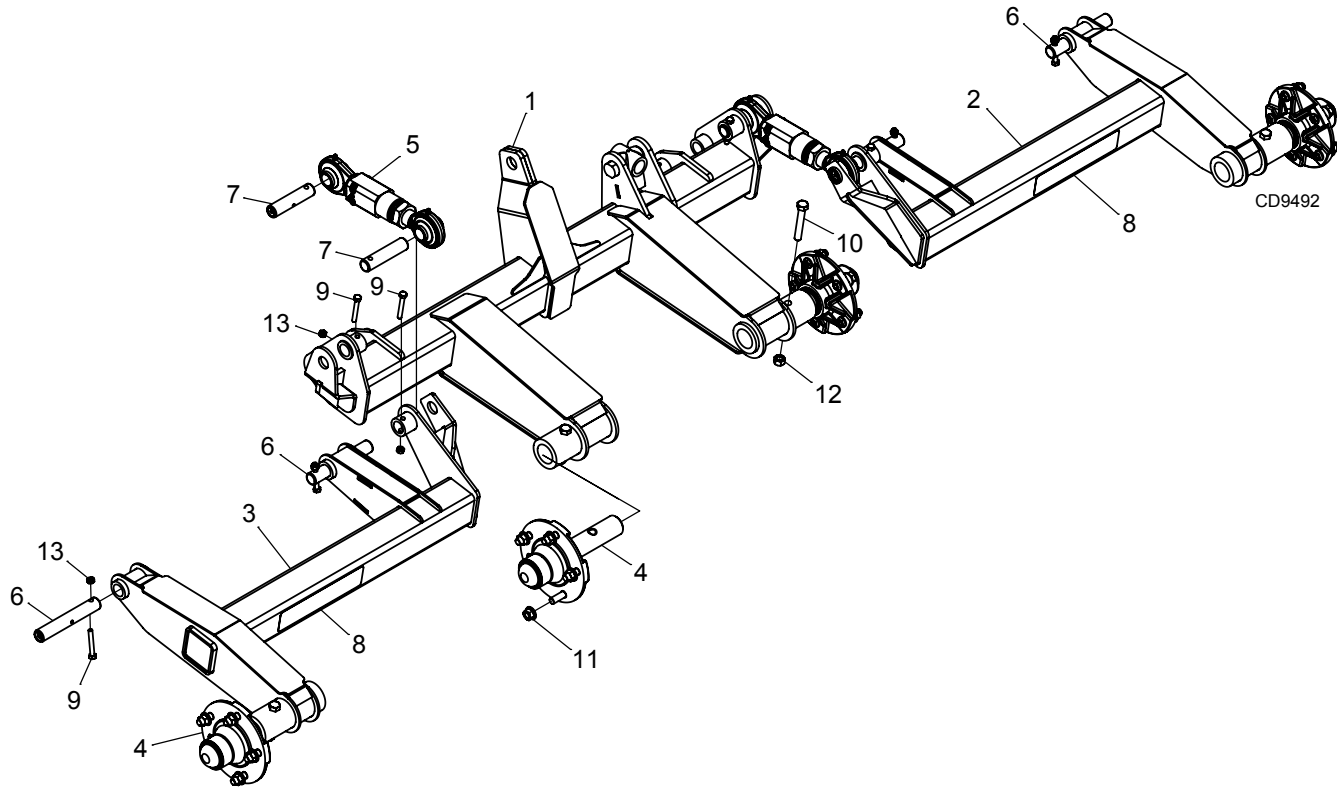

REF	QTY	PART	DESCRIPTION
1	1	651061RP	WHEEL ARM, CENTER
2	1	651062RP	WHEEL ARM, RIGHT
3	1	651063RP	WHEEL ARM, LEFT
4	4	1017050	WHEEL, HUB, 5 BOLT
5	2	1039950	ADJUSTABLE LINK, TRUNNION
6	4	632360	PIN, 1.00 X 6.31, DRL
7	4	632366	PIN, 1.00 X 4.31, DRL
8	2	57123	DECAL, REFLECTOR RED 2.0 X 9.0

OBTAIN LOCALLY:

REF	QTY	PART	DESCRIPTION
9	8	7164	HHCS 5/16 NC X 2-1/4 GR5
10	4	14069	HHCS 1/2 NC X 3-1/4
11	20	640406	NUT, 1/2-20 UNF FLANGE
12	4	765	NUT LOCK 1/2 NC ZP
13	8	6778	NUT LOCK 5/16 NC

42 Parts

MAN1405
(04/29/2026)

HOSE SUPPORT, SKIDS & MISCELLANEOUS

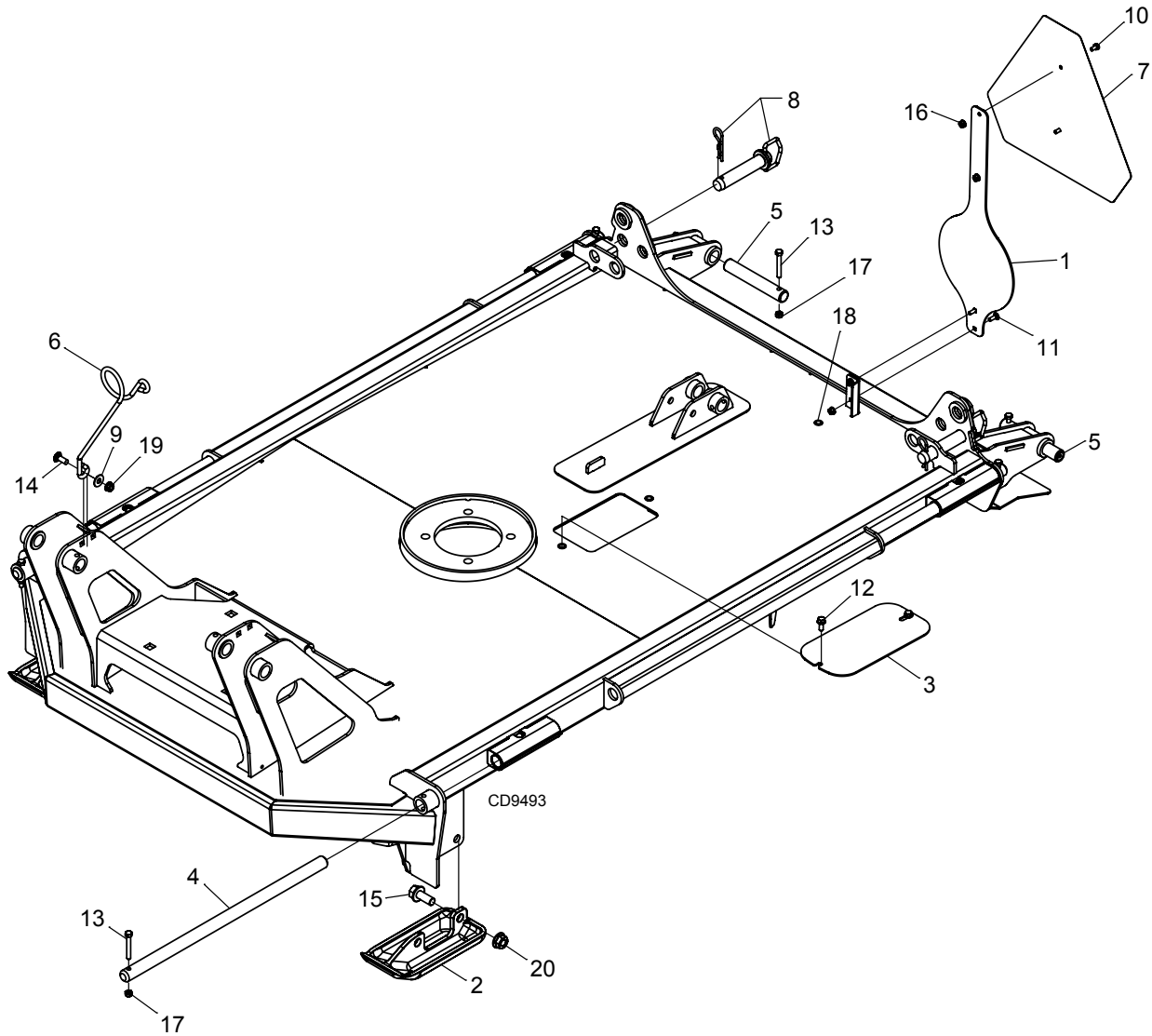

REF	QTY	PART	DESCRIPTION
1	1	632371RP	SMV BRACKET
2	2	639701RP	SKID SHOE
3	1	651083RP	DECK COVER PLATE
4	4	645690	PIN, HINGE 1.000 X 22.531
5	2	632360	PIN, 1.00 X 6.31, DRL
6	1	3443	HYD HOSE HOLDER
7	1	24611	SIGN (SMV) SLOW MOVING VEHICLE
8	2	S071051C0	PIN, 1 X 4-1/4 IN SWIV HITCH W/ CL

OBTAIN LOCALLY:

REF	QTY	PART	DESCRIPTION
9	1	565	WASHER, FLAT 3/8
10	2	5337	HHCS 1/4 NC X 1/2 GR5
11	2	21937	BOLT CRG 1/4 NC X 3/4
12	2	71851	BOLT, HEX FLNG 5/16 NC X .75 GR5
13	6	7164	HHCS 5/16 NC X 2-1/4 GR5
14	1	6697	BOLT CRG 3/8 NC X 1 GR5 ZP
15	4	603843	BOLT, HEX FLNG 5/8 NC X 1.50 GR8
16	4	62521	NUT LOCK 1/4 NC FLANGE
17	6	6778	NUT LOCK 5/16 NC
18	3	1045033	NUT, 5/16-18 UNC BLIND HOLE, HEX
19	1	1045628	NUT, HFN 3/8 NC, LOCK, GR F
20	4	19025	NUT, HFN 5/8 NC, LOCK, GR F

TONGUE ASSEMBLY

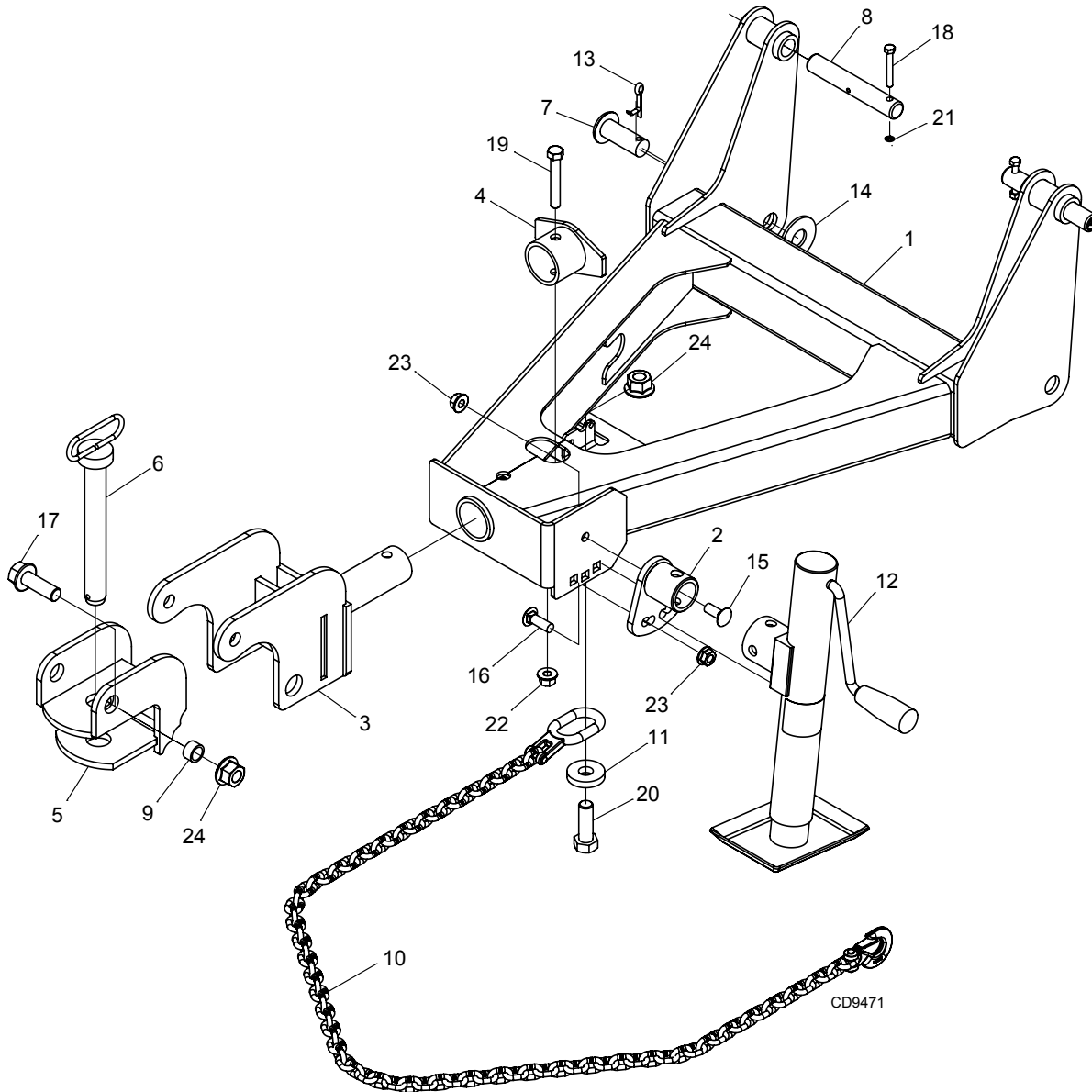

REF	QTY	PART	DESCRIPTION
1	1	642718RP	TONGUE WELDMENT
2	1	632840RP	JACK MOUNT WELDMENT
3	1	645644RP	HITCH WELDMENT
4	1	645643RP	HITCH ANGLE WELDMENT
5	1	645640RP	CLEVIS WELDMENT, CAT 2
6	1	S70056200	PIN, 1-1/8 X 8-1/2 IN RED HEAD HITCH
7	1	46605	PIN CLV 1.00 X 2.26
8	2	632360	PIN, 1.00 X 6.31, DRL
9	2	13087	SLV 3/4 X 1 X 9/16 HT
10	1	19407	ASY, SAFETY CHAIN, 10,000 LB
11	1	W8424	WSHR 3/4ID 2OD 3/8THICK
12	1	23790C	JACK, PARKING SWIVEL 1200LBS CERTIFIED

OBTAIN LOCALLY:

REF	QTY	PART	DESCRIPTION
13	1	6185	1/4 X 2-1/4 COTTER PIN
14	1	1863	WSHR 1" SAE
15	1	2615	BOLT CRG 1/2 NC X 1-1/4 GR5
16	1	29893	BOLT CRG 1/2 NC X 1-1/2 HT
17	2	603845	BOLT, HEX FLNG 3/4 NC X 2.25 GR5
18	2	7164	HHCS 5/16 NC X 2-1/4 GR5
19	1	14069	HHCS 1/2 NC X 3-1/4
20	1	13759	HHCS 3/4 NC X 2-1/4 GR5 ZP
21	2	6778	NUT LOCK 5/16 NC
22	1	11900	NUT, HFN 1/2 NC, LOCK, GR G
23	2	1045624	NUT, HFN 1/2 NC, LOCK, GR F
24	3	W302207	NUT, HFN 3/4 NC, LOCK, GR G

44 Parts

MAN1405
(04/29/2026)

SMARTLIFT™ CV LIFT ASSIST AND HOSE HOLDER (OPTIONAL)

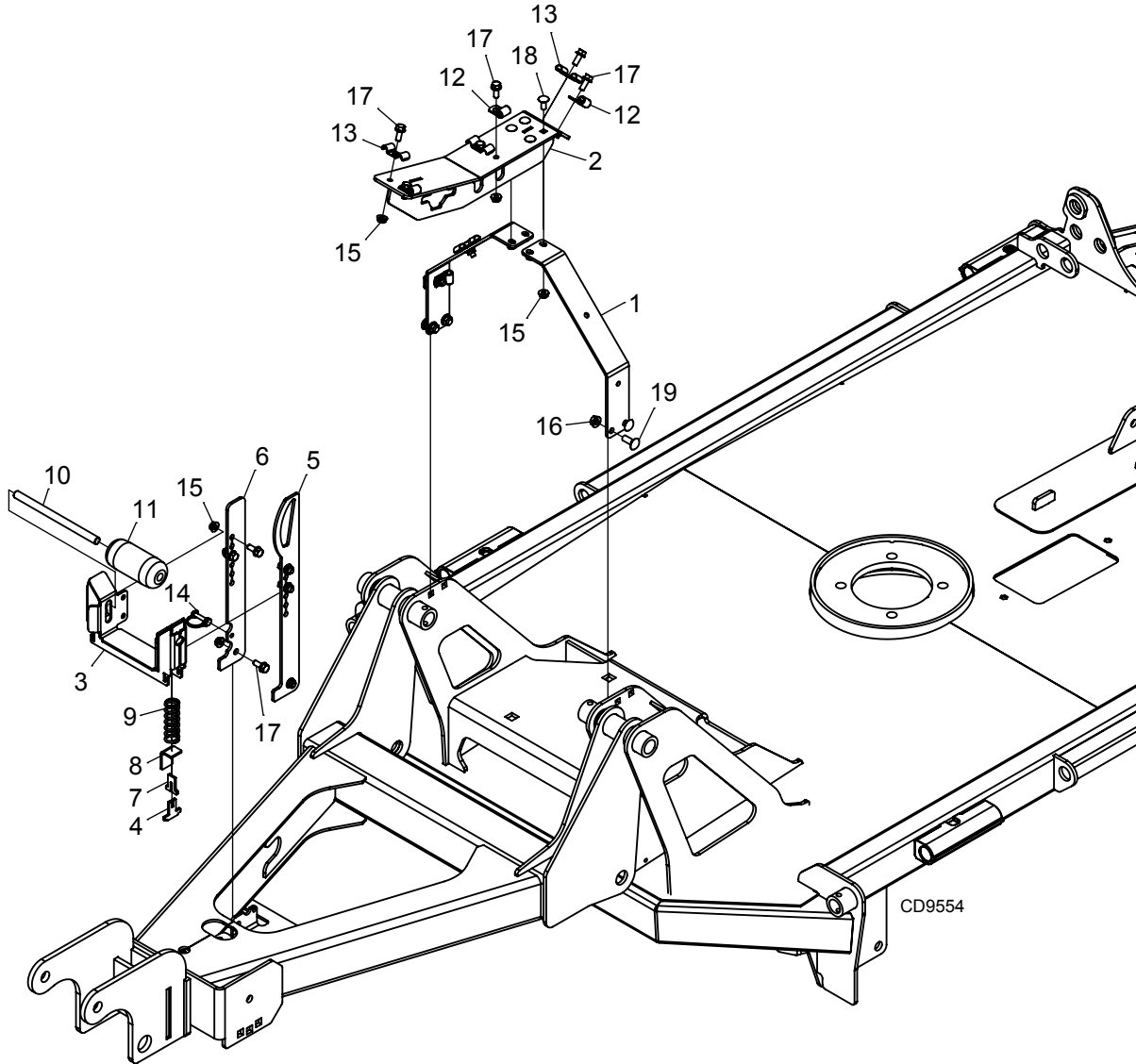

REF	QTY	PART	DESCRIPTION
A	1	651215	KIT, EASY CONNECT
1	2	645735RP	HOSE HOLDER UPRIGHT
2	1	645739RP	HOSE HOLDER BRACKET
3	1	1044930RP	SPRING LIFT WELDMENT
4	2	1045028RP	LINK, SPRING T
5	1	645634RP	CV LIFT ARM W/HANDLE
6	1	645635RP	CV LIFT ARM
7	2	1045027RP	LINK, SPRING
8	2	1045029RP	ANGLE, SPRING
9	2	1045026	SPRING, 1.0 X 3.0 - 65LB
10	1	1045030	PIN, .50 X 7.63
11	1	1029865	ROLLER 2 X 4.38
12	4	640361	LOOP CLAMP, .38 GALV STEEL, VINYL
13	5	480265	FEEDLINE CLAMP 3/8
14	1	613811	LOCK PIN, 1/4 X 1.0 RND

OBTAIN LOCALLY:

REF	QTY	PART	DESCRIPTION
15	18	1045655	NUT, HFN 5/16 NC, LOCK, GR F
16	4	1045628	NUT, HFN 3/8 NC, LOCK, GR F
17	14	71851	BOLT, HEX FLNG 5/16 NC X .75 GR5
18	4	51248	BOLT CRG 5/16 X 3/4 GR5 ZP
19	4	6697	BOLT CRG 3/8 NC X 1 GR5 ZP

MAN1405
(04/29/2026)

Parts 45

BW10.30 WING & CENTER GEARBOX ASSEMBLY

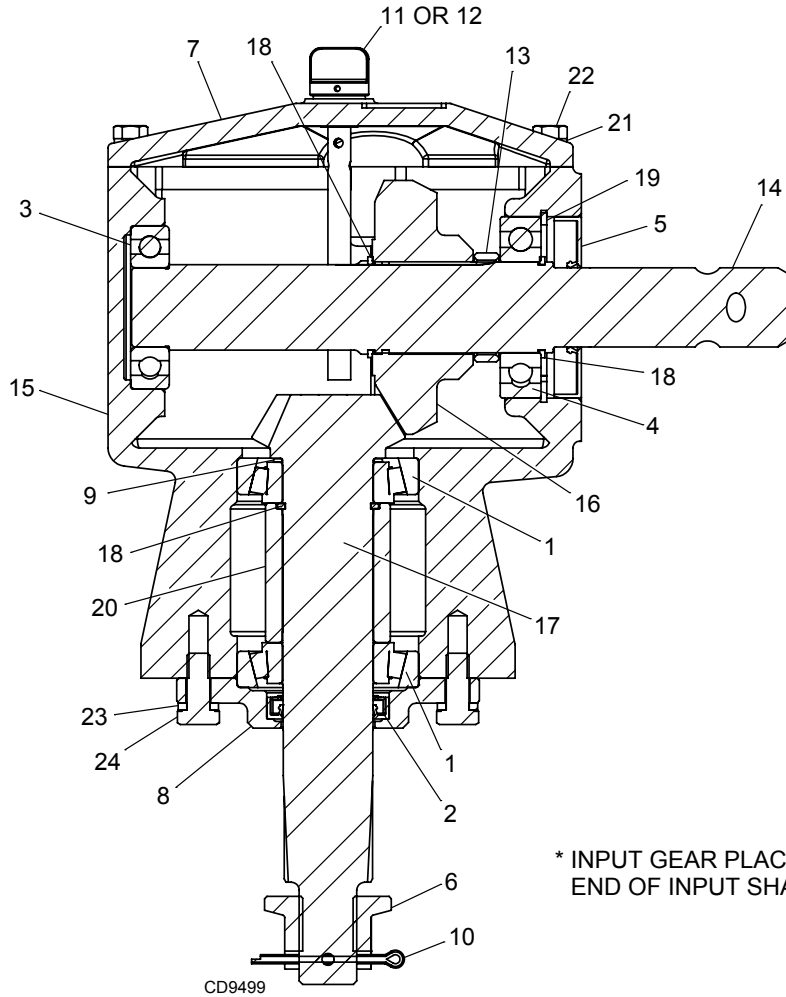

* INPUT GEAR PLACED ON OPPOSITE
END OF INPUT SHAFT FOR RIGHT WING

REF	PART	QTY	DESCRIPTION	REF	PART	QTY	DESCRIPTION
A	617198RP	1	COMPLETE GEARBOX, LEFT WING	13	NSS	1	GEAR SPACER
B	651173RP	1	COMPLETE GEARBOX, RIGHT WING	14	NSS	1	INPUT SHAFT
C	617198RP	1	COMPLETE GEARBOX, CENTER DECK	15	NSS	1	HOUSING
1	57478	2	BEARING CUP & CONE	16	NSS	1	INPUT GEAR
2	614308	1	SEAL, NAK, 39.7 X 54.1 X 9.5	17	NSS	1	OUTPUT SHAFT AND PINION
3	1018325	1	BEARING, BALL	18	NSS	3	RETAINING RING
4	1018326	1	BEARING, BALL	19	NSS	1	RETAINING RING
5	1018327	1	SEAL, OIL 35 X 80 X 12	20	NSS	1	OUTPUT BEARING SPACER
6	1018331	1	NUT, SLOTTED FLANGE 1-14	21	NSS	6	LOCK WASHER, M8
7	1019632	1	INSPECTION COVER	22	NSS	6	M8 X 1.5 X 25 CAP SCREW
8	1038357	1	OUTPUT, CAP	23	NSS	4	LOCK WASHER, M10
9	1032963	1	SHIM KIT	24	NSS	4	M10 X 1.5 X 25 CAP SCREW
10	1035015	1	5/32X2-1/2 COTTER PIN				
11	614309	1	DIPSTICK, SD 31, 125.5				
12	1011780RP	1	VENT PLUG AND WASHER				

46 Parts

MAN1405
(04/29/2026)

BW10.30 SPLITTER GEARBOX ASSEMBLY

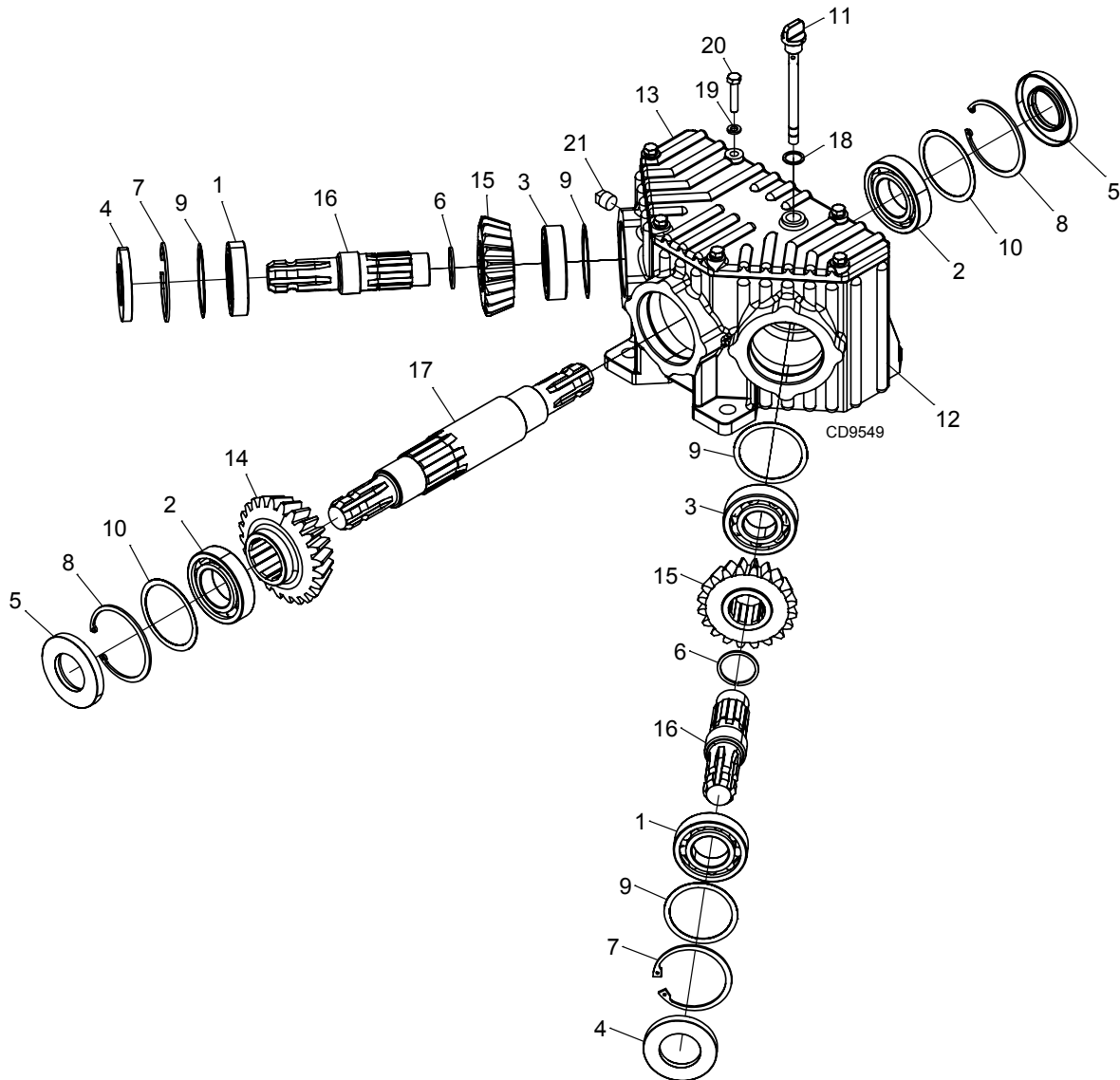

REF	PART	QTY	DESCRIPTION
A	651172	1	COMPLETE SPLITTER GEARBOX
1	20891	2	BALL BEARING 208
2	1034979	2	BALL BEARING 209
3	W39414	2	BALL BEARING 307
4	1005304	2	OIL SEAL Ø45MM X Ø80MM X 10MM
5	57318	2	OIL SEAL Ø45MM X Ø85MM X 10MM
6	W20895	2	40MM X 1.75MM RETAINING RING
7	W20895	2	Ø80MM BORE RETAINING RING
8	57320	2	Ø85MM BORE RETAINING RING
9	1005306	4	SHIM - VARIOUS
10	1005307	2	SHIM - VARIOUS
11	651202	1	M18 X 1.5 DIP STICK TS FF BREATHER ASSY.
12	NSS	1	HOUSING

REF	PART	QTY	DESCRIPTION
13	NSS	1	INSPECTION COVER CAP
14	NSS	1	27 TOOTH GEAR
15	NSS	2	20 TOOTH GEAR
16	NSS	2	1 3/8"-6 OUTPUT SHAFT
17	NSS	1	1 3/8"-6 THRU SHAFT
	NSS		NOT SERVICED SEPARATELY

OBTAIN LOCALLY:

REF	PART	QTY	DESCRIPTION
18	----	1	SEALING WASHER 23MM X 18MM X 1.5MM
19	----	6	M8 LOCK WASHER
20	----	6	M8 X 1.25 X 40 HEX HEAD CAP SCREW
21	----	3	M18 X 1.5 HEX HEAD PLUG

BW10.30 CENTER DECK DRIVE ASSEMBLY

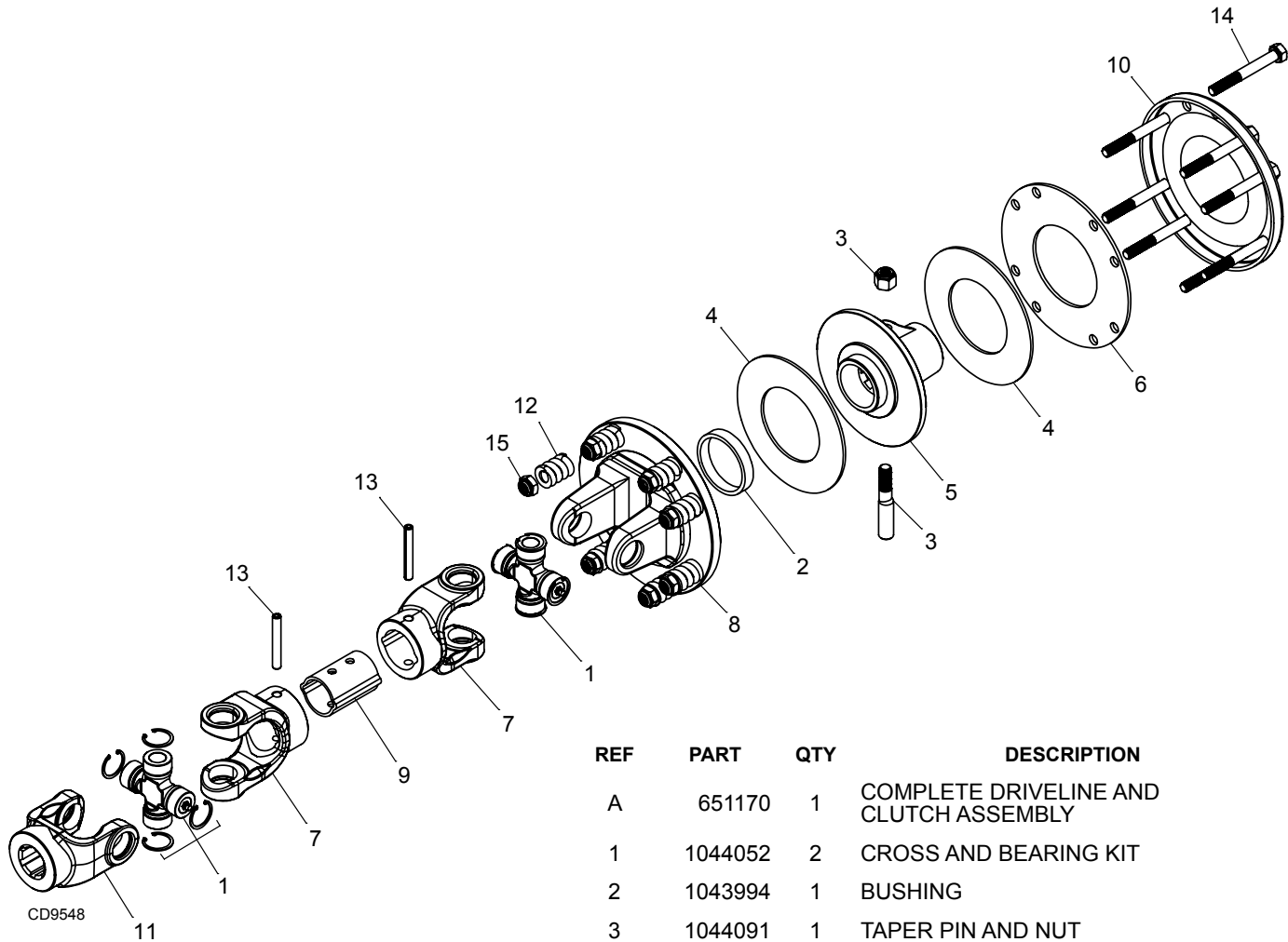

REF	PART	QTY	DESCRIPTION
A	651170	1	COMPLETE DRIVELINE AND CLUTCH ASSEMBLY
1	1044052	2	CROSS AND BEARING KIT
2	1043994	1	BUSHING
3	1044091	1	TAPER PIN AND NUT
4	1044083	2	FRICION DISC
5	NSS	1	FLANGED YOKE
6	NSS	1	INTERNAL DISC
7	NSS	2	INTERNAL YOKE
8	NSS	1	FLANGED YOKE, SPRING
9	NSS	1	OUTER TUBE
10	NSS	1	PRESSURE PLATE
11	NSS	1	SPLINED YOKE
12	NSS	8	SPRING
	NSS		NOT SERVICED SEPARATELY

OBTAIN LOCALLY:

REF	PART	QTY	DESCRIPTION
13	----	2	8 MM X 80 MM LONG SPRING PIN
14	----	8	M10 X 1.5 X 85 MM HHCS
15	----	8	M10 X 1.5 LOCK NUT

48 Parts

MAN1405
(04/29/2026)

BW10.30 WING DRIVE ASSEMBLY

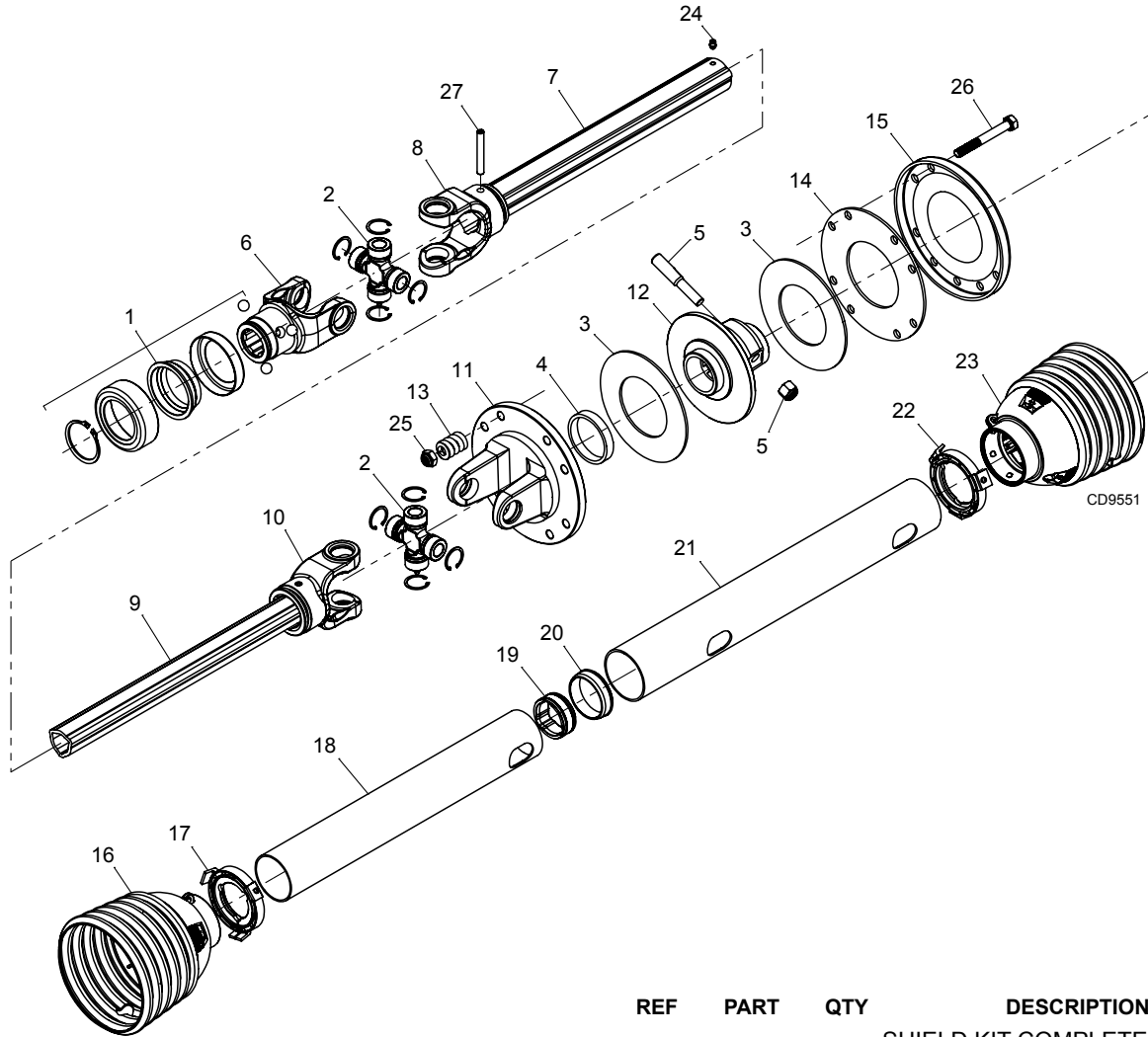

REF	PART	QTY	DESCRIPTION
A	651171	1	COMPLETE DRIVELINE AND CLUTCH ASY
1	1044050	1	KIT, LOCK COLLAR REPAIR
2	1044052	2	CROSS AND BEARING KIT
3	1044083	2	FRICTION DISC
4	1043994	1	BUSHING
5	1044091	1	TAPERED PIN AND NUT
6	NSS	1	SPLINED YOKE
7	NSS	1	OUTER TUBE
8	NSS	1	OUTER TUBE YOKE
9	NSS	1	INNER TUBE
10	NSS	1	INNER YOKE
11	NSS	1	FLANGED YOKE, SPRING
12	NSS	1	FLANGED YOKE
13	NSS	1	SPRING
14	NSS	1	INTERNAL DISC
15	NSS	1	PRESSURE PLATE

REF	PART	QTY	DESCRIPTION
B	651221	1	SHIELD KIT COMPLETE (INCLUDES 16-23)
16	NSS	1	PLASTIC COVER
17	NSS	1	WHITE BEARING
18	NSS	1	INNER PLASTIC TUBE
19	NSS	1	INNER SUPPORT BEARING
20	NSS	1	OUTER SUPPORT BEARING
21	NSS	1	OUTER PLASTIC TUBE
22	NSS	1	WHITE BEARING
23	NSS	1	PLASTIC COVER

OBTAIN LOCALLY:

REF	PART	QTY	DESCRIPTION
24	----	1	GREASE FITTING, M6X1.0
25	----	1	M10 X 1.5 LOCK NUT
26	----	1	M10 X 1.5 X 85 MM HHCS
27	----	2	8 MM X 85 MM LONG SPRING PIN

NSS NOT SERVICED SEPARATELY

CV DRIVE ASSEMBLY

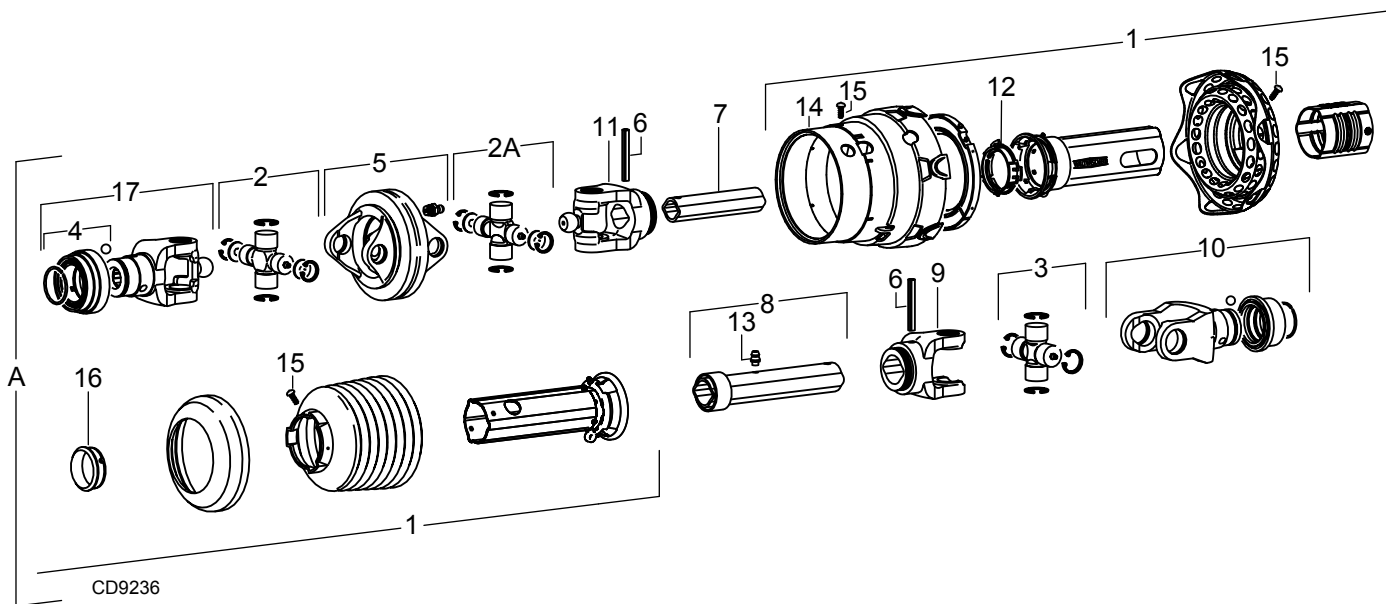

REF	PART	QTY	DESCRIPTION
A	651210	1	Complete CV drive
1	651217	1	Complete guard kit
2	651218	1	Cross and bearing kit
2A	651222	1	Cross and bearing kit
3	651219	1	Cross and bearing kit
4	632554	1	Slide collar repair kit
5	NSS	1	Double yoke
6	NSS	2	Spring pin
7	NSS	1	Inner profile
8	NSS	1	Outer profile
9	NSS	1	Inboard yoke
10	NSS	1	Yoke, 1-3/8, 6 spline
11	NSS	1	Inner yoke
12	NSS	1	Bearing ring
13	NSS	1	Grease fitting
14	NSS	1	Cone and bearing assembly
15	NSS	10	Screw
16	NSS	1	Support bearing
17	NSS	1	Yoke, 1-3/8, 6 spline
	NSS		Not Serviced Separately

50 Parts

MAN1405
(04/29/2026)

LIGHTS AND WIRING (OPTIONAL)

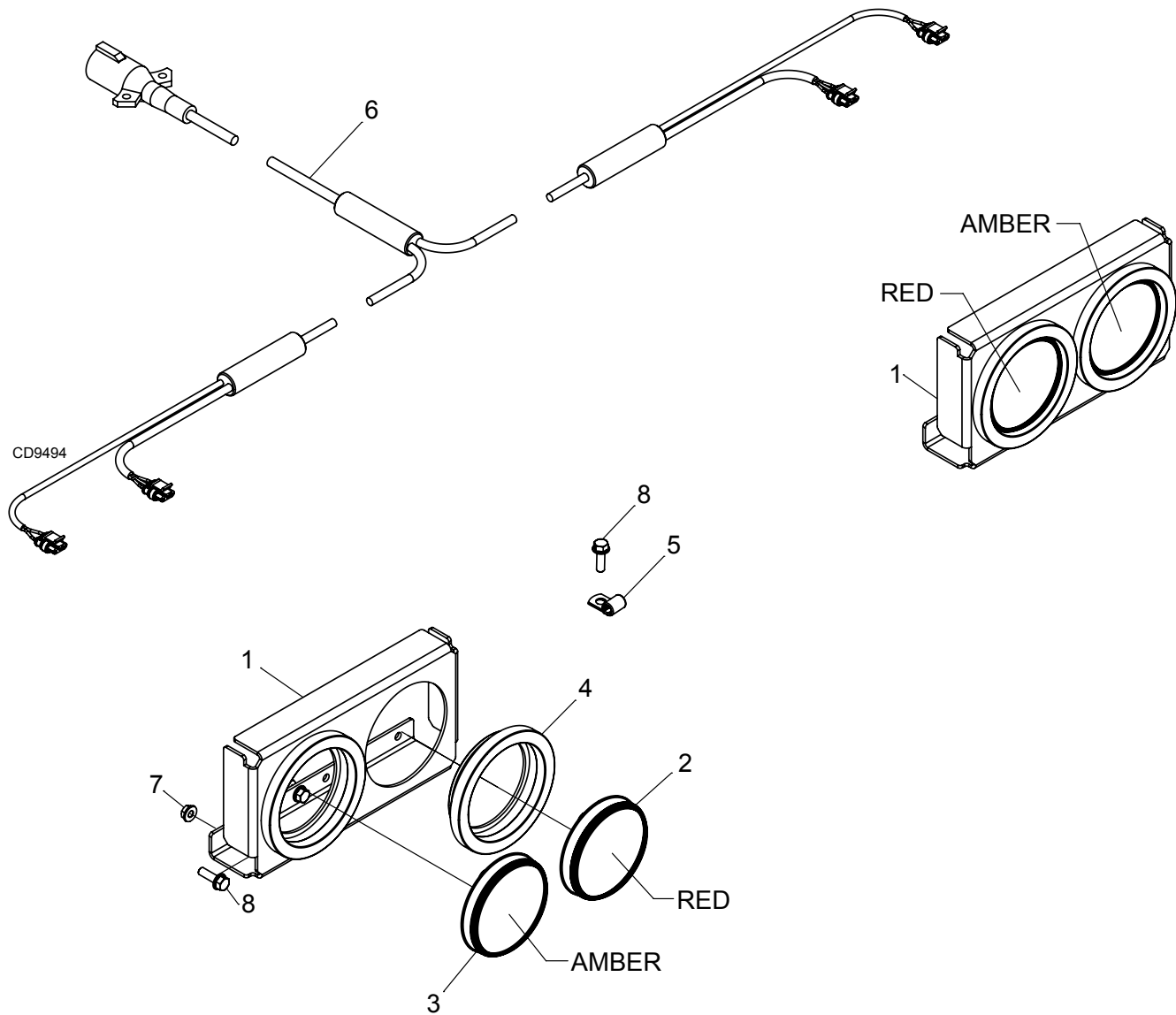

REF	QTY	PART	DESCRIPTION	OBTAIN LOCALLY:			
				REF	QTY	PART	DESCRIPTION
A	1	651216	KIT, LIGHTS AND HARNESS	7	4	1045655	NUT, HFN 5/16 NC, LOCK, GR F
1	2	645689RP	BRACKET, LIGHTS	8	5	71632	BOLT, HEX FLNG 5/16 NC X 1.00, SRTD
2	2	632805	LAMP, 4 IN ROUND RED STOP - TAIL				
3	2	632806	LAMP, 4 IN ROUND AMBER TURN				
4	4	632807	GROMMET, 4 IN ROUND LAMP				
5	1	640361	LOOP CLAMP, .38 GALV STEEL, VINYL				
6	1	640367	HARNESS, BW12 LIGHTING				

CHAIN SHIELDING

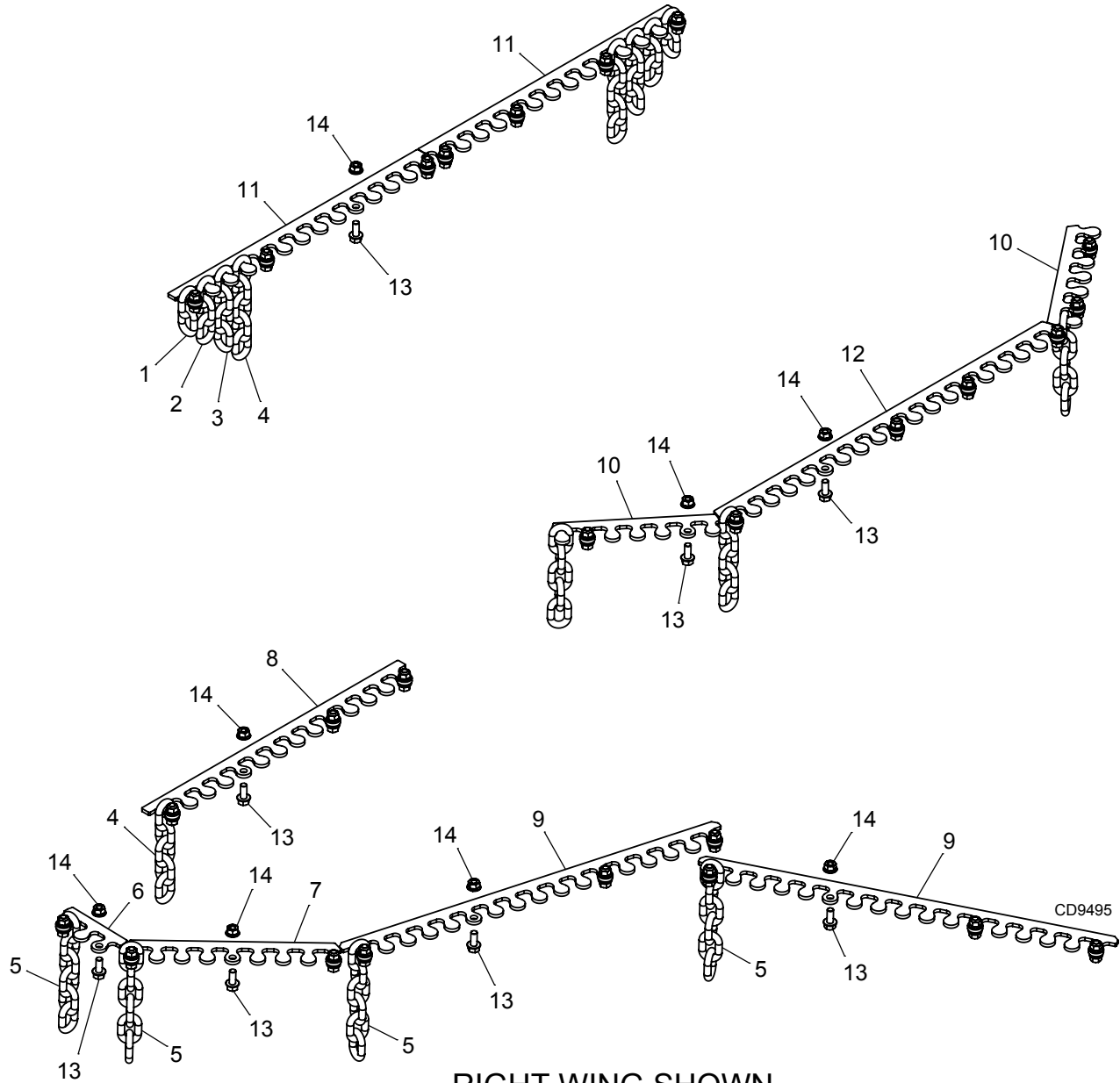

RIGHT WING SHOWN

REF	QTY	PART	DESCRIPTION
1	2	1041055	5/16 CHAIN 2 LINK
2	2	1041054	5/16 CHAIN 3 LINK
3	2	4069	5/16 CHAIN 4 LINK
4	83	3994	5/16 CHAIN 5 LINK
5	92	5498	5/16 CHAIN 6 LINK
6	2	651148RP	WING OUTER LINK, 3
7	2	651147RP	WING ANGLE LINK, 9
8	2	651144RP	WING REAR LINK, 14
9	4	651145RP	WING FRONT LINK, 17
10	2	651151RP	CENTER ANGLE LINK, 7
11	2	651149RP	CENTER REAR LINK, 15
12	1	651150RP	CENTER FRONT LINK, 19

OBTAIN LOCALLY:

13	51	654068	BOLT, HEX FLNG 5/16 NC X .75 GR8
14	51	14139	NUT, HFN 5/16 NC, LOCK, GR G

52 Parts

MAN1405
(04/29/2026)

CYLINDER AND HOSE ASSEMBLY

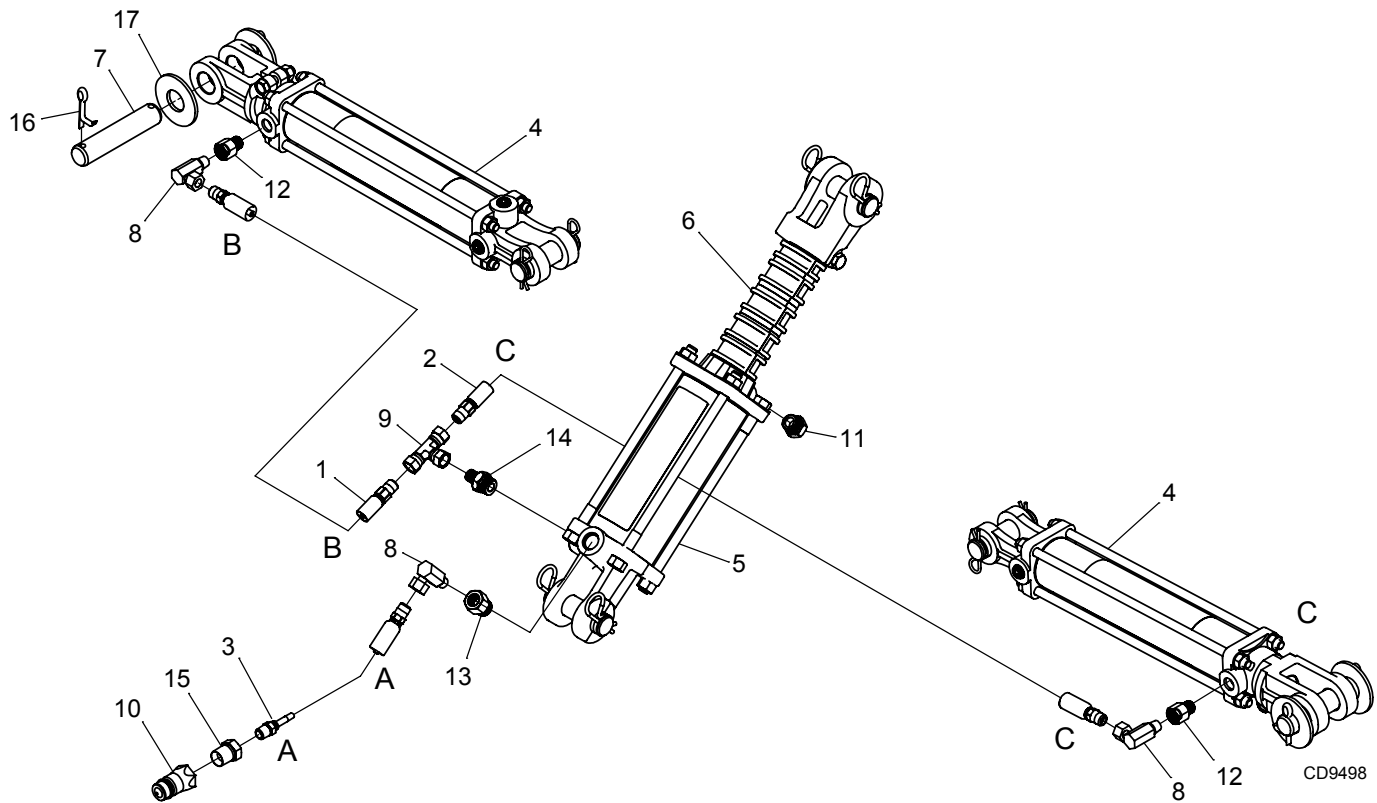

REF	QTY	PART	DESCRIPTION
1	1	8107	1/4 1 WIRE X 36 HYD HOSE
2	1	28522	HOSE, .25ID X .25NPT X 54
3	1	645808	HOSE, .25ID X 174 - .25NPTM X .25NPTM
4	2	597264	CYLINDER, 2.0 X 1.13 X 10.0 SAE6
5	1	597266	CYLINDER, 3.0 X 1.25 X 6.0 SAE8
6	1	24098A	1-1/4CYL STRK CNTRL SET
7	2	8345	PIN HDLS 1.00 X 4.08
8	3	10290	1/4 X 1/4 90 EL 1/16 RSTR
9	1	31239	FITTING, 1/4 F SWIVEL UNION TEE
10	1	66511	CPLR MALE ISO 1/2 NPT
11	1	609608	BRTHR, VENT SAE 8 ORING
12	2	651174	ADAPTER, 1/4 NPTF FEMALE TO 9/16 ORBM
13	1	651176	ADAPTER, 1/4 NPTF FEMALE TO 3/4 ORBM
14	1	651195	ADAPTER, 1/4 NPTF MALE TO 3/4 ORBM
15	1	W11893	ADAPTER 1/4 NPTF 1/2 NPTM

OBTAIN LOCALLY:

REF	QTY	PART	DESCRIPTION
16	4	1285	1/4 X 1-1/2 COTTER PIN
17	4	832	WSHR 1 STD FLAT

HYDRAULIC CYLINDERS

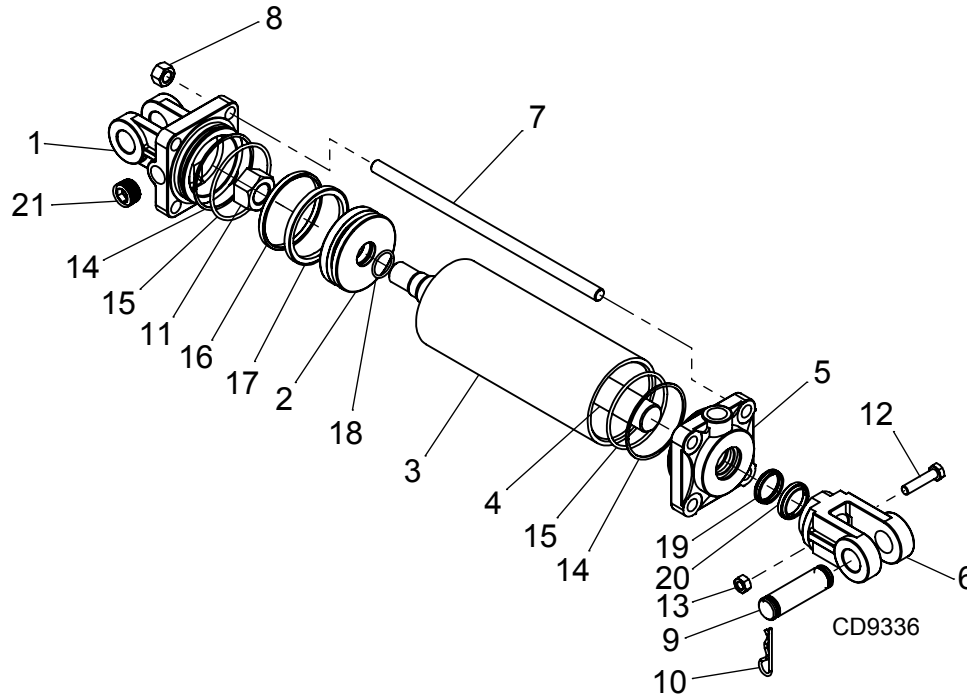

REF	2.0 x 10.0 WING	3.0 x 6.0 LIFT	QTY	DESCRIPTION
1	NSS	NSS	1	CLEVIS, BASE
2	NSS	NSS	1	PISTON
3	NSS	NSS	1	BARREL
4	NSS	NSS	1	ROD
5	NSS	NSS	1	GUIDE
6	NSS	NSS	1	CLEVIS, ROD
7	NSS	NSS	1	TIE ROD
8	*	*	8	NUT, TIE ROD
9	NSS	NSS	1	PIN, 1.00
10	*	*	4	HAIR PIN
11	*	*	1	NUT, PISTON
12	*	*	1	BOLT
13	*	*	1	NUT, CLAMP
14	NSS	NSS	2	BACKUP RING, TUBE
15	NSS	NSS	2	O-RING, TUBE
16	-	NSS	1	WEAR RING
17	NSS	NSS	1	PISTON SEAL
18	NSS	NSS	1	O-RING, PISTON
19	NSS	NSS	1	ROD SEAL
20	NSS	NSS	1	WIPER RING
21	*	*	1	PLUG, 1/2 NPT
22	651203	651204		SEAL KIT, INCLUDES ITEMS 14 - 20
23	-	651205	1	3 X 6 HYDRAULIC CYLINDER W/ BREATHER
24	597264	-	2	2 X 10 HYDRAULIC CYLINDER, COMPLETE
		*		OBTAIN LOCALLY
		NSS		NOT SOLD SEPARATELY

54 Parts

MAN1405
(04/29/2026)

WHEEL AND TIRE ASSEMBLIES

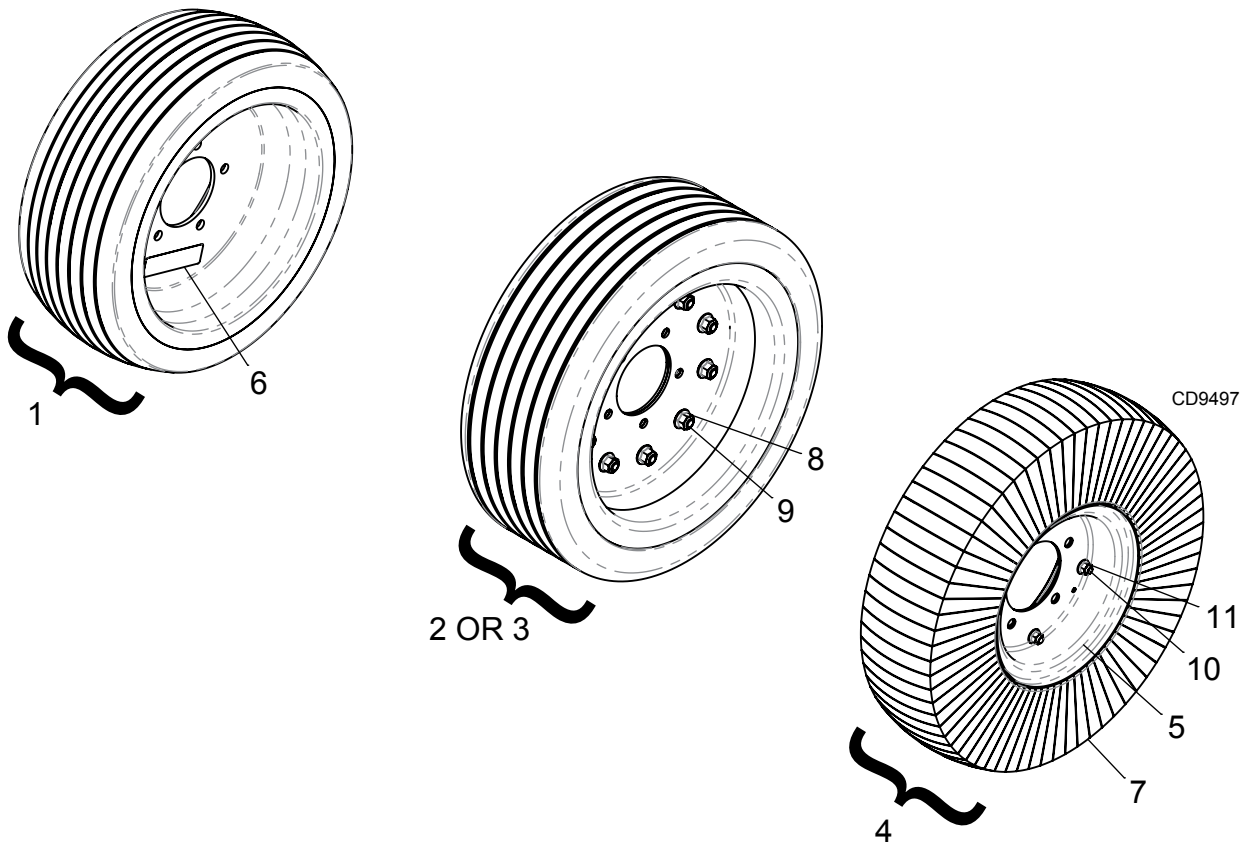

REF	QTY	PART	DESCRIPTION
1	1	609309	WHEEL ASY, USED AIRCRAFT, 20.5 X 6.75-10
2	1	645682	WHEEL ASY, ROUGH DUTY AG 21X7-12 16PR
3	1	645682F	WHEEL ASY, FOAM FILLED ROUGH DUTY AG 21X7-12 16PR
4	1	1017040	WHEEL ASY, LAMINATED, 21 OD
5	2	1017042	RIM HALF 6 X 9 TIRE 5 BLT
6	1	1006348	DCL, WRNG, WHEEL RIM EXPLOSION
7	1	7429	6 X 9 LAMINATED TIRE

OBTAIN LOCALLY:

REF	QTY	PART	DESCRIPTION
8	10	11900	NUT, HFN 1/2 NC, LOCK, GR G
9	10	1045070	SCREW, HFS, 1/2 NC X 1.0 GR5
10	5	*	BOLT, HEX FLNG 3/8 NC X 1.00 GR5 SRTD
11	5	14350	NUT, HFN 3/8 NC, LOCK, GR G

* STANDARD HARDWARE, OBTAIN LOCALLY

ATTITUDE ROD

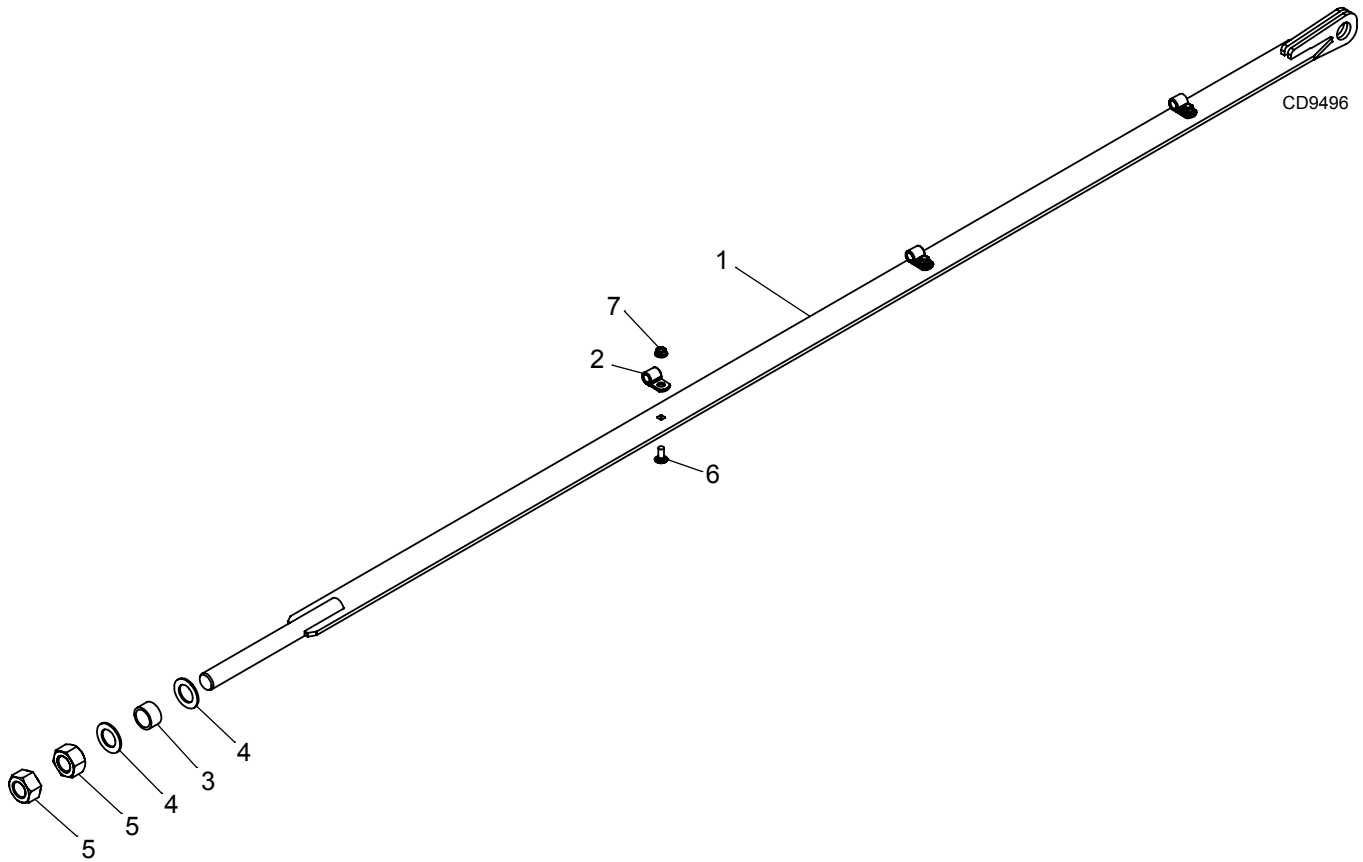

REF	QTY	PART	DESCRIPTION
1	1	651154RP	ATTITUDE ROD WELDMENT
2	3	78059	CLAMP .50 DIA STEEL CUSHION
3	1	33647	SLV, 1.313 X 1.049 X .75

OBTAIN LOCALLY:

REF	QTY	PART	DESCRIPTION
4	2	1863	WASHER, FLAT, 1 SAE ZP
5	2	3132	NUT HEX 1 NC ZP
6	3	16148	BOLT CRG 5/16NC X 3/4 ZP
7	3	1045655	NUT, HFN 5/16 NC, LOCK, GR F

56 Parts

MAN1405
(04/29/2026)

BOLT TORQUE CHART

Always tighten hardware to these values unless a different torque value or tightening procedure is listed for a specific application.

Fasteners must always be replaced with the same grade as specified in the manual parts list.

Always use the proper tool for tightening hardware: SAE for SAE hardware and Metric for metric hardware. Make sure fastener threads are clean and you start thread engagement properly.

All torque values are given to specifications used on hardware defined by SAE J1701 MAR 99 & J1701M JUL 96.

SAE SERIES TORQUE CHART

SAE Bolt Head Identification

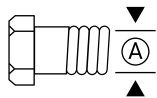

SAE Grade 2
(No Dashes)



SAE Grade 5
(3 Radial Dashes)



SAE Grade 8
(6 Radial Dashes)

Ⓐ	Diameter (Inches)	Wrench Size	Marking on Head					
			SAE 2		SAE 5		SAE 8	
			lbs-ft	N-m	lbs-ft	N-m	lbs-ft	N-m
1/4"	7/16"	6	8	10	13	14	18	
5/16"	1/2"	12	17	19	26	27	37	
3/8"	9/16"	23	31	35	47	49	67	
7/16"	5/8"	36	48	55	75	78	106	
1/2"	3/4"	55	75	85	115	120	163	
9/16"	13/16"	78	106	121	164	171	232	
5/8"	15/16"	110	149	170	230	240	325	
3/4"	1-1/8"	192	261	297	403	420	569	
7/8"	1-5/16"	306	416	474	642	669	907	
1"	1-1/2"	467	634	722	979	1020	1383	

TYPICAL WASHER INSTALLATIONS

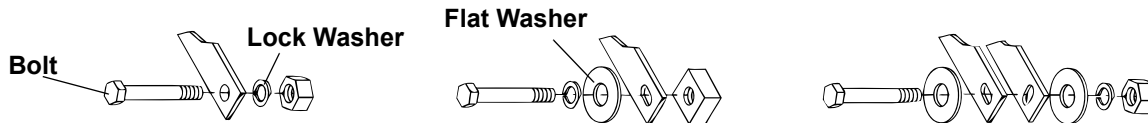

METRIC SERIES TORQUE CHART

Metric Bolt Head Identification

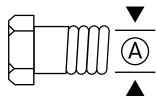

Metric
Grade 8.8



Metric
Grade 10.9

Ⓐ	Diameter & Thread Pitch (Millimeters)	Wrench Size	Marking on Head								Ⓐ
			Coarse Thread				Fine Thread				
			Metric 8.8		Metric 10.9		Metric 8.8		Metric 10.9		
N-m	lbs-ft	N-m	lbs-ft	N-m	lbs-ft	N-m	lbs-ft	Diameter & Thread Pitch (Millimeters)			
6 x 1.0	10 mm	8	6	11	8	8	6	11	8	6 x 1.0	
8 x 1.25	13 mm	20	15	27	20	21	16	29	22	8 x 1.0	
10 x 1.5	16 mm	39	29	54	40	41	30	57	42	10 x 1.25	
12 x 1.75	18 mm	68	50	94	70	75	55	103	76	12 x 1.25	
14 x 2.0	21 mm	109	80	151	111	118	87	163	120	14 x 1.5	
16 x 2.0	24 mm	169	125	234	173	181	133	250	184	16 x 1.5	
18 x 2.5	27 mm	234	172	323	239	263	194	363	268	18 x 1.5	
20 x 2.5	30 mm	330	244	457	337	367	270	507	374	20 x 1.5	
22 x 2.5	34 mm	451	332	623	460	495	365	684	505	22 x 1.5	
24 x 3.0	36 mm	571	421	790	583	623	459	861	635	24 x 2.0	
30 x 3.0	46 mm	1175	867	1626	1199	1258	928	1740	1283	30 x 2.0	

BOLT SIZE CHART

NOTICE: Chart shows bolt thread sizes and corresponding head (wrench) sizes for standard SAE and metric bolts.

SAE BOLT THREAD SIZES

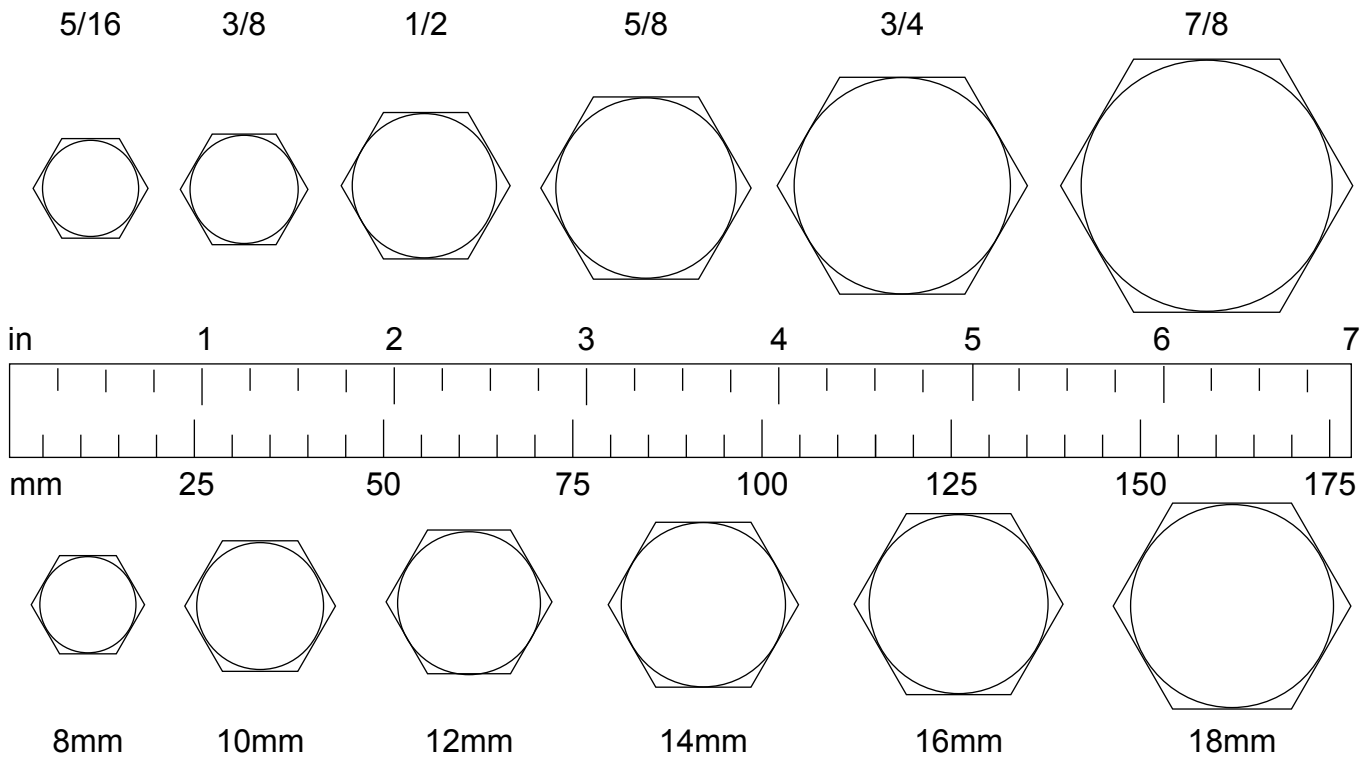

METRIC BOLT THREAD SIZES

ABBREVIATIONS

AG Agriculture	HT Heat-Treated	ORBM O-Ring Boss - Male
ASABE American Society of Agricultural & Biological Engineers (formerly ASAE)	JIC Joint Industry Council 37° Degree Flare	P Pitch
ASAE American Society of Agricultural Engineers	LH Left Hand	PBY Power-Beyond
ATF Automatic Transmission Fluid	LT Left	psi Pounds per Square Inch
BSPP British Standard Pipe Parallel	m Meter	PTO Power Take Off
BSPTM British Standard Pipe Tapered Male	mm Millimeter	QD Quick Disconnect
CV Constant Velocity	M Male	RH Right Hand
CCW Counter-Clockwise	MPa Mega Pascal	ROPS Roll-Over Protective Structure
CW Clockwise	N Newton	RPM Revolutions Per Minute
F Female	NC National Coarse	RT Right
FT Full Thread	NF National Fine	SAE Society of Automotive Engineers
GA Gauge	NPSM National Pipe Straight Mechanical	UNC Unified Coarse
GR (5, etc.) Grade (5, etc.)	NPT National Pipe Tapered	UNF Unified Fine
HHCS Hex Head Cap Screw	NPT SWF National Pipe Tapered Swivel Female	UNS Unified Special

INDEX

ADJUSTMENTS

- Cutting Height 16
- Slip Clutch 24

ASSEMBLY

- Dealer Set-Up Instructions 36

DEALER CHECKLIST

- Checklists
 - Delivery (Dealer's Responsibility) 38
 - Pre-Delivery (Dealer's Responsibility) 38

DEALER SERVICE

- Crossbar
 - Installation 33
 - Removal 33
- Gearbox Maintenance
 - Seal Installation 28
 - Seal Replacement 28
- Gearbox Repair
 - Disassembly 29
 - Removal 29
- Seal Repair
 - Horizontal Shaft 29
 - Reassemble 29
 - Reinstallaton 30
 - Vertical Shaft 29
- Splitter Gearbox Repair
 - Assembly 31
 - Check Gearbox for Leaks 32
 - Disassembly 31
 - Reinstallation 32
 - Removal from Cutter 31
- Universal Joint
 - Assembly 35
 - Disassembly 34
 - Repair 34

GENERAL

- Abbreviations 59
- Bolt Size Chart 59
- Bolt Torque Chart 58
- General Information 4
- Introduction 2
- Obtaining Replacement Manuals 2
- Product Registration 2
- Specifications 4
- Table of Contents 3

OPERATION

- Connecting Cutter to Tractor 15
 - Cutting Height Adjustment 17
 - CV Driveline Turning Limits 16
 - Hydraulic Connection 16
 - Interference Check 16
 - Leveling Tongue Clevis 15
 - Mechanical Connection 16
 - SmartLift™* Lift Assist System 16
- Cutter Operation 17
 - Mowing Tips 18
 - Shredding 18
- Pre-Operation Checklist (Owner's Responsibility) 20
- Storage 19
- Tractor Operation 17
- Transporting 18
 - Lock-Up 18
 - Center Section 19
 - Wing 18

OWNER SERVICE

- Adjusting Slip Clutch 22
- Blades
 - Installation 24
 - Removal 23
 - Sharpening 24
- Blocking Method 21
- Cleaning 26
- Lubrication
 - Driveline 23
 - Gearbox 23
 - Lubrication Points 22
 - Seasonal 23
- Servicing Tires 26, 35
- Shielding Repair 25
- Slip Clutch Adjustment 24
- Troubleshooting 27

PARTS

- Parts Index 39

SAFETY

- Blocking Method 21
- Checklists
 - Delivery Checklist (Dealer's Responsibility) 38
 - Pre-Delivery Checklist (Dealer's Responsibility) 38
 - Pre-Operation Checklist (Owner's Responsibility) 20
- Online Safety Video 5, 6
- Safety & Instructional Decals 12 - 14
- Safety Rules 7 - 11
- Safety Symbols Explained 2

PART NO.
MAN1405

WOODS®

2606 South Illinois Route 2
Post Office Box 1 000
Oregon, Illinois 61061 USA

800-319-6637 tel
800-399-6637 fax
woodsequipment.com



© 2026 Woods Equipment Company. All rights reserved. Woods® and the Woods logo are trademarks of Woods Equipment Company. All other trademarks, trade names, or service marks not owned by Woods Equipment Company that appear in this manual are the property of their respective companies or mark holders. Specifications subject to change without notice.